



SLOVENSKI STANDARD

SIST ISO 6237:1998

01-februar-1998

Adhezivni spoji les na les -- Določitev trdnosti spoja pri nategu

Adhesives -- Wood-to-wood adhesive bonds -- Determination of shear strength by tensile loading

Adhésifs -- Joints collés de bois à bois -- Détermination de la résistance au cisaillement par effort de traction

STANDARD PREVIEW
(standards.iteh.ai)

Ta slovenski standard je istoveten z: **ISO 6237:1987**
<https://standards.iteh.ai/catalog/standards/sist/2451a287-1dce-4674-add6-c358f98b5807/sist-iso-6237-1998>

ICS:

83.180 Lepila Adhesives

SIST ISO 6237:1998 **en**

iTeh STANDARD PREVIEW
(standards.iteh.ai)

SIST ISO 6237:1998

<https://standards.iteh.ai/catalog/standards/sist/2431a287-1dce-4674-add6-c358f98b5807/sist-iso-6237-1998>

INTERNATIONAL STANDARD

ISO
6237

First edition
1987-03-15



INTERNATIONAL ORGANIZATION FOR STANDARDIZATION
ORGANISATION INTERNATIONALE DE NORMALISATION
МЕЖДУНАРОДНАЯ ОРГАНИЗАЦИЯ ПО СТАНДАРТИЗАЦИИ

Adhesives — Wood-to-wood adhesive bonds — Determination of shear strength by tensile loading

*Adhésifs — Joints collés de bois à bois — Détermination de la résistance au cisaillement
par effort de traction*

(standards.iteh.ai)

SIST ISO 6237:1998

<https://standards.iteh.ai/catalog/standards/sist/2431a287-1dce-4674-add6-c358f98b5807/sist-iso-6237-1998>

Foreword

ISO (the International Organization for Standardization) is a worldwide federation of national standards bodies (ISO member bodies). The work of preparing International Standards is normally carried out through ISO technical committees. Each member body interested in a subject for which a technical committee has been established has the right to be represented on that committee. International organizations, governmental and non-governmental, in liaison with ISO, also take part in the work.

Draft International Standards adopted by the technical committees are circulated to the member bodies for approval before their acceptance as International Standards by the ISO Council. They are approved in accordance with ISO procedures requiring at least 75 % approval by the member bodies voting.

International Standard ISO 6237 was prepared by Technical Committee ISO/TC 61, *Plastics*.

Users should note that all International Standards undergo revision from time to time and that any reference made herein to any other International Standard implies its latest edition, unless otherwise stated.

iTeh STANDARD PREVIEW
(standards.iteh.ai)

Adhesives — Wood-to-wood adhesive bonds — Determination of shear strength by tensile loading

1 Scope and field of application

This International Standard specifies a method for determining the shear strength of wood-to-wood adhesive bonds, with a standard specimen loaded in tension and under specified conditions of preparation, conditioning and testing. This method is intended for testing only those adhesives used in bonding wood to wood in either parallel-laminated or cross-laminated construction.

NOTES

- 1 To carry out this test, basic information regarding certain variables is needed by the testing laboratory (see annex A).
- 2 This method is not intended for use in testing manufactured products.

2 Reference

ISO 291, *Plastics — Standard atmospheres for conditioning and testing*.

3 Apparatus

3.1 Apparatus for preparation of adhesive

3.1.1 Balance and equipment capable of measuring the proportions of the adhesive mix to within a tolerance of $\pm 1\%$.

3.1.2 Mixing equipment to ensure homogeneous mixing of the constituents with minimum aeration of the adhesive (except foamed adhesive).

3.1.3 Spreading equipment such as a **wire-wound bar, roller spreader, curtain coater or suitable hand applicators**, capable of spreading the adhesive uniformly within $\pm 5\%$ of the desired spread.

3.1.4 Equipment, designed to exert the required pressure evenly over the whole bonded area within $\pm 5\%$ of the desired value, for example a **press or clamps**. If necessary, **heated platens** capable of maintaining the prescribed temperature within $\pm 2\text{ }^{\circ}\text{C}$ during pressing.

3.2 Testing apparatus

3.2.1 Analytical balance.

3.2.2 Linear measuring device, to read to 0,05 mm, e.g. vernier caliper or micrometer.

3.2.3 Testing machine, capable of exerting a tensile force of at least 5 kN with an accuracy of $\pm 2\%$. The force shall be applied at a uniformly increasing rate in the range 2,5 to 6 kN/min or at a uniform crosshead speed between 0,5 and 1,0 mm/min. Other testing speeds may be used by agreement between the interested parties.

The testing machine shall be equipped with suitable grips and jaws so that the specimen is held tightly without slipping during testing and is held in alignment so that the stress is applied as required in clause 8.

NOTE — It is necessary for all equipment, including gauges, thermometers, etc., to be calibrated regularly, as prescribed by the testing authority of each country.

4 Test specimens

4.1 The timber species, timber quality and timber moisture content for the specimens shall be as described in annex B.

4.2 The test specimen shall be of a two-ply or three-ply construction and shall conform to the form and dimensions shown in figures 1 and 2. The test specimens shall be cut from test panels prepared as described in this clause and clause 5.

4.2.1 For the specimen of two-ply construction the grain of both plies shall be parallel to the long dimension of the specimen.

4.2.2 For the specimen of three-ply or cross-laminated construction the grain of the face plies shall be parallel to the long dimension of the specimen and the grain of the centre ply shall be parallel to the short dimension of the specimen and at right angles to the grain of the two outer plies.

NOTE — Both types are suitable for general testing of close contact adhesives but values obtained with the two different specimens are not comparable. Two-ply specimens are often used for applications where the grain of the adherends is parallel while the three-ply specimens may be preferred for adhesives predominantly used in the production of wooden panels such as plywood or particle board.

4.2.3 For adhesive quality control purposes, test a minimum of four specimens from each of three panels of similar construction.

ISO 6237 : 1987 (E)

4.2.4 Where greater precision is required, test at least 40 specimens, eight from each of five different panels of similar construction.

5 Preparation of test panels

5.1 Cut the veneer into suitable sizes and assemble in groups of two or three sheets (see 4.2).

5.2 Prepare the adhesive in accordance with the procedure specified by the manufacturer of the adhesive.

5.3 The surface to be bonded may or may not be abraded, as agreed between the interested parties. Apply the adhesive to the veneers as specified by the manufacturer of the adhesive. After the specified time has elapsed, assemble the veneers into two- or three-ply panels as described in 4.2.1 or 4.2.2, respectively. Then press the panel under the specified conditions. (See annex A.)

6 Conditioning of test panels

Upon release of pressure, condition the panels at a relative humidity of $(50 \pm 5) \%$ or $(65 \pm 5) \%$ and a temperature of $23 \pm 2 \text{ }^\circ\text{C}$, either for 7 days, or until they attain a constant mass, whichever is the longer period. (Constant mass is considered to be reached when the results of two successive weighing operations, carried out at an interval of 6 h, do not differ by more than 0,1 % of the mass of the test panels.)

Conditioning may be extended beyond this limit by agreement between the interested parties.

NOTE — Other atmospheres or test conditions may be used as agreed between the interested parties.

7 Preparation of specimens

7.1 Cut the test specimens as shown in figure 1, taking care that a margin to exclude edge effect is removed first. This is best accomplished by first cutting the notches to the proper width, depth and location in the test panel, using a hollow-ground grooving saw or any other method that will give equally satisfactory results. Notch the specimens as shown in figures 1 and 2. The notch of the two-ply specimen shall go as far as the glue line and care shall be taken that the ply is cut completely. The notch for the three-ply specimen shall go up to the second glue line. When the panel has been notched, cut the individual specimens from the panel. Number them consecutively from one end of the panel to the other and identify them with regard to panel of origin. Select the specimens to be tested so that an even and equal number of specimens is taken from each panel. The dimensions of the bond shear area as machined shall be reported.

7.2 Store the specimens in the conditioning atmosphere described in clause 6, until tested. They may be briefly removed for the cutting operation.

8 Procedure

8.1 Place the test specimen in the jaws of the grips in the testing machine (3.2.3) so that the notches are approximately 5 mm from the end of the jaws. The specimen shall be perfectly aligned and the pairs of jaws shall be directly above each other and in such a position that an imaginary straight vertical line would pass through the centre of the core ply and through the points of suspension of the grips. Test the specimens from each panel in numbered sequence and place them in the jaws alternately so that in one case the upper notch is to the left and in the other case to the right. The rate of separation of the jaws shall be such that the failure occurs within $60 \pm 20 \text{ s}$, unless other speeds are agreed upon (see 3.2.3). The rate of separation shall be reported in the test report.

8.2 Record the force at break and the percentage wood failure for each test joint, estimated as described in 8.3. Express all forces in kilonewtons to the nearest 10 N.

8.3 In order to determine the wood failure after testing, illuminate the specimen with oblique light, incident at an angle of 10° to 15° . The light source shall have a black, non-reflecting shade. A clear incandescent 150 W bulb or a 15 W fluorescent tube shall be used. The distance between the incandescent bulb and the specimen shall be between 150 and 250 mm and the distance between the fluorescent tube and the specimen shall be between 25 and 75 mm. Determine the proportion of area covered by wood, irrespective of depth of failure. If the shear fracture does not extend over the whole test area, then wood failure shall be calculated as a proportion of the fractured area.

In assessing wood failure, both sides of the fracture shall be evaluated in conjunction. The wood failure shall be evaluated to the nearest 10 %.

8.4 Eliminate all specimens that failed in tension in the wood outside the bond area.

9 Expression of results

9.1 Calculate for each specimen the force in kilonewtons or the stress in kilopascals* at break.

9.2 Calculate the mean \bar{x} and the standard deviation s of the force or stress at break and of the percentage wood failure for the specimens from each test panel and for all specimens, by the following formulae :

$$\bar{x} = \frac{\sum x}{n} \quad \text{and} \quad s = \sqrt{\frac{n\sum x^2 - (\sum x)^2}{n(n-1)}}$$

where

x is each individual result ;

n is the number of specimens tested.

* 1 kPa = 1 kN/m²

10 Test report

The test report shall include the following particulars:

- a) reference to this International Standard;
- b) complete identification of the adhesive tested, including type, source, manufacturer's code number, physical form, etc.;
- c) timber species used, its moisture content at the time of spreading, and description of bonding surfaces, including, if known, the age of the surface;
- d) application and bonding methods and conditions used in preparing the test joints;
- e) type of specimen used, i.e. two-ply or three-ply, direction of centre ply (see 4.2.2) and dimensions of bond shear area as machined;
- f) thickness of adherend used (each ply used should be recognized as an adherend);
- g) conditioning atmosphere and temperature, and conditioning procedure used for the specimens before testing;
- h) temperature and relative humidity of the test room;
- i) rate of applying force or crosshead speed and description of grips;
- j) number of test joints tested;
- k) number of panels and press loads represented;
- l) individual test results identified with regard to panel of origin and specimen numbers;
- m) mean force or stress at break and mean wood failure for each panel and for all specimens;
- n) standard deviation of force or stress at break for each panel and for all specimens;
- o) all modifications of the test procedure that may have affected the results.

iTeh STANDARD PREVIEW (standards.iteh.ai)

[SIST ISO 6237:1998](https://standards.iteh.ai/catalog/standards/sist/2431a287-1dce-4674-add6-c358f98b5807/sist-iso-6237-1998)

<https://standards.iteh.ai/catalog/standards/sist/2431a287-1dce-4674-add6-c358f98b5807/sist-iso-6237-1998>

Dimensions in millimetres

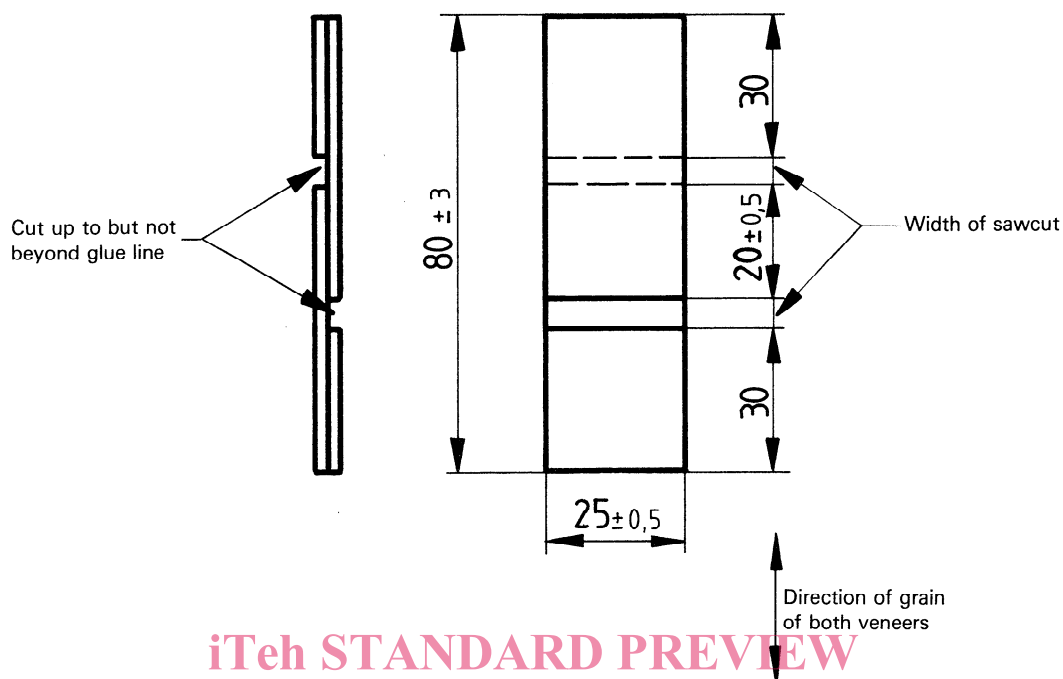

iTeh STANDARD PREVIEW
(standards.iteh.ai)

a) Two-ply tensile shear specimen

SIST ISO 6237:1998

<https://standards.iteh.ai/catalog/standards/sist/2431a287-1dce-4674-add6-c358f98b5807/sist-iso-6237-1998>

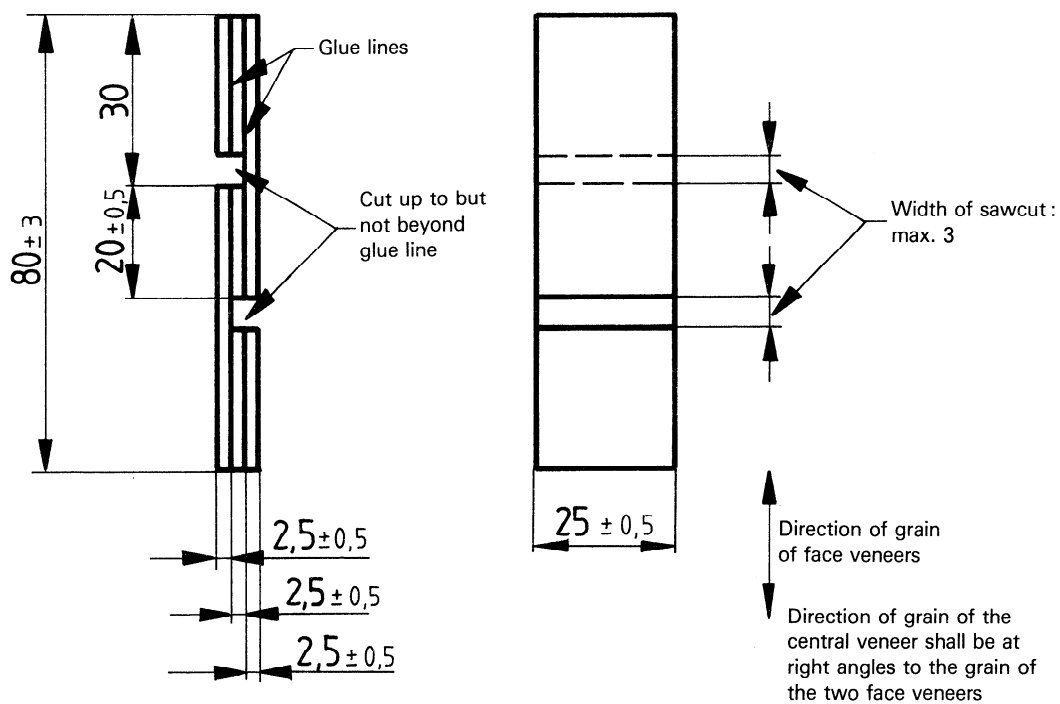

b) Three-ply tensile shear specimen

Figure 1 — Test specimens

Dimensions in millimetres

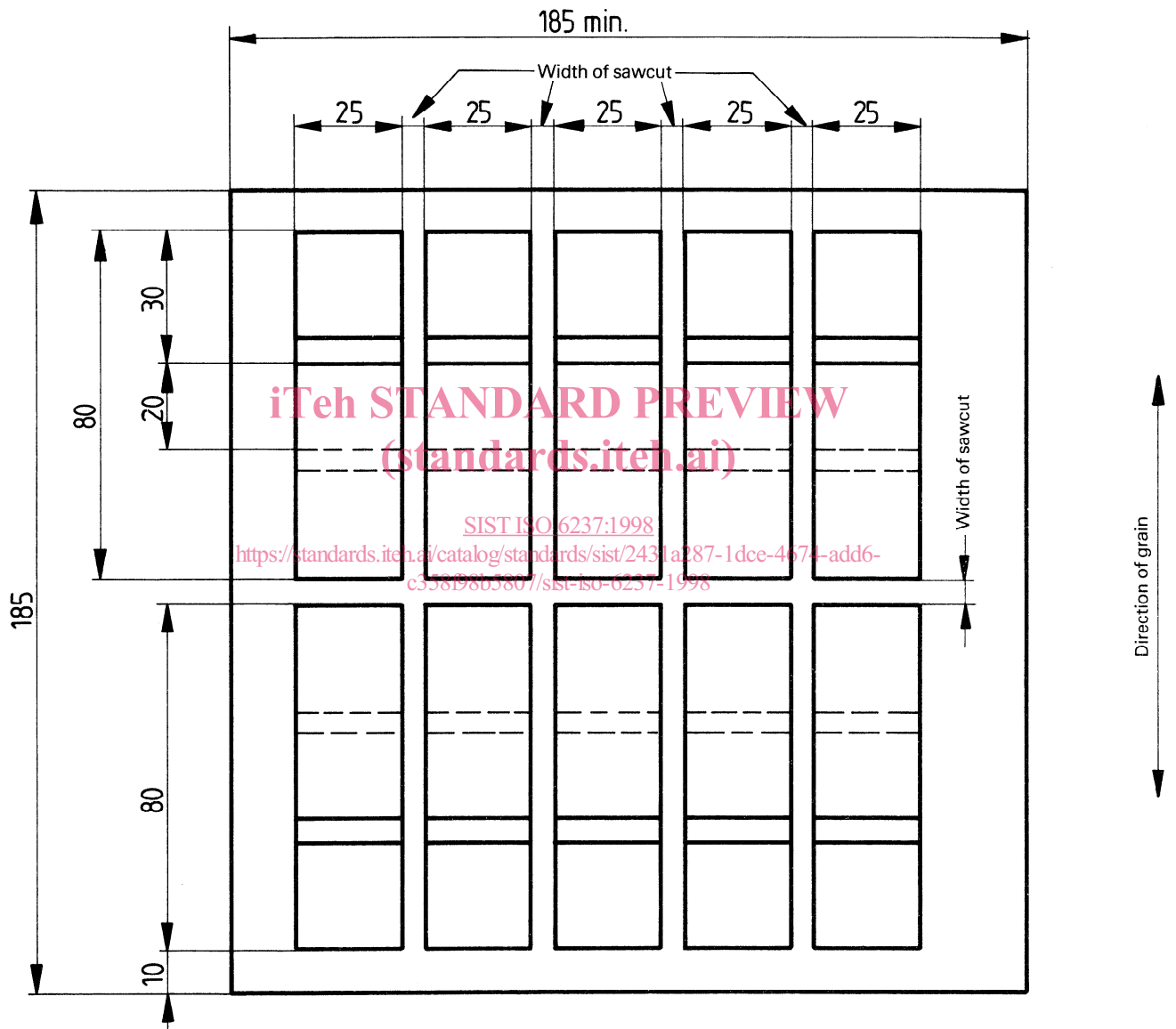

Figure 2 — Suggested arrangement of specimens