**Petroleum products — Determination
of foaming characteristics of lubricating
oils**

*Produits pétroliers — Détermination des caractéristiques de moussage
des huiles lubrifiantes*

iTeh STANDARD PREVIEW
(standards.iteh.ai)

[ISO 6247:1998](https://standards.iteh.ai/catalog/standards/sist/b3103a0b-df73-44c4-b450-447a6c8f4b49/iso-6247-1998)

<https://standards.iteh.ai/catalog/standards/sist/b3103a0b-df73-44c4-b450-447a6c8f4b49/iso-6247-1998>



Foreword

ISO (the International Organization for Standardization) is a worldwide federation of national standards bodies (ISO member bodies). The work of preparing International Standards is normally carried out through ISO technical committees. Each member body interested in a subject for which a technical committee has been established has the right to be represented on that committee. International organizations, governmental and non-governmental, in liaison with ISO, also take part in the work. ISO collaborates closely with the International Electrotechnical Commission (IEC) on all matters of electrotechnical standardization.

Draft International Standards adopted by the technical committees are circulated to the member bodies for voting. Publication as an International Standard requires approval by at least 75 % of the member bodies casting a vote.

International Standard ISO 6247 was prepared by Technical Committee ISO/TC 28, *Petroleum products and lubricants*.

Annexes A and B form an integral part of this International Standard.

ITeH STANDARD PREVIEW
(standards.iteh.ai)

ISO 6247:1998

<https://standards.iteh.ai/catalog/standards/sist/b3103a0b-df73-44c4-b450-447a6c8f4b49/iso-6247-1998>

© ISO 1998

All rights reserved. Unless otherwise specified, no part of this publication may be reproduced or utilized in any form or by any means, electronic or mechanical, including photocopying and microfilm, without permission in writing from the publisher.

International Organization for Standardization
Case postale 56 • CH-1211 Genève 20 • Switzerland
Internet central@iso.ch
X.400 c=ch; a=400net; p=iso; o=isocs; s=central

Printed in Switzerland

Petroleum products — Determination of foaming characteristics of lubricating oils

WARNING – The use of this International Standard may involve hazardous materials, operations and equipment. This International Standard does not purport to address all of the safety problems associated with its use. It is the responsibility of the user of this International Standard to establish appropriate safety and health practices and determine the applicability of regulatory limitations prior to use.

1 Scope

This International Standard specifies a method for the determination of the foaming characteristics of lubricating oils at specified moderate temperatures. It is applicable to lubricants which may or may not contain additives to modify or suppress the tendency to form stable foams. The ratings used to describe the foaming tendency and/or stability are empirical.

NOTE 1 This method may be used to indicate potential problems in lubrication, cavitation and loss in systems where foam formation adversely affects equipment operation.

STANDARD PREVIEW
(standards.iteh.ai)

2 Normative references

ISO 6247:1998

<https://standards.iteh.ai/catalog/standards/sist/b3103a0b-df73-44c4-b450->

The following standards contain provisions which, through reference in this text, constitute provisions of this International Standard. At the time of publication, the editions indicated were valid. All standards are subject to revision, and parties to agreements based on this International Standard are encouraged to investigate the possibility of applying the most recent editions of the standards indicated below. Members of IEC and ISO maintain registers of currently valid International Standards.

ISO 3696:1987, *Water for analytical laboratory use – Specification and test methods*.

ISO 6353-2:1983, *Reagents for chemical analysis – Part 2: Specifications – First series*.

ISO 6353-3:1987, *Reagents for chemical analysis – Part 3: Specifications – Second series*.

3 Terms and definitions

For the purposes of this International Standard, the following definitions apply.

3.1

diffuser

device for dispersing gas into liquid

3.2

foam

a collection of bubbles formed in, or on the surface of, a liquid in which the air (gas) is the major component on a volumetric basis

3.3 lubricant

any material interposed between two surfaces that reduces the friction or wear between them

3.4 maximum pore diameter

the diameter of a capillary of circular cross-section, expressed in micrometres, which is equivalent, with respect to surface tension effects, to the largest pore of the diffuser under consideration

3.5 permeability

the flow of gas through the gas diffuser, in millilitres per minute, under a gas pressure of 2,45 kPa

4 Principle

The test portion, maintained at 24 °C, is blown with air at a constant rate for 5 min, then allowed to settle for 10 min. The volume of foam is measured at the end of each period. The test is repeated on a second test portion at 93,5 °C, and then, after collapsing the foam, at 24 °C.

5 Reagents and materials

During the analysis, unless otherwise stated, use only reagents specified in ISO 6353-2 and ISO 6353-3, if listed there, or of analytical reagent grade, and water conforming to grade 3 of ISO 3696.

5.1 Heptane.

5.2 Methylbenzene (toluene).

5.3 Acetone.

ISO 6247:1998
<https://standards.iteh.ai/catalog/standards/sist/b3103a0b-df73-44c4-b450-447a6c8f4b49/iso-6247-1998>

5.4 Propan-2-ol.

5.5 Detergent, non-ionic, soluble in water.

5.6 Butylphthalate, for flowmeter (6.4) if required.

6 Apparatus

6.1 Foaming test apparatus, illustrated in figure 1, and consisting of the following:

6.1.1 Graduated cylinder, of 1 000 ml capacity, graduated in 10 ml increments. The distance from the inside bottom to the 1 000 ml graduation shall be 335 mm to 385 mm. The top shall be circular, and if cut, shall be smoothed by fine polishing or grinding.

NOTE 2 Cylinders with spouts can have the top portion cut off below the spout to produce the circular top.

6.1.2 Stopper, of rubber or other suitable material, to fit the circular top of the graduated cylinder. There shall be a central hole to accommodate the air-inlet tube, and a second off-centre hole to accommodate the air-outlet tube.

6.1.3 Diffuser, spherical, of fused crystalline alumina grain with a diameter of 25,4 mm, or cylindrical, of sintered 5 µm porous stainless steel, and conforming to the following specification as measured by the procedures specified in annex A.

Pore diameter: 80 µm maximum
Permeability: 3 000 ml/min to 6 000 ml/min

NOTE 3 Diffusers may be attached to the air-inlet tube by any convenient means. A suitable arrangement is shown in figure 2.

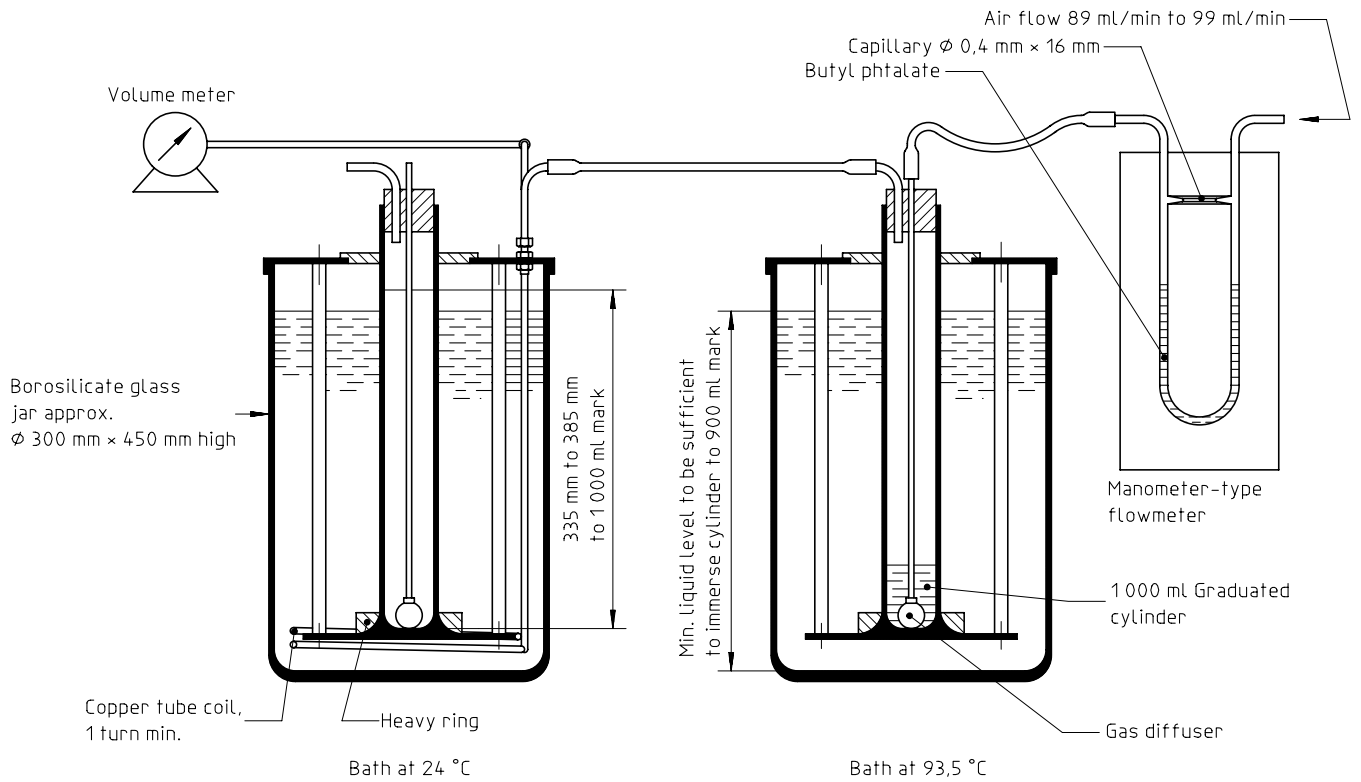

Figure 1 — Foaming test apparatus
(standards.iteh.ai)

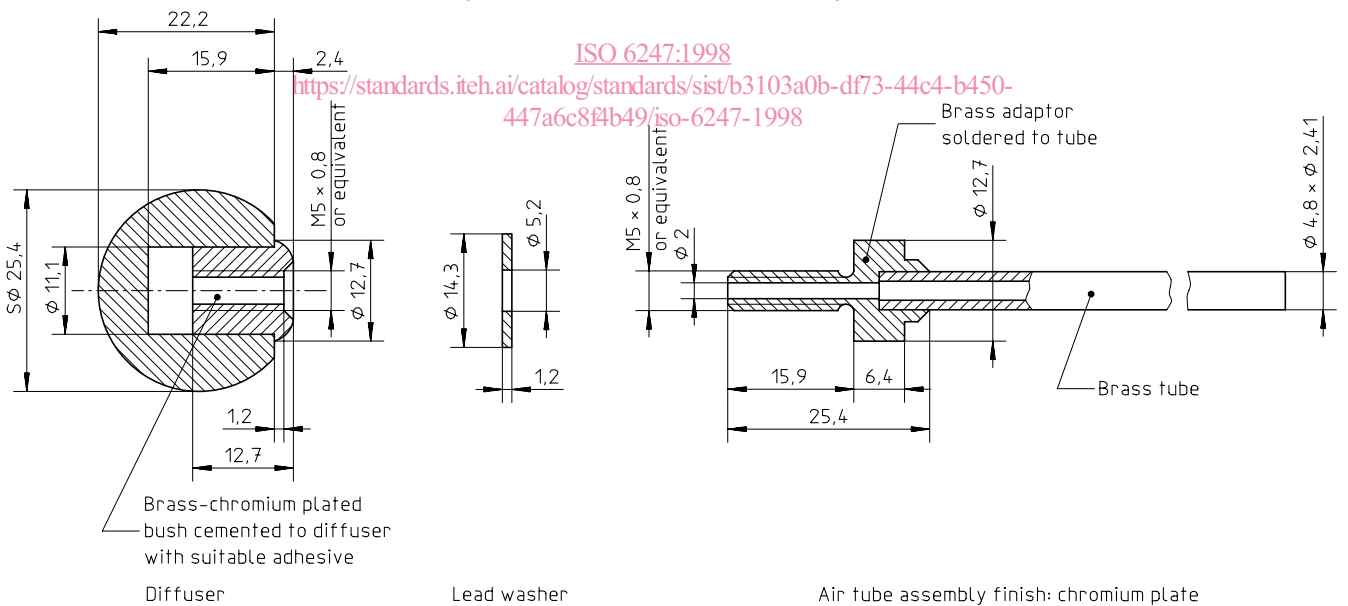

Figure 2 — Suitable attachment of diffuser to air inlet tube

6.2 Test baths, of a size sufficient to immerse the graduated cylinder (6.1.1) to at least the 900 ml mark and capable of being maintained at the specified test temperature $\pm 0,5$ °C. Both the bath and bath liquid shall be transparent enough to read graduations on the immersed cylinder.

NOTE 4 Cylindrical borosilicate glass jars approximately 300 mm in diameter and 450 mm in height make satisfactory baths.

NOTE 5 It is recommended that the 93,5 °C bath is placed inside a clear container of sufficient capacity to contain the liquid in the event of breakage.

6.3 Air supply, from a source capable of maintaining an air flow rate of 94 ml/min \pm 5 ml/min, through the gas diffuser. The air shall be passed through a drying tower 300 mm in height packed as follows: just above the constriction place a 20 mm layer of cotton, then a 110 mm layer of desiccant, a 40 mm layer of indicating desiccant, a 30 mm layer of desiccant, and a 20 mm layer of cotton. Refill the tower when the indicating desiccant begins to show the presence of moisture.

NOTE 6 Air, dried to a dew-point of -60 °C or lower and certified (accompanied by a signed certificate) to be hydrocarbon-free, does not need to be passed through the drying tower.

6.4 Flowmeter, capable of measuring a flow rate of 94 ml/min \pm 5 ml/min.

NOTE 7 A manometer-type flowmeter, in which the capillary between the two arms of the U-tube is approximately 0,4 mm in diameter and 16 mm in length, and in which butylphthalate is the manometric liquid, is suitable (see figure 1).

6.5 Volume-measuring device, capable of accurately measuring a gas volume of approximately 470 ml at a flow rate of 94 ml/min.

NOTE 8 A wet gas meter calibrated in hundredths of a litre is suitable.

6.6 Timer, electronic or manual, graduated and accurate to 1 s or better.

6.7 Temperature sensor, of the mercury-in-glass type conforming to the specification given in annex B, or an alternative calibrated temperature sensor of at least equivalent performance and accuracy at the specified immersion.

7 Preparation of the apparatus

7.1 General

Thorough cleaning of the test cylinder and air-inlet tube is essential after each use to remove any trace of additive remaining from previous tests which would seriously interfere with results of subsequent tests.

[ISO 6247:1998](https://standards.iteh.ai/catalog/standards/sist/b3103a0b-df73-44c4-b450-447a6c8f4b49/iso-6247-1998)

7.2 Cylinder

<https://standards.iteh.ai/catalog/standards/sist/b3103a0b-df73-44c4-b450-447a6c8f4b49/iso-6247-1998>

Rinse the cylinder with toluene (5.2) followed by heptane (5.1). Wash with detergent solution (5.5). Rinse the cylinder in turn with water, then acetone (5.3), and dry with a current of clean, dry air. The internal walls of the cylinder shall drain water cleanly, without drops forming.

7.3 Gas diffuser

Clean the diffuser by washing in turn with toluene and heptane. Immerse the diffuser in approximately 300 ml of solvent and flush a portion of it back and forth through the diffuser at least five times with a vacuum and air pressure. After completing the final washing in heptane, dry both the tube and diffuser thoroughly by forcing clean, dry air through them. Wipe the outside of the air-inlet tube, first with a clean cloth moistened with heptane, then with a clean dry cloth. Do not wipe the diffuser.

7.4 Assembly of apparatus

Assemble the apparatus as shown in figure 1. Adjust the air-inlet tube so that, when the stopper is fully inserted, the diffuser touches the bottom of the cylinder at approximately the centre of the cross-section. The connection between the air-outlet tube and the flowmeter (6.4) shall be made through a copper coil of at least one turn wound round the interior wall of the cold bath in order to ensure that the air volume is measured at a temperature close to 24 °C. Check the system for leaks.

Disconnect the flexible tubing from the air-inlet and air-outlet tubes and remove the stopper.

8 Procedure

8.1 Without mechanical shaking or stirring, decant approximately 200 ml of sample into a 600 ml beaker. Heat to $49\text{ °C} \pm 3\text{ °C}$ and allow to cool to $24\text{ °C} \pm 3\text{ °C}$ (see option A in 8.5.1 for stored samples).

Each step of the procedure described in 8.2 and 8.4 shall be carried out within 3 h after completion of the previous step. In 8.3, the test shall be carried out as soon as is compatible with the temperature specification and not more than 3 h after immersion of the cylinder in the bath at $93,5\text{ °C}$.

8.2 Sequence I. Pour the test portion into the graduated cylinder (6.1.1) until the liquid level is at the 190 ml mark. Immerse the cylinder at least to the 900 ml mark in the bath at 24 °C , using a heavy ring to prevent it floating. When the oil has reached the bath temperature, insert the stopper, diffuser, and the air-inlet tube with the air source disconnected, and permit the diffuser to soak for approximately 5 min. Connect the air-outlet tube to the volume-measuring device (6.5). At the end of 5 min, connect to the air source, adjust the air flow to 94 ml/min, and force clean dry air through the diffuser for $5\text{ min} \pm 3\text{ s}$, timed from the first appearance of air bubbles rising from the diffuser. At the end of this period, shut off the air flow by disconnecting the flexible tubing from the flowmeter, and immediately observe and record the volume of foam by subtracting the volume of liquid from the total volume observed in the graduated cylinder. The total air volume that has passed through the system shall be $470\text{ ml} \pm 25\text{ ml}$. Allow the cylinder to stand for $10\text{ min} \pm 10\text{ s}$ and again record the volume of foam to the nearest 10 ml.

8.3 Sequence II. Pour a second test portion of the sample into a cleaned cylinder until the oil is at the 180 ml mark. Immerse the cylinder at least to the 900 ml mark in the bath at $93,5\text{ °C}$. When the oil has reached $93\text{ °C} \pm 1\text{ °C}$, insert a clean diffuser and air-inlet tube and proceed as described in 8.2, recording the volume of foam at the end of the blowing and settling periods to the nearest 10 ml.

8.4 Sequence III. Collapse any foam remaining after 8.3 by stirring. Cool the sample to a temperature below $43,5\text{ °C}$ by allowing the test cylinder to stand in air at room temperature, then place the cylinder in the bath at 24 °C . After the oil has reached bath temperature, insert a cleaned air-inlet tube and diffuser, and proceed as described in 8.2, recording the foam volume at the end of the blowing and settling periods to the nearest 10 ml.

8.5 Certain types of lubricating oils in storage show an increase in foam levels because of a change in dispersion of the foam inhibitor. Where there is reason to suspect that this has occurred, the following option A may be used:

8.5.1 Option A. Clean the container of a 1 litre high-speed blender using the procedure given in 7.2. Place 500 ml of test sample, measured at 18 °C to 32 °C , into the container and stir at maximum speed for 1 min. Because it is normal for considerable air to be entrained during this agitation, allow to stand until entrained bubbles have dispersed and the temperature of the oil has reached $24\text{ °C} \pm 3\text{ °C}$. Within 3 h of this agitation (see note 9), start testing as described in 8.2.

NOTE 9 In the case of very viscous oils, 3 h may not be enough to disperse the entrained air. If a longer time is required, record the time, and report this with the results.

9 Alternative procedure

For routine testing, a simplified testing procedure may be used. This procedure differs from the standard method in only one respect. The total air volume used during the 5 min blowing period is not measured after the air has passed through the diffuser. This eliminates the volume-measuring equipment and the airtight connections necessary to carry the exit air from the cylinder to the volume-measuring device, but requires that the flowmeter be correctly calibrated, and that the flow rate be carefully controlled.

10 Expression of results

Express the results, to the nearest 10 ml, as 'foaming tendency' (foam volume, in millilitres, at the end of the blowing period), or as 'foam stability' (foam volume, in millilitres, at the end of the settling period). Each result shall be referenced to the appropriate sequence number, and whether the sample was tested as received, or after agitation (Option A).

When the foam or bubble layer does not completely cover the surface of the oil, and a patch, or 'eye' of clear oil is visible, report the foam volume as 'nil'.

11 Precision

The precision, as determined by statistical examination of interlaboratory test results, is given in 11.1 and 11.2 below, and is illustrated in figures 3 and 4.

For Option A, no precision statement is available.

11.1 Repeatability, *r*

The difference between successive test results obtained by the same operator with the same apparatus under constant operating conditions on identical test material would, in the normal and correct operation of the test method, exceed the following values only in one case in twenty.

$$\begin{aligned}
 r(\text{sequence II}) &= 15 + 0,33 X \\
 r(\text{other sequences}) &= 10 + 0,22 X
 \end{aligned}$$

where *X* is the mean of the values being compared.

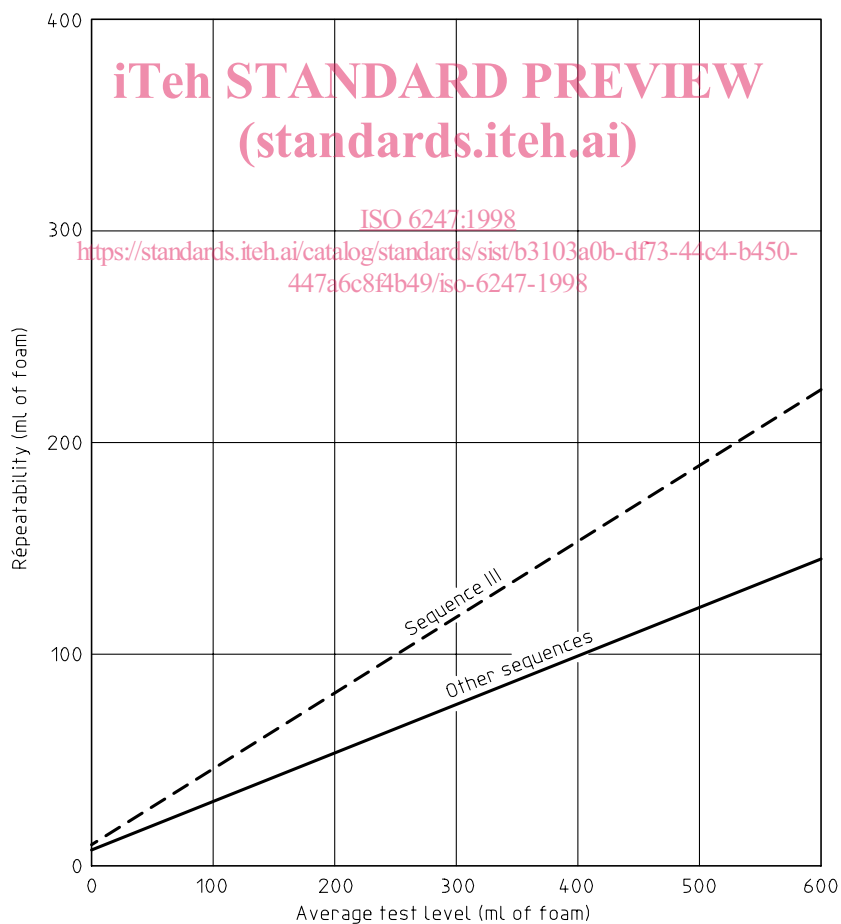

Figure 3 — Repeatability

11.2 Reproducibility, R

The difference between two single and independent results obtained by different operators working in different laboratories on nominally identical test material would, in the normal and correct operation of the test method, exceed the following values only in one case in twenty.

$$\begin{aligned} R \text{ (sequence II)} &= 35 + 1,01 X \\ R \text{ (other sequences)} &= 15 + 0,45X \end{aligned}$$

where X is the mean of the values being compared.

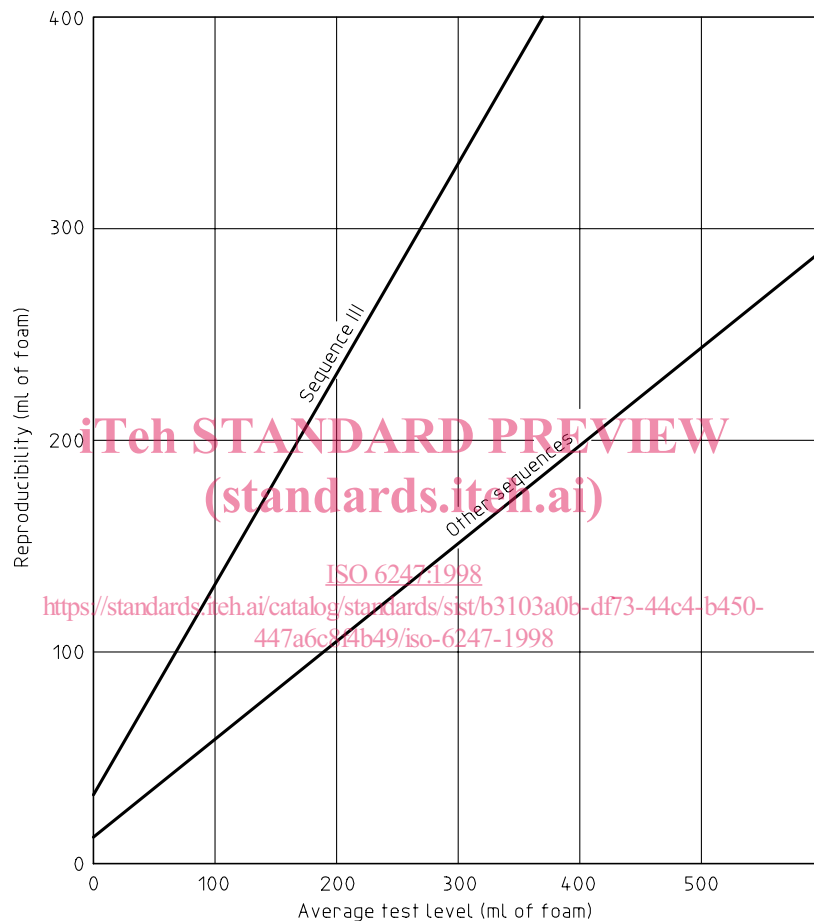

Figure 4 — Reproducibility

12 Test report

The test report shall contain at least the following information:

- a reference to this International Standard;
- the type and complete identification of the product tested;
- the result of the test (see clause 10);
- any deviation, by agreement or otherwise, from the standard procedures specified;
- the date of the test.