

# INTERNATIONAL STANDARD

**ISO**  
**6252**

Second edition  
1992-08-15

---

---

## Plastics — Determination of environmental stress cracking (ESC) — Constant-tensile-stress method

**iTeh STANDARD PREVIEW**

*(standards.iteh.ai)*  
Plastics — Détermination de la fissuration sous contrainte dans un  
environnement donné (ESC) — Méthode sous contrainte de traction  
constante

[ISO 6252:1992](#)

<https://standards.iteh.ai/catalog/standards/sist/b28a4c12-b0d0-4aee-a5c1-725e486e2fec/iso-6252-1992>



Reference number  
ISO 6252:1992(E)

## Foreword

ISO (the International Organization for Standardization) is a worldwide federation of national standards bodies (ISO member bodies). The work of preparing International Standards is normally carried out through ISO technical committees. Each member body interested in a subject for which a technical committee has been established has the right to be represented on that committee. International organizations, governmental and non-governmental, in liaison with ISO, also take part in the work. ISO collaborates closely with the International Electrotechnical Commission (IEC) on all matters of electrotechnical standardization.

Draft International Standards adopted by the technical committees are circulated to the member bodies for voting. Publication as an International Standard requires approval by at least 75 % of the member bodies casting a vote.

International Standard ISO 6252 was prepared by Technical Committee ISO/TC 61, *Plastics*, Sub-Committee SC 6, *Ageing, chemical and environmental resistance*.

<https://standards.iteh.ai/catalog/standards/sist/b28a4c12-b0d0-4ace-a5c1-129c40e243c/iso-6252-1992>

This second edition cancels and replaces the first edition (ISO 6252:1981), which has been revised to include a third method (method C).

Annex A of this International Standard is for information only.

© ISO 1992

All rights reserved. No part of this publication may be reproduced or utilized in any form or by any means, electronic or mechanical, including photocopying and microfilm, without permission in writing from the publisher.

International Organization for Standardization  
Case Postale 56 • CH-1211 Genève 20 • Switzerland

Printed in Switzerland

## Introduction

Environmental stress cracking is exhibited by many materials, including plastics. When a plastic material is stressed or strained in air below its yield point, stress cracking can occur after a period of time, which may be very long. These stresses may be internal or external, or a combination of both. Exposure to a chemical environment simultaneously with the same stress or strain may result in a dramatic shortening of the time to failure. This phenomenon is referred to as environmental stress cracking (ESC). The permissible long-term stress or strain may be reduced considerably by this phenomenon.

The cracks produced may penetrate completely through the thickness of the material, separating it into two or more pieces, or they may be arrested on reaching regions of lower stress or different material morphology.

The determination of ESC is complex because it is influenced by many parameters, including:

- test specimen dimensions;
- test specimen state (orientation, structure, internal stresses);
- stress and strain;
- temperature of test;
- duration of test;
- chemical environment;
- test method;
- failure criterion.

By keeping all but one parameter constant, the influence of the variable parameter on ESC can be assessed. The main objective of ESC measurements is to determine the effect of chemical media (environment) on plastics (test specimens and articles). The measurements may also be used to evaluate the influence of the moulding conditions upon the quality of an article when the failure mode corresponds to that obtained in actual service. It may not be possible, however, to establish any direct correlation between the results of short-duration ESC measurements on test specimens and the actual service behaviour of articles, because the behaviour of the latter is likely to be more complex than that of test specimens.

**iTeh STANDARD PREVIEW**  
This page intentionally left blank  
**(standards.iteh.ai)**

ISO 6252:1992

<https://standards.iteh.ai/catalog/standards/sist/b28a4c12-b0d0-4aee-a5c1-725e486e2fec/iso-6252-1992>

# Plastics — Determination of environmental stress cracking (ESC) — Constant-tensile-stress method

## 1 Scope

This International Standard specifies methods for the determination of environmental stress cracking (ESC) of plastics when they are subjected to a constant tensile force in the presence of chemical agents.

It is applicable to test specimens prepared by moulding and/or machining and can be used both for the assessment of ESC of plastics materials exposed to different environments, and for the determination of ESC of different plastics materials exposed to a specific environment.

NOTE 1 Methods for the determination of environmental stress cracking by means of a constant-strain test are specified in ISO 4599 and ISO 4600.

## 2 Normative references

The following standards contain provisions which, through reference in this text, constitute provisions of this International Standard. At the time of publication, the editions indicated were valid. All standards are subject to revision, and parties to agreements based on this International Standard are encouraged to investigate the possibility of applying the most recent editions of the standards indicated below. Members of IEC and ISO maintain registers of currently valid International Standards.

ISO 150:1980, *Raw, refined and boiled linseed oil for paints and varnishes — Specifications and methods of test.*

ISO 291:1977, *Plastics — Standard atmospheres for conditioning and testing.*

ISO 293:1986, *Plastics — Compression moulding test specimens of thermoplastic materials.*

ISO 294:1975, *Plastics — Injection moulding test specimens of thermoplastic materials.*

ISO/R 527:1966, *Plastics — Determination of tensile properties.*

ISO 899:1981, *Plastics — Determination of tensile creep.*

ISO 2557-1:1989, *Plastics — Amorphous thermoplastics — Preparation of test specimens with a specified maximum reversion — Part 1: Bars.*

ISO 2818:1980, *Plastics — Preparation of test specimens by machining.*

ISO 3167:1983, *Plastics — Preparation and use of multipurpose test specimens.*

ISO 4599:1986, *Plastics — Determination of resistance to environmental stress cracking (ESC) — Bent strip method.*

ISO 4600:1992, *Plastics — Determination of environmental stress cracking (ESC) — Ball or pin impression method.*

## 3 Principle

A test specimen is subjected to a constant tensile force, corresponding to a stress lower than that at yield, while immersed in a specified environment at the temperature selected for testing. The time and/or stress at which the specimen breaks is recorded.

The environmental stress cracking of the test specimens is determined by one of the following methods (A, B or C), depending upon the time to rupture:

- Method A: Determination of the tensile stress leading to rupture at 100 h. This stress is obtained by interpolation of the graph of time to rupture versus applied tensile stress.
- Method B: Determination of the time to rupture under a specified tensile stress. This method is used when the time to rupture exceeds 100 h.

- Method C: Determination of the tensile stress versus time to rupture curve up to an agreed time.

NOTE 2 If creep measurements are desired, the method outlined in ISO 899 is followed.

## 4 Apparatus

**4.1 Testing device**, allowing test specimens to be submitted simultaneously to a tensile stress and to the chemical environment.

If the chemical is a liquid at the test temperature, the test specimen shall be completely immersed in it. If it is highly viscous at the test temperature, the specimens may be covered with a coating of the agent at least 2 mm thick (see clause 5).

The parts of the device that come into contact with the chemical shall be made of an inert material, for example stainless steel.

The constant tensile stress may be applied with weights (figures 1 and 2 are schematic diagrams of suitable apparatus). The force shall be accurate to  $\pm 1\%$ . Care shall be taken to ensure that there is no loss of stress in the system, for example by friction.

If the testing device has several test stations, means shall be provided to prevent the vibration occurring through failure at one station from being transmitted to the whole system.

Care shall be taken that the specimens are subjected only to forces parallel to their longitudinal axis, and not to bending or twisting forces.

**4.2 Temperature-controlled bath or room**, allowing the test system to be maintained at  $(23 \pm 1)^\circ\text{C}$  or at a higher test temperature up to  $105^\circ\text{C}$  to within  $\pm 0,5^\circ\text{C}$  (see clause 6).

**4.3 Automatic timer**, as shown schematically in figure 2, to measure the time to rupture of each specimen to 1 % or better.

**4.4 Equipment for the preparation of test specimens** by moulding (see ISO 293 and ISO 294), machining (see ISO 2818) or die cutting.

## 5 Chemical environment

The chemical environment used for the test shall be that specified in the relevant International Standard for the material tested. If nothing is specified, use

either the agent which will be in contact with the material in the expected application or a reference product agreed upon between the interested parties.

NOTE 3 Examples of reference products are:

- 95 % (V/V) ethanol — pharmaceutical quality;
- a 1 % (m/m) solution of nonylphenoxy-poly(ethyleneoxy)ethanol<sup>1)</sup> in distilled water;
- refined linseed oil (see ISO 150).

## 6 Conditioning and test conditions

### 6.1 Conditioning

Unless otherwise agreed between the interested parties, the test specimens shall be conditioned before testing for at least 24 h at  $(23 \pm 2)^\circ\text{C}$  and  $(50 \pm 5)\%$  relative humidity (see ISO 291).

### 6.2 Test temperature

The preferred test temperatures are  $(23 \pm 1)^\circ\text{C}$  and  $(55 \pm 0,5)^\circ\text{C}$ . If required, other temperatures may be used, preferably selected from the following:

$(40 \pm 0,5)^\circ\text{C}$

$(70 \pm 0,5)^\circ\text{C}$

$(85 \pm 0,5)^\circ\text{C}$

$(100 \pm 0,5)^\circ\text{C}$

or as agreed upon by the interested parties.

## 7 Test stress

### 7.1 Maximum permissible stress

The stress applied to the test specimen during the test shall be less than the tensile stress at yield of the material at the temperature of the test.

NOTE 4 As a general guide, the stress that produces an elongation of 2 % after 1 h can be taken as the maximum permissible stress. This stress can be determined by preliminary tests using several different stresses.

### 7.2 Method A

Determine the tensile stress required to cause rupture after 100 h by applying a series of stresses, the maximum stress being as defined in 7.1.

1) This detergent is an example of a suitable product available commercially. This information is given for the convenience of users of this International Standard and does not constitute an endorsement by ISO of this product.

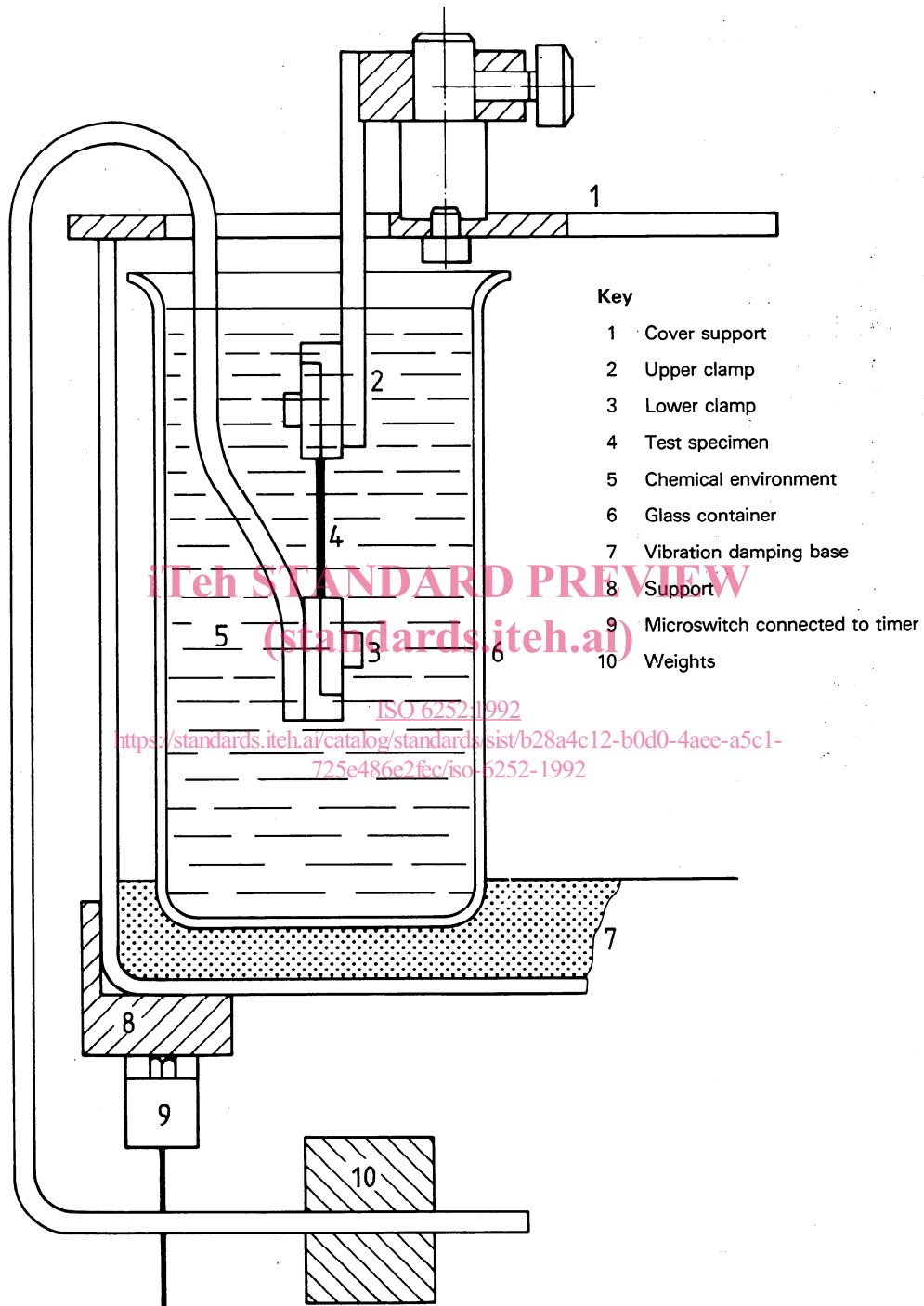

Figure 1 — One type of apparatus for measuring fracture under constant stress

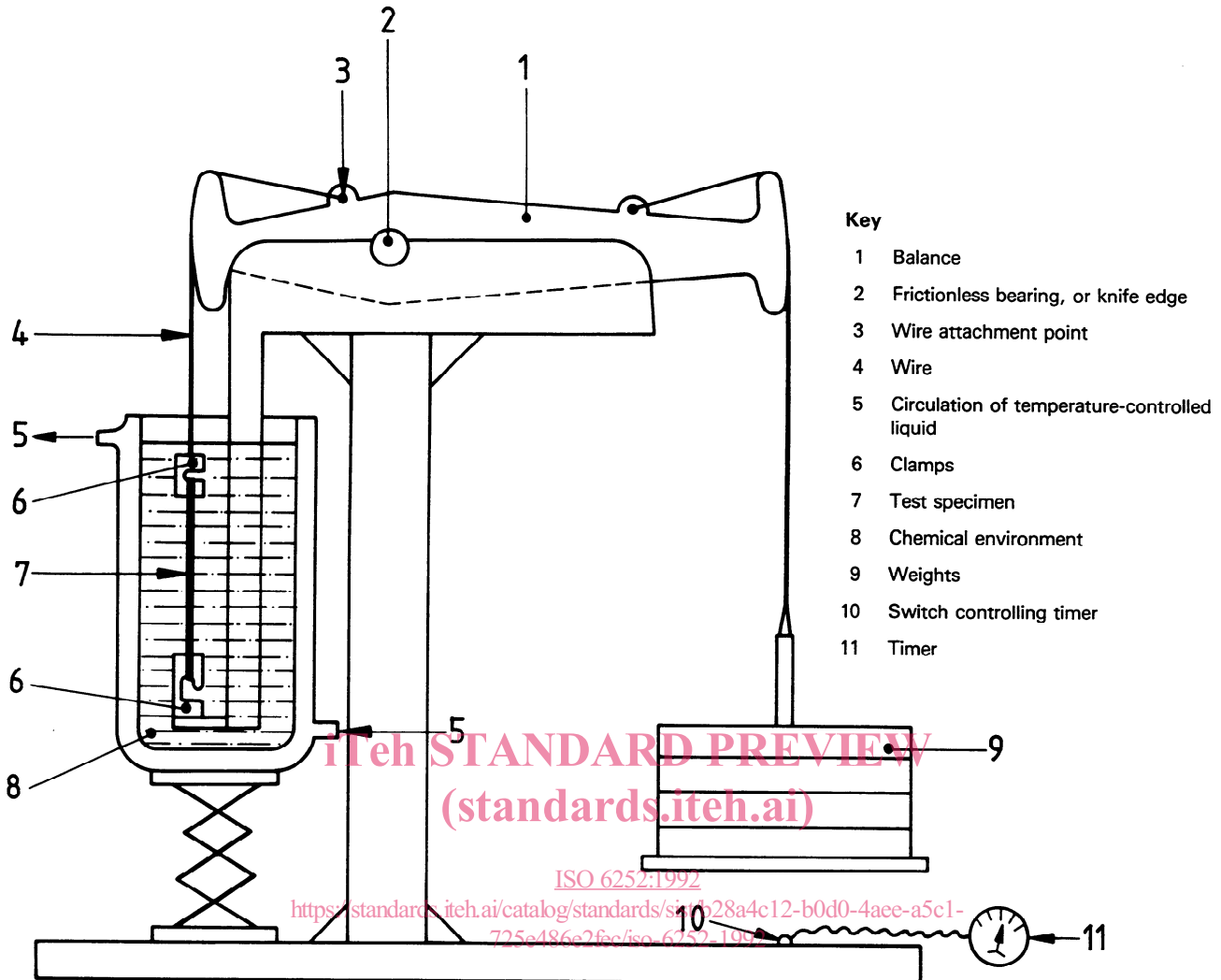

Figure 2 — Balance type of apparatus with 2:1 amplification of load

**7.3 Method B**

Determine the time to rupture under a single stress as agreed between the interested parties, but not higher than the maximum permissible stress defined in 7.1.

**7.4 Method C**

Determine the times to rupture for a series of stresses. The loads shall be chosen in accordance with 9.7.

**8 Test specimens**

**8.1 Shape and dimensions**

Use the type 1 specimen specified in ISO/R 527, with all dimensions scaled down by a ratio of 1:2 as shown in figure 3.

The preferred thickness is  $(2 \pm 0,2)$  mm, but when the test specimens are prepared from products the thickness may be that of the product. Alternatively, a type 1 specimen 3 mm to 4 mm thick may be used.

Attention is drawn to the multipurpose specimen specified in ISO 3167.

**8.2 Number**

At least five specimens shall be tested at each tensile stress in the case of methods A and B and at least two specimens for each stress in the case of method C.

If the material is thought to be anisotropic, two sets of specimens shall be used, one set cut at right angles to the other in two of the principal directions.

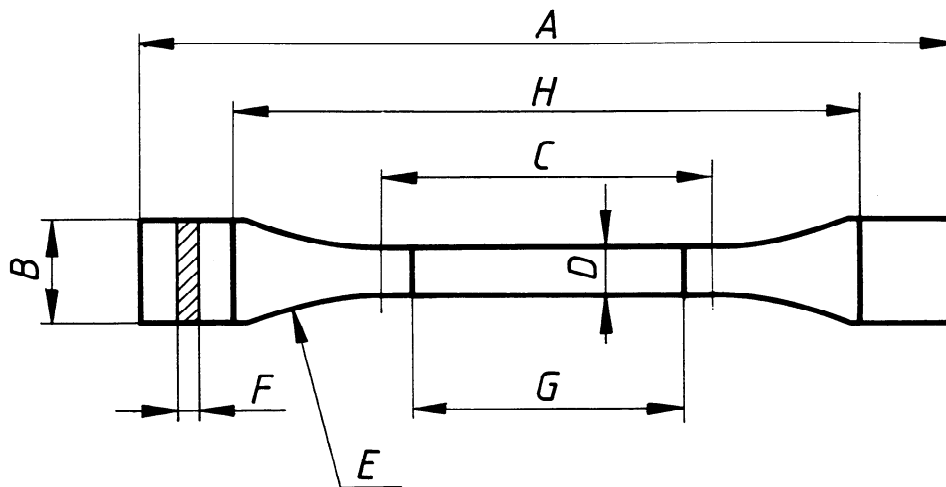

**Key**

- A* Overall length, minimum: 75 mm
- B* Width at ends: 10 mm ± 0,5 mm
- C* Length of narrow, parallel-sided portion: 30 mm ± 0,5 mm
- D* Width of narrow, parallel-sided portion: 5 mm ± 0,5 mm
- E* Radius, minimum: 30 mm
- F* Thickness: 2 mm ± 0,2 mm
- G* Distance between gauge marks: 25 mm
- H* Initial distance between grips: 57 mm

Figure 3 — ISO/R 527 Type 1 specimen (scaled down 1:2)

**8.3 Preparation**

The specimens shall be prepared in accordance with the appropriate International Standard. If nothing is stated, specimens shall be machined from sheet or from products by the methods specified in ISO 2818.

If sheets are prepared from moulding materials, they shall be moulded in accordance with the relevant material specification or as agreed between the interested parties. Specimens shall not be cut with a die unless machining is impossible, for example with soft materials.

If specimens are prepared by moulding, the procedures shall be in accordance with ISO 293 or ISO 294.

**NOTES**

5 Environmental stress cracking of a specimen is influenced not only by the material, but also by the method of preparation. Materials should only be compared using specimens prepared in a similar manner and in the same state. Attention is drawn to ISO 2557-1 for the determination of level of shrinkage.

6 Injection-moulded test specimens often have a considerable amount of orientation. If the load is applied parallel to the direction of injection, the time to rupture may be significantly longer than in the transverse direction. If the specimens are anisotropic, it may be useful to carry out tests with the load applied in different directions relative to the direction of injection.

**9 Procedure**

9.1 Measure, to the nearest 0,01 mm, the thickness and the width of the central, parallel-sided portion of each specimen and calculate the force *F*, in newtons, to be applied, using the equation

$$F = \sigma \cdot A$$

where

$\sigma$  is the stress, in megapascals, selected for the test (as described in 7.1);

*A* is the area of cross-section, in square millimetres, of the central, parallel-sided portion of the specimen.