International Standard



6257

INTERNATIONAL ORGANIZATION FOR STANDARDIZATION • МЕЖДУНАРОДНАЯ ОРГАНИЗАЦИЯ ПО СТАНДАРТИЗАЦИИ • ORGANISATION INTERNATIONALE DE NORMALISATION

Carbonaceous materials used in the production of aluminium — Pitch for electrodes — Sampling

Produits carbonés utilisés pour la production de l'aluminium — Brais pour électrodes — Échantillonnage

First edition — 1980-11-01

iTeh STANDARD PREVIEW
(standards.iteh.ai)

[ISO 6257:1980](#)

<https://standards.iteh.ai/catalog/standards/sist/04c57e23-8e89-4aa3-9db9-fba6931ce3c/iso-6257-1980>

UDC 665.775. : 669.713.7 : 620.113

Ref. No. ISO 6257-1980 (E)

Descriptors : extractive metallurgy, aluminium, pitch (materials), electrodes, sampling equipment, sampling.

Foreword

ISO (the International Organization for Standardization) is a worldwide federation of national standards institutes (ISO member bodies). The work of developing International Standards is carried out through ISO technical committees. Every member body interested in a subject for which a technical committee has been set up has the right to be represented on that committee. International organizations, governmental and non-governmental, in liaison with ISO, also take part in the work.

Draft International Standards adopted by the technical committees are circulated to the member bodies for approval before their acceptance as International Standards by the ISO Council.

International Standard ISO 6257 was developed by Technical Committee ISO/TC 47, *Chemistry*, and was circulated to the member bodies in December 1978.

iTeh STANDARD PREVIEW
(standards.itih.ai)

It has been approved by the member bodies of the following countries :

Belgium	Israel	Switzerland
Bulgaria	Italy	Turkey
China	Libyan Arab Jamahiriya	United Kingdom
Czechoslovakia	New Zealand	USA
France	Poland	USSR
Germany, F.R.	Romania	Yugoslavia
Hungary	South Africa, Rep. of	
India	Sweden	

[ISO 6257:1980](#)

<https://standards.itih.ai/catalog/standards/sist/04c57e23-8e89-4aa3-9db9-fba6931e2efc/iso-6257-1980>

No member body expressed disapproval of the document.

Carbonaceous materials used in the production of aluminium — Pitch for electrodes — Sampling

0 Introduction

Sampling is a vital step in analysis and testing. Its importance is recognized in this International Standard which specifies comprehensive methods of sampling the grades of pitch used for the electrolytic production of aluminium.

Such samples should be as representative as possible of the materials sampled (whether from the whole or part of a batch or consignment) and in a form that facilitates the determination of the distribution of values of properties.

1 Scope and field of application

This International Standard specifies methods for sampling and preparing samples prior to testing of binder pitch used in the manufacture of electrodes for the electrolytic production of aluminium.

These methods are applicable to grades of pitch in liquid or solid form, the latter having softening points higher than 30 °C (determined according to the method specified in ISO 5940) in bulk, or in a number of containers making up one batch at sites of manufacture, storage, or delivery.

2 References

ISO 3165, *Sampling of chemical products for industrial use — Safety in sampling.*

ISO 5940, *Carbonaceous materials used for the production of aluminium — Pitch for electrodes — Determination of the softening point by the ring and ball method.*

ISO 6206, *Chemical products for industrial use — Sampling — Vocabulary.*

3 Definitions

For the purposes of this International Standard, the following definitions, which are taken from ISO 6206, apply :

3.1 sampling unit : A defined quantity of material having a boundary which may be physical, for example a container, or

hypothetical, for example a particular time or time interval in the case of a stream of material.

NOTES

1 A number of sampling units may be gathered together, for example in a package or box.

2 In French, the term "individu" is sometimes used, a synonym of "unité d'échantillonnage". In English, the terms "individual", "unit" and "item" are sometimes used in practice as synonyms of "sampling unit".

3.2 sample : One or more sampling units taken from a larger number of sampling units, or one or more increments taken from a sampling unit.

3.3 representative sample : A sample assumed to have the same composition as the material sampled when the latter is considered as a homogeneous whole.

3.4 sampling plan : The planned procedure of selection, withdrawal and preparation of a sample or samples from a lot (see 3.6) to yield the required knowledge of the characteristic(s) from the final sample (see 3.9) so that a decision can be made regarding the lot.

NOTE — Considerations of cost, effort and delay usually determine an acceptable sampling error.

3.5 consignment : A quantity of material covered by a particular consignment note or shipping document.

3.6 lot : The total quantity of material to be sampled using a particular sampling plan. It may consist of a number of consignments, batches or items.

3.7 batch : A definite quantity of material that may be one item or a number of items which belong together because of their manufacture or production under conditions which are presumed to be uniform.

3.8 bulk sample : A collected set of samples which do not maintain their individual identity.

3.9 final sample : A sample obtained or prepared under the sampling plan for possible sub-division into identical portions for testing reference or storage.

3.10 laboratory sample : A sample as prepared for sending to the laboratory and intended for inspection or testing.

3.11 reference sample : A sample prepared at the same time as, and identical with, the laboratory sample, which is acceptable to the parties concerned and retained for use as a laboratory sample if a disagreement occurs.

3.12 spot sample : A sample of specified number or size taken from a specified place in the material or at a specified place and time in a stream of material and representative of its own immediate or local environment.

NOTE — In English, the term "snap sample" is sometimes used as a synonym for "spot sample".

4 General procedures and precautions

4.1 Contamination of sample or of pitch being sampled

4.1.1 The sampling procedure shall in no way cause contamination of the sample or of the pitch being sampled.

4.1.2 Sample containers, sampling apparatus, ancillary sampling gear, the hands and gloves and the protective clothing of the sampler shall all be clean.

4.1.3 Pitch undergoes slow surface oxidation in the presence of air. Finely divided products, because of their large surface area per unit mass, may show a significant rise in softening point even if stored for only a short time. It is recommended therefore that finely divided reference samples should be prepared for storage by melting and resolidifying as follows :

Place sufficient of the powdered sample in a dish in an oven controlled at 50 °C above the expected softening point of the pitch, i.e. at a viscosity of 50 ± 10 Pa·s.* Leave in the oven for 2 h at this temperature. After heating, the surface of the melt should be smooth, shiny and free of skin.

If the surface of the melt is covered with froth, suggesting the presence of water, discard it and prepare another melt using a further portion of the sample which has first been dried by allowing it to stand in an evacuated desiccator in the presence of a suitable desiccant for approximately 2 h.

Pour the molten pitch without turbulence, so as to avoid entrapping air bubbles, into an air-tight metal container, allow to solidify and seal the container.

Note any froth formation, during melting, in the sample report and, in such cases, retain a separate portion of the finely-divided sample, stored in a sealed air-tight container, for the determination of water content.

4.1.4 If a sample container is opened, it shall be securely closed again as soon as possible and any damaged sealing rings shall be replaced.

4.2 Sampling for the determination of water content of solid, granular, or lump pitch

For bulk shipments of solid pitch, a series of spot samples shall be taken, for determination of water content, either from the conveyor during charge or discharge, or from the hold or compartment at the top, middle and bottom during charge or discharge. The individual samples shall be sealed immediately in air-tight containers and tested promptly to avoid loss of moisture.

4.3 Mass of laboratory and reference samples

The mass of these samples shall be 2 kg or, alternatively, at least three times the amount required for testing. In the latter case it shall never be less than 1 kg.

4.4 Safety precautions

For comprehensive safety instructions, refer to ISO 3165. In particular, however :

4.4.1 When sampling hot liquid pitch from large containers such as road or rail tanks, the sampler should be accompanied by at least one person whose task is to ensure the safety of the sampler.

4.4.2 Avoid inhalation of pitch vapour and dust and wear a mask if pitch dust is present.

4.4.3 Cleanliness of the sampler and his clothing is essential.

4.4.4 Sampling from rail tanks shall be avoided when there is a possibility of shunting operations taking place.

4.5 Suspect consignment

A consignment shall be considered suspect if

- a) a container is damaged or defective;
- b) there is any doubt as to the nature of the contents of a container, for example because of the presence of an old label or incorrect markings;
- c) there is evidence of an unexpected lack of uniformity;
- d) obvious and unusual variations are observed in the consignment.

* 1 Pa·s = 10 P (poises)

Such samples shall be fully reported and shall not be regarded as acceptable without mutual agreement between the parties concerned.

NOTE — As pitch is a supercooled liquid, some advantage is gained during crushing the sample and cleaning of apparatus by pre-refrigerating the sample.

Any work applied to the sample (e.g. punning) results in heat generation, caking and consequent segregation of the sample.

Preparation of low softening point pitches is also possible under cryogenic conditions.

5 Sampling of solid pitch

5.1 General considerations

Table 1 indicates the minimum amount of sample that shall be withdrawn initially from a container or bulk (see, however, 4.3). Large sampling errors may however arise if the material being sampled is inhomogeneous and under such circumstances, it will be necessary to increase the sample size.

Special considerations will also apply if the quantity to be sampled is small (approximately 1 t or less) or very large (approximately 1 000 t or more). For small amounts of material, the procedures specified in 5.2, 5.3 or 5.4 shall be used to obtain the laboratory sample. In the case of large quantities several 40 kg samples shall be taken. If the consignment is not in containers, the procedure specified in 5.4.5.2 shall be used to determine the optimum sample size.

Table 1 — Minimum sample size (unless the quantity to be sampled is very large or very small)

Material mass	Sample mass
t	kg
≈ 1 to 10	10
10 to 50	20
> 50	40

5.2 Massive solid pitch

5.2.1 Pitch stored in bays

Pitch stored in a bay consists of a number of superimposed layers. The following sampling procedures shall therefore be used to take account of this structure.

5.2.1.1 Representative samples and bulk samples

Divide the surface of the pitch bed roughly into rectangular portions each of area not exceeding about 180 m². Using a drill of the type shown in figure 1, drill three holes to the bottom of the bed along one diagonal of each rectangle, positioning the holes at the centre and one-sixth of the length from either end. The combined drillings from any diagonal comprise the representative sample for that portion. The combined representative samples comprise the bulk sample for the bed.

5.2.1.2 Spot samples

Drill to within 30 mm of the level to be sampled and reject the drillings. Drill for a further 30 mm. The drillings from the latter operation comprise the spot sample.

5.2.2 Pitch stored in drums or barrels

If the container was filled with molten pitch which was allowed to solidify, and if it is impractical to remelt the material for sampling, proceed as follows :

Remove one end of the container and drill two holes. The combined drillings comprise the bulk sample.

5.3 Coarse or lumpy pitch (including pencil, prills, flake and similar pitches)

5.3.1 General considerations

This type of material is likely to show the greatest variation of composition within its container. Particular care must therefore be taken in obtaining a representative sample. Larger samples are necessary for materials of large particle size or size range. A suitably sized scoop may be used for sampling, preferably of width at least six times the diameter of the largest particles. Sample size reduction shall be effected by means of riffling (8.1.1) or the flat heap procedure (8.2) after first breaking down the lumps in the final sample.

5.3.2 Small containers

Empty the contents of the container on to a clean surface and abstract from the heap a number of lumps and a quantity of fines roughly representing the particle size distribution of the material.

NOTE — The finer particles will remain near the centre of the heap whilst the coarser particles will spread away from the centre and will thus be more easily accessible.

5.3.3 Road or rail vehicles

Selectively remove sufficient material from all parts of the vehicle so that it roughly represents the particle size distribution of the material in the vehicle.

NOTE — Vibration during transit will tend to segregate the coarser particles to the surface.

5.3.4 Bulk stocks or heaps

Flatten the heap as far as possible and dig two diagonal trenches at right angles to each other. The material removed in digging the trenches comprises the final sample.

Very large bulk stocks of coarse or lumpy solids cannot be sampled satisfactorily *in situ*. Sampling shall therefore be carried out either as the stocks accumulate or as material is withdrawn.

5.3.5 Ships' holds

Sampling shall take place during loading or unloading, so as to avoid sampling only the material at the surface. Material representative of the particle size distribution shall be taken from the conveying plant or from the trucks at regular intervals during loading or unloading and combined to give the final sample.

5.3.6 Number of samples

For guidance on the number of samples, see 5.4.5.

5.4 Granular pitch

5.4.1 Method of sampling

Material in this form, generally passing a 2 mm sieve, shall be sampled by means of a sampling spear (see Figures 2 and 3) as follows :

Thrust the spear at an angle into the material with its open side underneath and give it two or three turns. With the open side uppermost, withdraw the spear carefully so that it remains filled with the material and empty the contents into the sample container.

5.4.2 Bulk stocks or heaps

Flatten the bulk as far as possible and take samples with the spear at numerous points so as to obtain as representative a sample as possible. Very large bulk stocks cannot be satisfactorily sampled *in situ*. They shall therefore be sampled either as they accumulate or as material is withdrawn.

5.4.3 Bags and sacks

Insert the spear gently at a point where the container may be easily repaired, for example at a corner or top seam. Remove any fragments of the container from the spear before emptying the contents into the sample container.

5.4.4 Casks and kegs

If the top of the container cannot be removed, use a brace and bit to bore holes through which the spear may be inserted. It is advisable to sample one portion from top to bottom and another from side to side and then to combine the two. Remove any fragments of the container from the spear before emptying the contents into the sample container.

In all cases, seal the container immediately after sampling by driving wooden pegs into the holes.

Prepare a laboratory sample from the final sample by riffling (8.1.1) or by means of the flat heap procedure (8.1.2).

5.4.5 Sampling a consignment

5.4.5.1 Consignment in containers

The minimum number of items to be sampled is given in table 2.

Table 2 — Minimum number of items to be sampled

Number of items in the lot	Minimum number of items to be sampled
1 to 10	All the items
11 to 49	11
50 to 64	12
65 to 81	13
82 to 101	14
102 to 125	15
126 to 151	16
152 to 181	17
182 to 216	18
217 to 254	19
255 to 296	20
297 to 343	21
344 to 394	22
395 to 450	23
451 to 512	24

5.4.5.2 Consignment not in containers

Determine the number of samples to be taken as follows :

Use the graph shown in figure 4 to determine the quantity of material to be sampled from the anticipated monthly deliveries. Then use the graph shown in figure 5 to determine the number of samples which should be taken to yield the required quantity of sampled material.

If the quantity of material to be sampled is less than 100 t, then not less than 10 samples shall be taken to allow for the heterogeneity of the material. The mass of each sample taken shall be between 0,5 and 1 kg, but shall be at least 20 times the mass of the largest particle.

6 Soft pitches

Pitches that are too soft at ambient temperatures to allow satisfactory blending shall be sampled by means of one of the following procedures, preferably that specified in 6.1.

6.1 Melt the pitch and samples as specified in clause 7.

6.2 If melting is impracticable, sample the container by means of an auger of the type shown in figure 6, or by any other suitable means, taking approximately 1 kg of material from each sampling point. Melt the combined samples in a suitable vessel.

7 Hot liquid pitch

WARNING — Liquid pitch used as a binder in the aluminium industry in usually stored at temperatures in excess of 150 °C. The sampler shall therefore wear protective clothing, goggles, and heat-resistant gloves.

The sample mass shall be that specified for soft pitches. Use of the water-cooled dip-rod and the pipeline sampler referred to below will minimize the loss of volatile matter.

7.1 Sampling with a water-cooled dip-rod

Representative samples may be obtained as follows :

Lower the dip-rod (see figure 7) into the liquid pitch leave for a few minutes and then turn on the supply of cooling water. Move the rod through the pitch to increase the volume of pitch explored and withdraw it slowly so that the adhering liquid pitch drains off into the bulk. Remove the sample by breaking off the solid pitch adhering to the dip-rod or, in the case of soft pitches, by scraping, and repeat the process if more is required. In obtaining larger samples, do not build one layer of pitch upon another, as such samples have a softening point higher than that of the sampled material.

Ensure that the hose connections are water-tight to prevent water dropping on to the hot pitch.

7.2 Sampling bulk liquid storage

Large capacity vertical tanks should preferably be fitted with a series of sampling cocks, arranged vertically and 1 m apart with safe and easy access. In this case, sample from each cock into a clean container after having first taken and rejected several increments.

If the tank is not fitted with sampling cocks, the liquid pitch may be sampled by means of a weighted sampling can such as the type shown in figure 8. Take samples at intervals of 1 m throughout the depth of the tank by lowering the stoppered can to the required depth, pausing to allow temperature equilibration, removing the stopper and allowing the can to fill. Remove the can and pour off a little of the sample so as to remove most of the liquid collected from levels higher during withdrawal.

In both cases, a representative sample may be obtained by combining the individual samples in a single, air-tight metal container or by storing them separately in similar containers if testing for inhomogeneity.

7.3 Sampling on discharge

Molten pitch may be sampled from a pipeline by a pipeline sampler such as that shown in figure 9.

If this facility is not available, mix the discharged material thoroughly and sample by means of a ladle of the type shown in figure 10.

8 Sample size reduction

Only a fraction of the final sample is usually required for the laboratory sample. Suitable procedures are therefore described, assuming the pitch to be in solid form.

8.1 Powder or granules

Sample size reduction may be effected either by riffling or by using the flat-heap procedure.

8.1.1 Riffling

A typical riffle, suitable for particles of approximately 5 mm, is shown in figure 11 and shall be used as follows :

Pour the final sample uniformly into the top of the riffle from which it falls uniformly and equally divided into the two bins. Reject the contents of one bin and pour the contents of the other bin through the riffle. Repeat the process until the required quantity of laboratory sample is obtained.

In view of the difficulty of cleaning riffles, it is recommended that a separate riffle be used for each type of material.

8.1.2 Flat-heap procedure

Mix the final sample adequately on a clean, impervious surface, scrape it into a heap and then flatten the heap.

Take at least 20 portions of approximately equal mass from various points distributed evenly over the flattened heap. Dig to the bottom of the heap on all occasions and ensure that the portion taken contains material from throughout the depth of the heap.

8.2 Soft pitch

Heat the final sample to about 50 °C above its expected softening point (corresponding to a viscosity of about 50 ± 10 Pa·s) determined by the method specified in ISO 5940, mix thoroughly and run off the required quantity into the sample container.

8.3 Hard pitch

For large samples, spread the final sample on to the sampling plate (see figure 12) and, if necessary, reduce the maximum particle size to less than 12 mm by means of a punner (see figure 13). Reduce the sample size to about 2,5 kg by riffling (8.1.1) or by means of the flat-heap procedure (8.1.2). Reduce the maximum particle size of the reduced sample, or of small samples, to less than 1,5 mm and again reduce the sample size to the required magnitude in a similar manner.

9 Sample containers

9.1 Size

The size of the laboratory sample container shall be such that it is nearly filled by the sample, the space left being sufficient for expansion and for subsequent mixing of the sample.

9.2 Types

9.2.1 Lever lid cans

If tin-plated cans are used, ensure that all soldered seams are soldered only externally. If melted pitch is to be poured into such cans, the temperature of the pitch shall not be higher than about 50 °C above the softening point determined according to ISO 5940. Cans shall be cleaned, even when new, as no effective visual check can be made on their cleanliness. Washing with a low-boiling solvent such as acetone and blowing dry with filtered air is a convenient method. The solvent may also be steamed out and the cans dried in an oven. Because of its toxic nature, benzene shall not be used. Suitable precautions shall be taken with combustible solvents.

9.2.2 Plastic bags

Polyethene bags may be used for all except soft and liquid pitch samples.

9.3 Labelling and storage

All sample containers shall be labelled, preferably with tie-on labels. If gummed labels are used, they shall be further secured with transparent sealing tape.

All details shall be clearly and permanently marked on the label. Samples shall be stored so as to avoid atmospheric oxidation (see 4.1.3 and 4.1.4).

10 Sampling apparatus

The designs and dimensions of the apparatus illustrated are not mandatory and are intended for guidance. Where available the use of automatic sampling devices is recommended, for example in conjunction with conveyors.

10.1 Sampling drills

A pneumatic hammer drill is used in conjunction with a four-pointed bit. The bits are fitted to the drill with shanks of various lengths (0,6 to 4,3 m). The cutting bits, illustrated in figure 1, may vary from 42 to 63 mm in diameter and have a side hole to permit escape of compressed air.

10.2 Sampling spears

Two typical designs of sampling spear are shown in figures 2 and 3. If the material is free flowing, the closed-end sampling spear (see figure 3), shall be used. The use of sampling spears is described in 5.4.

10.3 Auger

A typical simple sampling auger is shown in figure 6.

10.4 Water-cooled dip-rod

A typical design is illustrated in figure 7. Water enters at A through the branch of tee-joint and, after chilling the internal

surface of the pipe B, flows via the smaller pipe through the exit at C.

10.5 Pipeline sampler

Into the side of a vertical section of the pipeline, at least four pipe diameters from any fitting (bend, branch or valve, but not a specially designed restrictor/mixer device), and preferably on the discharge side of any pump, is fitted a tube of about 12 mm bore (see figure 9). The tube extends into the centre of the pipeline and its inner end is bevelled at 45 °C to face the flow of liquid (which must be upwards) in the pipeline. The length of tube outside the pipeline shall be as short as possible and shall terminate in a stop-cock.

10.6 Weighted sampling can

A typical design is shown in figure 8. The use of the can is described in 7.2.

10.7 Ladle

A typical design is shown in figure 10. The diameter of the ladle shall be chosen to permit easy insertion through the bung hole of the container being sampled but a sliding bar with locking nut, fitted as shown, may be used to control this action. Eight or nine serrations, at least 10 mm deep, shall be cut into the rim of the ladle.

10.8 Riffle sample divider

A typical riffle suitable for solids of approximately 5 mm particle diameter is shown in figure 11. The sample stream, passing uniformly through the apertures, is split into a number of equal elements, alternative elements of which pass into the sample bin or are rejected. It should be noted that the reduced sample may not be wholly representative of the complete sample stream.

10.9 Sampling plates and punners

A typical hard steel sampling plate is shown in figure 12. Figure 13 specifies suitable dimensions for punners of mass 2,3 and 4,5 kg.

11 Sampling report

A sampling report shall be written containing all essential information pertaining to the material sampled and the manner in which the sample was prepared. It shall contain at least the following particulars :

- reference to this International Standard and, in particular, to those clauses which have been followed;
- unambiguous sample identification marks such as name and number of the label on the sample container;
- date, and duration of sampling;
- location of the pitch (for example Bay No., Hold No.) and relevant details such as "from belt during discharge";

- e) class of sample (see clause 3);
- f) approximate size of consignment;
- g) number of portions taken, equipment used, (for example auger, spear) approximate mass of sample before sample size reduction, method of reduction, (for example riffling, flat-heap procedure);
- h) comments on abnormalities such as unusual weather conditions or obvious contamination;
- j) any operation not included in this International Standard or in the International Standards to which reference is made, or regarded as optional.

iTeh STANDARD PREVIEW
(standards.iteh.ai)

[ISO 6257:1980](https://standards.iteh.ai/catalog/standards/sist/04c57e23-8e89-4aa3-9db9-fba6931ce3c/iso-6257-1980)

<https://standards.iteh.ai/catalog/standards/sist/04c57e23-8e89-4aa3-9db9-fba6931ce3c/iso-6257-1980>

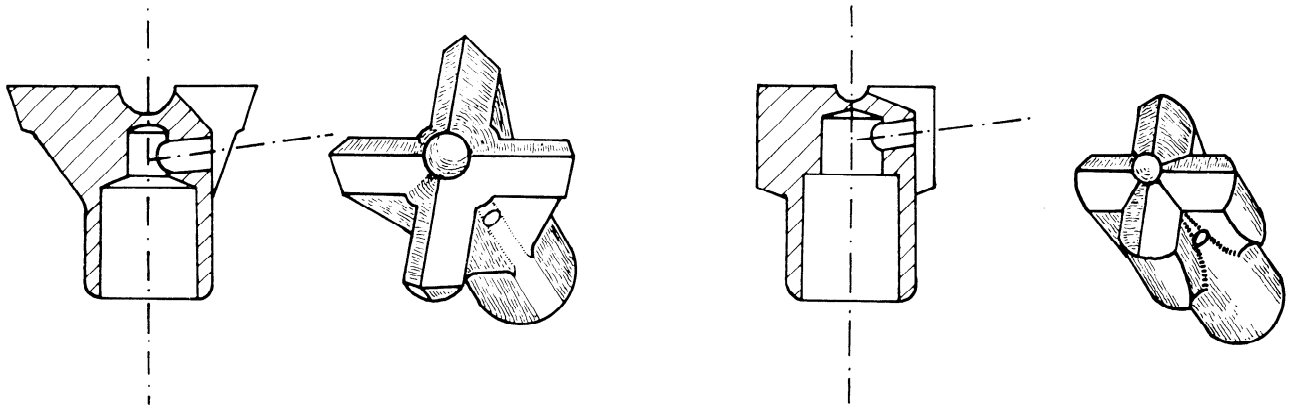

Figure 1 — Typical cutting bits for sampling drill

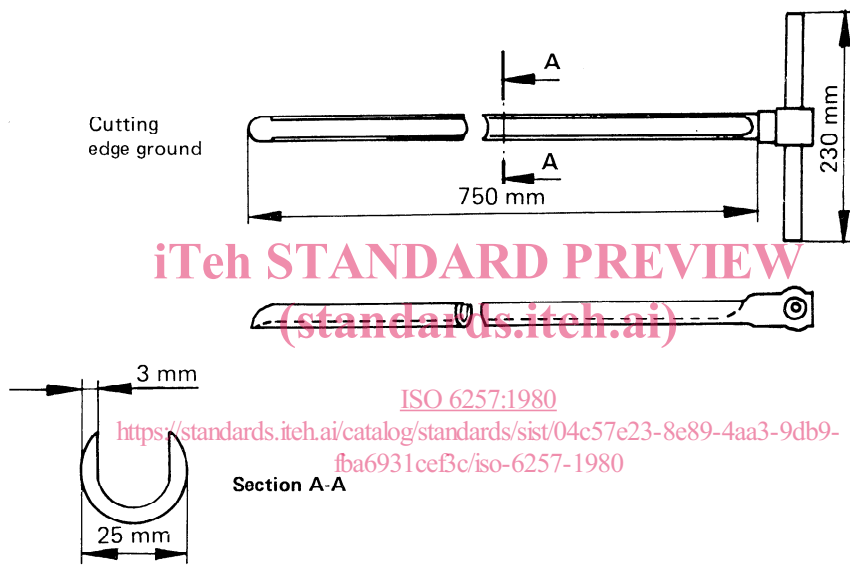

Figure 2 — Open-ended sampling spear — Typical dimensions

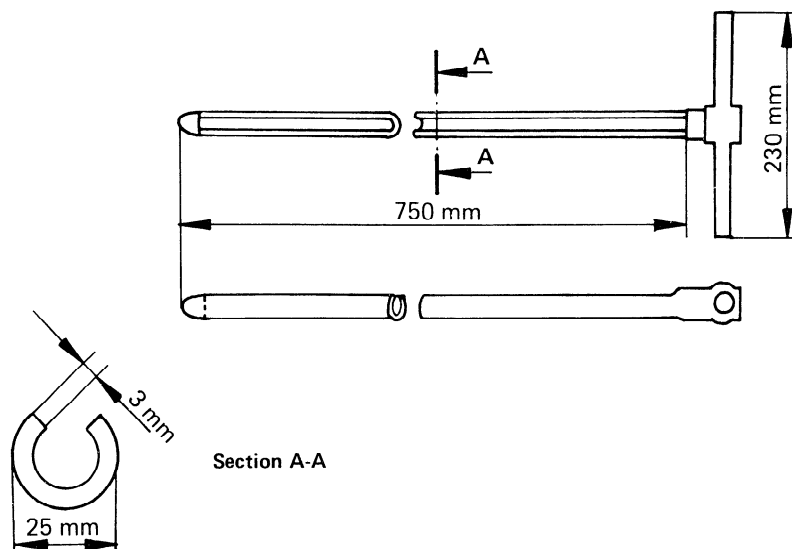

Figure 3 — Closed-end sampling spear — Typical dimensions

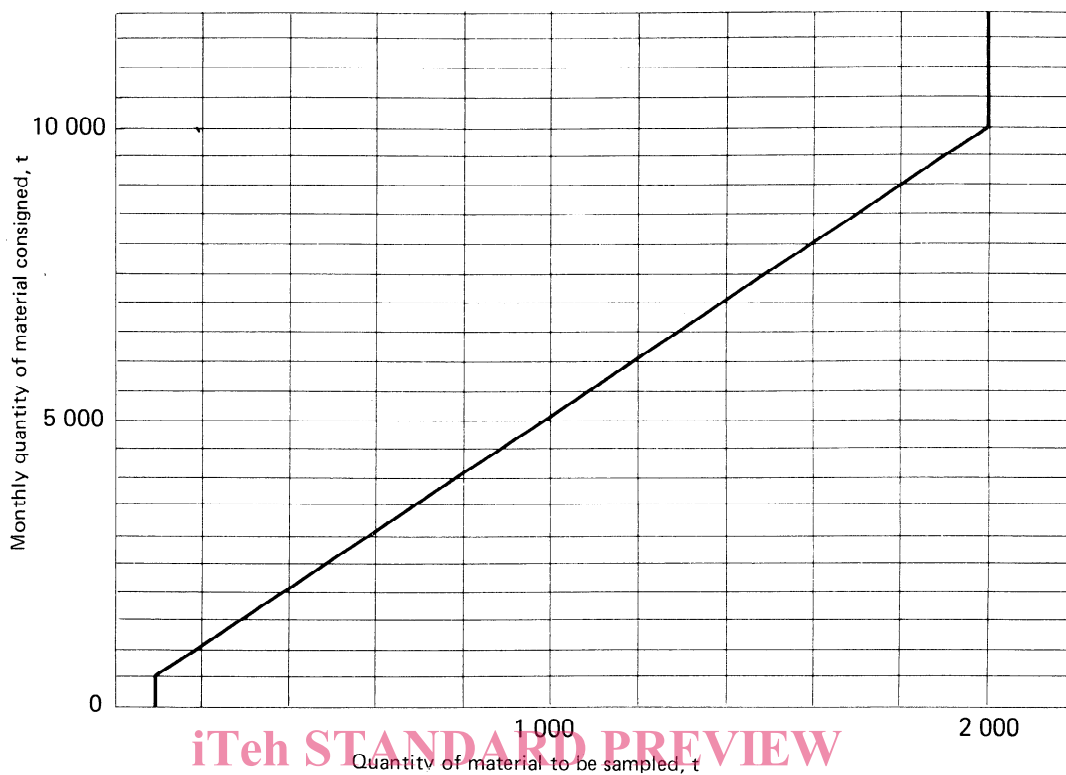

Figure 4 – Quantity of material to be sampled as a function of the monthly quantity of material consigned

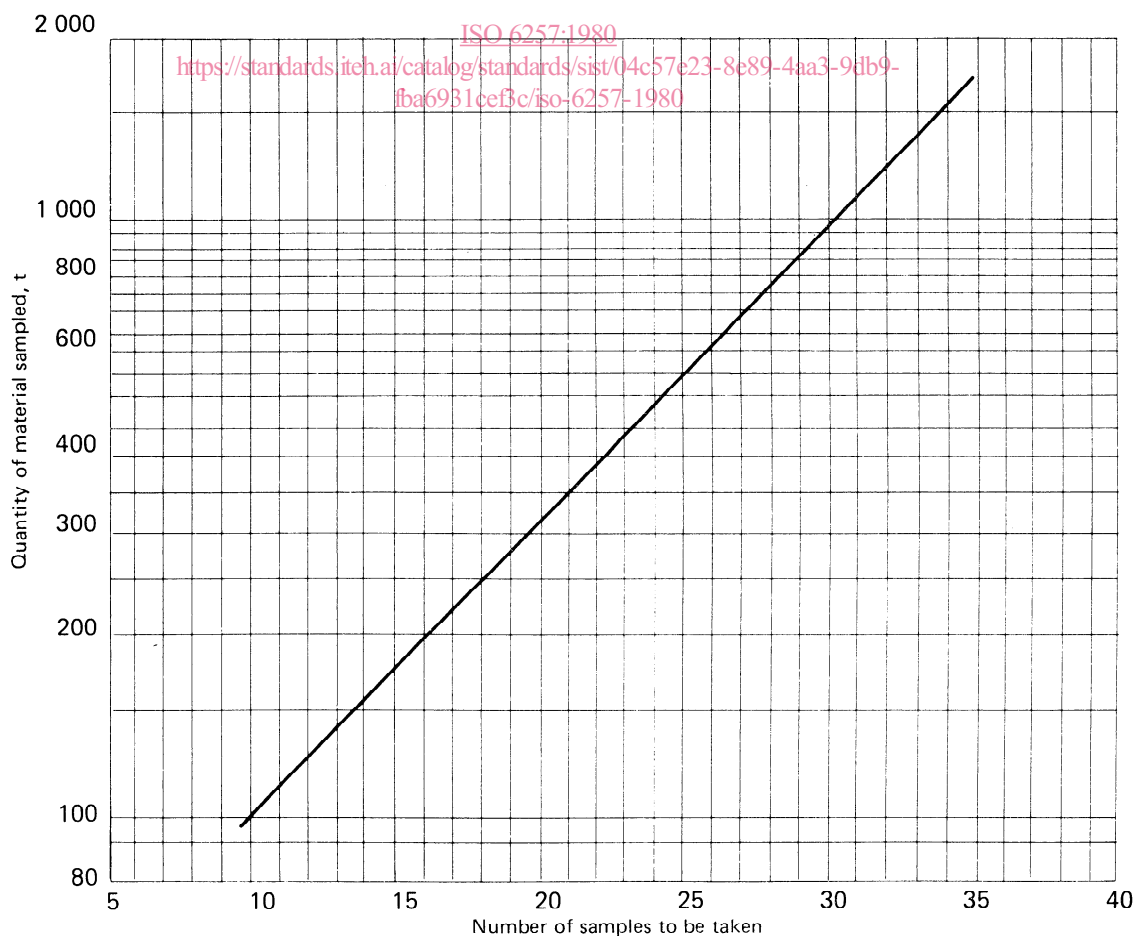

Figure 5 – Number of samples to be taken as a function of the quantity of material sampled