International Standard



6266

INTERNATIONAL ORGANIZATION FOR STANDARDIZATION • МЕЖДУНАРОДНАЯ ОРГАНИЗАЦИЯ ПО СТАНДАРТИЗАЦИИ • ORGANISATION INTERNATIONALE DE NORMALISATION

Alpine skis — Determination of fatigue indexes — Cyclic loading test

Skis alpins — Détermination des indices de fatigue — Essai en flexion alternée

First edition — 1980-10-01

iTeh STANDARD PREVIEW
(standards.iteh.ai)

[ISO 6266:1980](#)

<https://standards.iteh.ai/catalog/standards/sist/d0a26b42-49bb-4f93-9381-b011d55e6d5a/iso-6266-1980>



UDC 685.363.2 : 620.178.3

Ref. No. ISO 6266-1980 (E)

Descriptors : sport equipment, tests, mechanical tests, determination, bend tests, fatigue (materials), cyclic loads, test specimens.

Foreword

ISO (the International Organization for Standardization) is a worldwide federation of national standards institutes (ISO member bodies). The work of developing International Standards is carried out through ISO technical committees. Every member body interested in a subject for which a technical committee has been set up has the right to be represented on that committee. International organizations, governmental and non-governmental, in liaison with ISO, also take part in the work.

Draft International Standards adopted by the technical committees are circulated to the member bodies for approval before their acceptance as International Standards by the ISO Council.

International Standard ISO 6266 was developed by Technical Committee ISO/TC 83, *Sports and recreational equipment*, and was circulated to the member bodies in November 1979.

STANDARD PREVIEW
(standards.iteh.ai)

It has been approved by the member bodies of the following countries:

Austria	Italy	USA
France	Poland	USSR
Germany, F. R.	Spain	Yugoslavia
India	Switzerland	

<https://standards.iteh.ai/catalog/standards/sist/d0a26b42-49bb-4f93-9381-b011d50205a/iso-6266-1980>

No member body expressed disapproval of the document.

Alpine skis — Determination of fatigue indexes — Cyclic loading test

0 Introduction

Previous investigations showed that the fatigue of an alpine ski is not easy to describe. If one understands by fatigue the remaining negative change of some characteristics of the ski, influencing the performance of the ski, as a result of normal use, several tests would be necessary to determine exactly the susceptibility of a ski to such changes. In addition, some factors may have substantial influence on the results such as ski length, spring constant, test temperature, kind of vibration, frequency etc. It was, therefore, decided that a test method taking account of all these factors might be of some interest for ski research, but that, it should not be proposed for standardization.

Instead of this, a simplified test of the fatigue behaviour of two important characteristics of the ski (i.e. of camber height and centre spring constant) was proposed for standardization.

1 Scope and field of application

This International Standard specifies a method for the determination of the fatigue indexes of alpine skis (i.e. the resistance of the skis to changes in shape and of stiffness) after a bending test with cyclic loading.

It is applicable to

- all adults' skis;
- junior skis from 1 400 to 1 700 mm;
- children's skis from 1 000 to 1 350 mm.

2 References

ISO 5901, *Alpine skis — Geometry — Terms, definitions and measuring conditions*.

ISO 5902, *Alpine skis — Determination of the elastic properties*.

3 Definitions

3.1 original weighted bottom camber height, h_B : Weighted bottom camber height, according to ISO 5901, determined prior to the test.

3.2 final weighted bottom camber height, h'_B : Weighted bottom camber height, according to ISO 5901, determined after the test.

3.3 original centre spring constant, c_M : The centre spring constant, according to ISO 5902, measured prior to the test.

3.4 final centre spring constant, c'_M : The centre spring constant, according to ISO 5902, measured after the test.

3.5 fatigue index for the bottom camber height, K_h : The percentage change of bottom camber height of the ski after cyclic loading and recovery.

3.6 fatigue index for the centre spring constant, K_c : The percentage change of centre spring constant of the ski after cyclic loading and recovery.

3.7 stroke length, s : The deflection of the ski during cyclic loading measured from a straight line through the supports, midway between the two supports.

3.8 frequency : The number of deflections of the ski per second. The unit is the hertz.

3.9 recovery time : The time between the test and the measurement of h'_B (see 3.2) and c'_M (see 3.4), which is necessary to eliminate temporary changes in camber height and centre spring constant.

4 Principle

Subjection of the ski to cyclic loading and recovery. Determination of the fatigue indexes by calculation of the percentage permanent change in :

- a) bottom camber height;
- b) centre spring constant.

5 Apparatus

5.1 Bending machine

The bending machine shall essentially be constructed as shown in figure 1. The machine has two supports which are vertically and horizontally adjustable. The supports of the bending machine are arranged at a distance of $L_S = L_N - 280$ mm where L_N is the nominal length (see ISO 5901). The support rolls shall have a diameter of approximately 50 mm. The supports shall have a spring loaded clamping roll in order to prevent lifting of the ski.

The driving mechanism consists of a disk fly wheel with adjustable crank pin, a connecting rod and a push rod with clamping fixture. The disk fly wheel shall have sufficient mass and driving power to effect a smooth sinusoidal flexing. The distance between crank pin and rotation axis shall be adjustable

in order to be able to adjust a constant test load F_T by changing the stroke length s as indicated in 8.3.

The frequency of the stroke shall be between 2 and 3 Hz. The clamping fixture shall have a pivoting joint and jaws with elastic rubber layers, as shown in figure 2, in order to avoid stress concentration at the clamping point of the ski.

The dimensions of the rubber layers shall be as follows :

thickness : 4 ± 1 mm

width : 40 mm

hardness : (95 ± 5) Shore A

In addition, a counter shall be fixed to the push rod in order to record the number of cycles.

Dimensions in millimetres

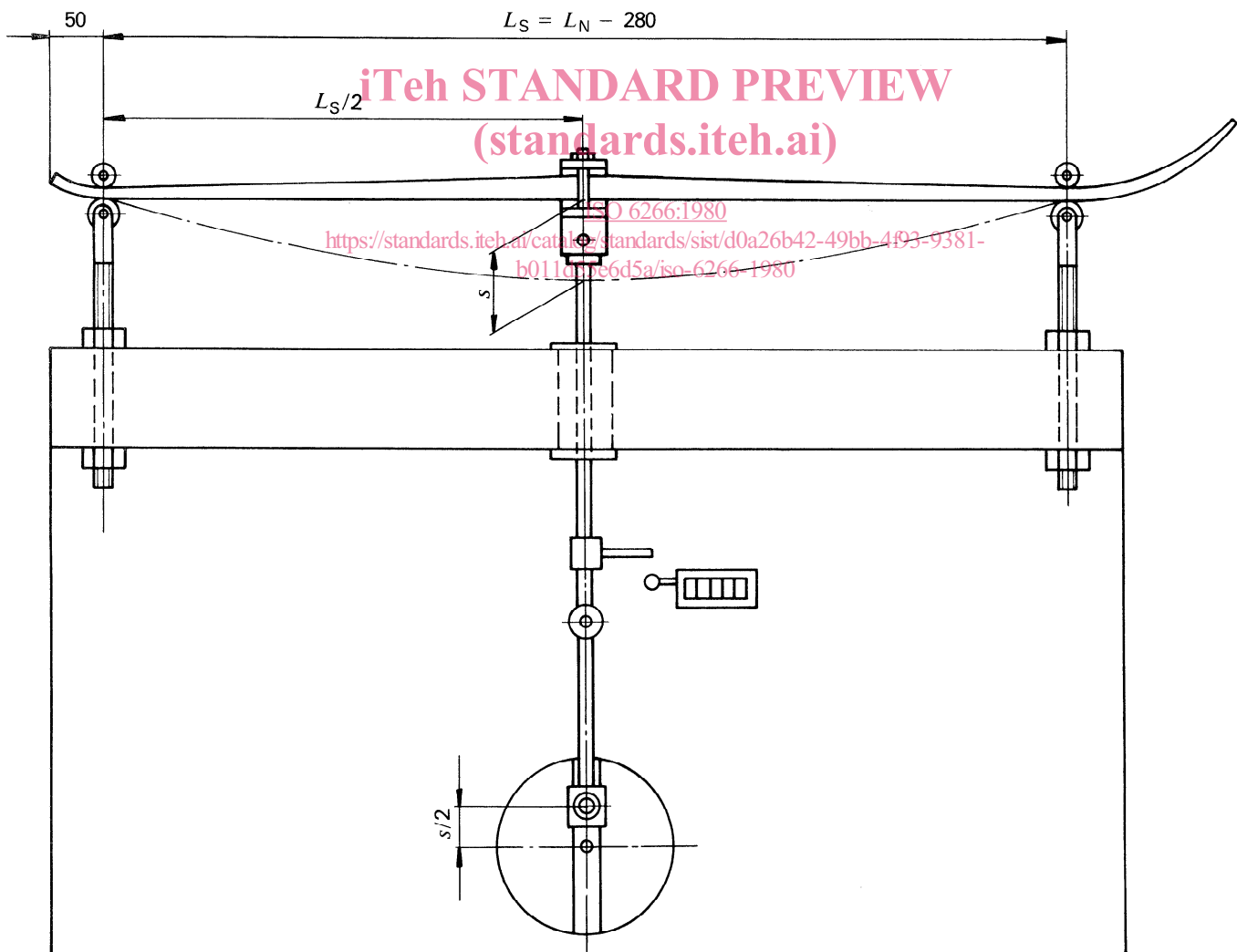
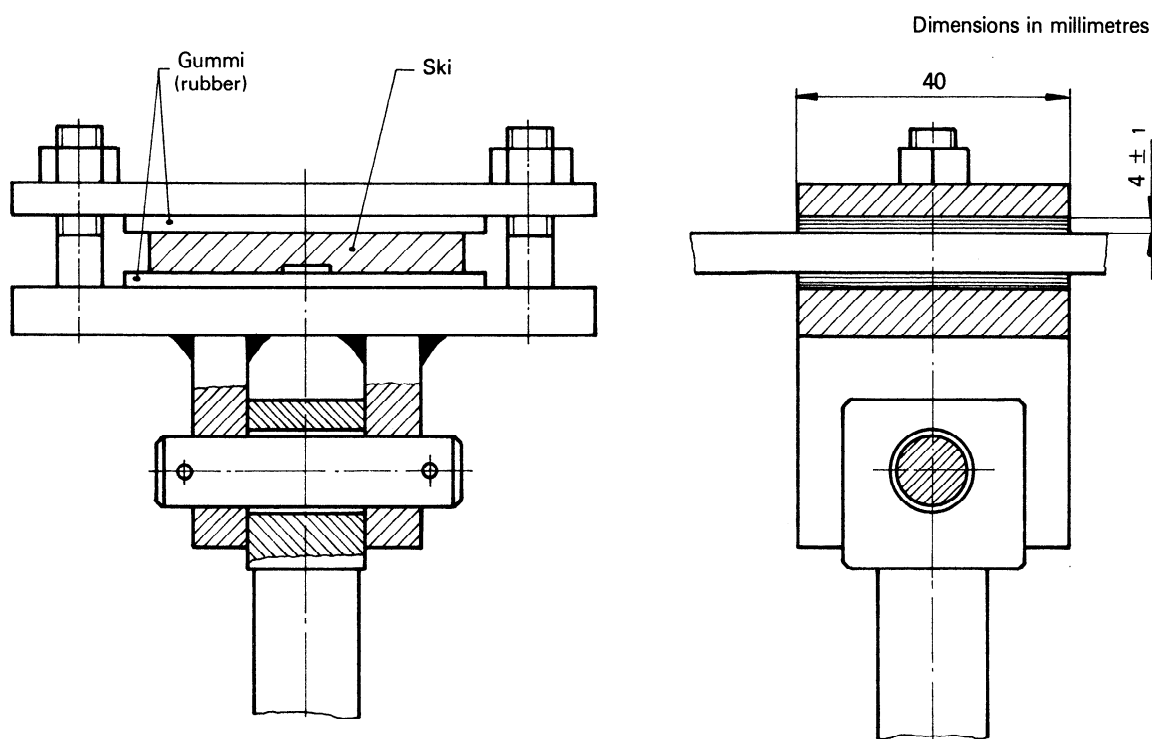

Figure 1 – Bending machine



iTeh STANDARD PREVIEW
 (standards.iteh.ai)
 Figure 2 — Clamping fixture

ISO 6266:1980

<https://standards.iteh.ai/catalog/standards/sist/d0a26b42-49bb-4f93-9381-b011d55e6d5a/iso-6266-1980>

5.2 Measuring device for bottom camber height

For measuring the bottom camber height a flat surface plate and a dial indicator with indicator holder are required.

5.3 Measuring device for centre spring constant

For measuring the centre spring constant, a device as described in ISO 5902 is required.

6 Test specimens

6.1 Lengths

To ensure the comparability of the published test results, the following ski lengths shall be used for tests :

adults' skis : 1 800 or 2 000 mm

junior skis : 1 600 mm

children's skis : 1 300 mm

6.2 Number

The test shall be carried out on 10 skis of the same type.

7 Temperatures for conditioning and testing

The fatigue properties of the ski as described in this International Standard can be affected by the test temperature to a greater or lesser extent, depending on the particular material configuration of the ski. Therefore, two different test temperatures are specified :

- A, standard laboratory test : 23 ± 2 °C;
- B, cold chamber test : -5 ± 2 °C.

All measurements shall be carried out on a ski conditioned to the test temperature for at least 2 h.

8 Procedure

8.1 Measurement of original bottom camber height, h_B

Measure the original bottom camber height h_B prior to the bending by cyclic loading. Press the ski against the flat surface plate (5.2). Place the dial indicator at the measurement point on the top surface of the ski and set to zero. Remove the flattening load, and read the bottom camber height from the dial indicator to an accuracy of $\pm 0,03$ mm.

8.2 Measurement of original centre spring constant, c_M

Measure the original spring constant c_M prior to the bending with cyclic loading, in accordance with ISO 5902, to an accuracy of $\pm 0,2$ N/mm.

8.3 Determination

Place the ski in the bending machine (5.1) and adjust the supports in such a way that the connecting line between the upper points of the lower support rolls and the surface of the clamping jaws, touching the running surface of the ski, is a straight line, when the push rod is in the upper dead centre.

Adjust the stroke length s by shifting the crank pin to its proper position. The stroke length, expressed in millimetres, is calculated from the following formula :

$$s = \frac{F_T}{c_M}$$

where

F_T is the test load, in newtons;

c_M is the original centre spring constant, in newtons per millimetre.

The permissible tolerance for stroke length is $\pm 2,5$ mm.

The following loads shall be used :

for adults' skis : 450 N

for junior skis : 350 N

for children's skis : 250 N

Subject the ski to 20 000 loading cycles at a frequency of 2 to 3 Hz.

Remove the ski from the machine and place against a wall in a vertical and stress free (relaxed) position. The recovery time for the elimination of temporary deformation is 24 h.

8.4 Measurement of final bottom camber height, h'_B

Measure the bottom camber height h'_B after the recovery time as specified in 8.1.

8.5 Measurement of final centre spring constant, c'_M

Measure the centre spring constant c'_M after the recovery time as specified in 8.2.

8.6 Assessment of damage

Visually inspect the ski for damage caused by the test (for example cracks or stress marks in the surface of the material, cracks at steel edges, delaminations, etc.).

9 Expression of results

9.1 Fatigue index for bottom camber height

The fatigue index K_h for the bottom camber height of the ski, expressed as a percentage, is given by the formula

$$K_h = \frac{h_B - h'_B}{h_B} \times 100$$

where

h_B is the original camber height, measured in accordance with 8.1;

h'_B is the final camber height, measured in accordance with 8.4.

Express the result as the mean of the 10 determinations.

9.2 Fatigue index for centre spring constant

The fatigue index K_c for the centre spring constant of the ski, expressed as a percentage, is given by the formula

$$K_c = \frac{c_M - c'_M}{c_M} \times 100$$

where

c_M is the original centre spring constant, measured in accordance with 8.2;

c'_M is the final centre spring constant, measured in accordance with 8.5.

Express the result as the mean of the 10 determinations.

10 Test report

The test report shall include the following particulars :

- a) reference to this International Standard;
- b) complete identification fo the ski (brand, model designation, nominal length and manufacturer's registration number);
- c) test temperature (A or B);
- d) fatigue index for the bottom camber height;
- e) fatigue index for the centre spring constant;
- f) damage to the ski caused by the test with exact description;
- g) any deviation from this International Standard with an explanation of the reason for the deviation.

iTeh STANDARD PREVIEW
(standards.iteh.ai)

This page intentionally left blank

[ISO 6266:1980](#)

<https://standards.iteh.ai/catalog/standards/sist/d0a26b42-49bb-4f93-9381-b011d55e6d5a/iso-6266-1980>

iTeh STANDARD PREVIEW
(standards.iteh.ai)

This page intentionally left blank

[ISO 6266:1980](#)

<https://standards.iteh.ai/catalog/standards/sist/d0a26b42-49bb-4f93-9381-b011d55e6d5a/iso-6266-1980>