

INTERNATIONAL  
STANDARD

**ISO**  
**6272**

First edition  
1993-04-01

---

---

**Paints and varnishes — Falling-weight test**

*Peintures et vernis — Essai de chute d'une masse*

**iTeh STANDARD PREVIEW**  
**(standards.iteh.ai)**

ISO 6272:1993

<https://standards.iteh.ai/catalog/standards/sist/e631be81-006f-49a5-92f8-dc2239293d56/iso-6272-1993>



Reference number  
ISO 6272:1993(E)

## Foreword

ISO (the International Organization for Standardization) is a worldwide federation of national standards bodies (ISO member bodies). The work of preparing International Standards is normally carried out through ISO technical committees. Each member body interested in a subject for which a technical committee has been established has the right to be represented on that committee. International organizations, governmental and non-governmental, in liaison with ISO, also take part in the work. ISO collaborates closely with the International Electrotechnical Commission (IEC) on all matters of electrotechnical standardization.

Draft International Standards adopted by the technical committees are circulated to the member bodies for voting. Publication as an International Standard requires approval by at least 75 % of the member bodies casting a vote.

International Standard ISO 6272 was prepared by Technical Committee ISO/TC 35, *Paints and varnishes*, Sub-Committee SC 9, *General test methods for paints and varnishes*.

This first edition cancels and replaces ISO/TR 6272:1979, which has been technically revised.

Annex A forms an integral part of this International Standard.

© ISO 1993

All rights reserved. No part of this publication may be reproduced or utilized in any form or by any means, electronic or mechanical, including photocopying and microfilm, without permission in writing from the publisher.

International Organization for Standardization  
Case Postale 56 • CH-1211 Genève 20 • Switzerland

Printed in Switzerland

# Paints and varnishes — Falling-weight test

## 1 Scope

This International Standard is one of a series of standards dealing with the sampling and testing of paints, varnishes and related products.

This International Standard specifies a test method for evaluating the resistance of a dry film of paint, varnish or related product to cracking or peeling from a substrate when it is subjected to a deformation caused by a falling weight, dropped under standard conditions.

NOTE 1 The term "impact test" has been omitted intentionally from the title of this International Standard as one important characteristic of the apparatus used is that it should produce rapid deformation rather than a true impact.

The method described can be applied

- either as a pass/fail test, the test being carried out from one drop height and with a specified mass, so as to test compliance with a particular specification; or
- as a classification test, to determine the minimum mass and/or drop height for which the coating cracks or peels from its substrate by gradually increasing the drop height and/or the mass.

## 2 Normative references

The following standards contain provisions which, through reference in this text, constitute provisions of this International Standard. At the time of publication, the editions indicated were valid. All standards are subject to revision, and parties to agreements based on this International Standard are encouraged to investigate the possibility of applying the most recent editions of the standards indicated below. Members of IEC and ISO maintain registers of currently valid International Standards.

ISO 1512:1991, *Paints and varnishes — Sampling of products in liquid or paste form.*

ISO 1513:1992, *Paints and varnishes — Examination and preparation of samples for testing.*

ISO 1514:—<sup>1)</sup>, *Paints and varnishes — Standard panels for testing.*

ISO 2808:1991, *Paints and varnishes — Determination of film thickness.*

ISO 3270:1984, *Paints and varnishes and their raw materials — Temperatures and humidities for conditioning and testing.*

## 3 Required supplementary information

For any particular application, the test method specified in this International Standard needs to be completed by supplementary information. The items of supplementary information are given in annex A.

## 4 Apparatus

Ordinary laboratory apparatus and glassware, together with the following.

**4.1 Falling-weight apparatus**, comprising the elements described in 4.1.1 to 4.1.6.

**4.1.1 Base stand**, of sufficient mass to support the die (4.1.4).

**4.1.2 Falling weight** (see figure 1), the head having the shape of a spherical sector of diameter  $(20 \pm 0,3)$  mm, and a total mass of  $(1\ 000 \pm 1)$  g.

NOTE 2 An additional weight of mass  $(1\ 000 \pm 1)$  g can be mounted on top.

1) To be published. (Revision of ISO 1514:1984)

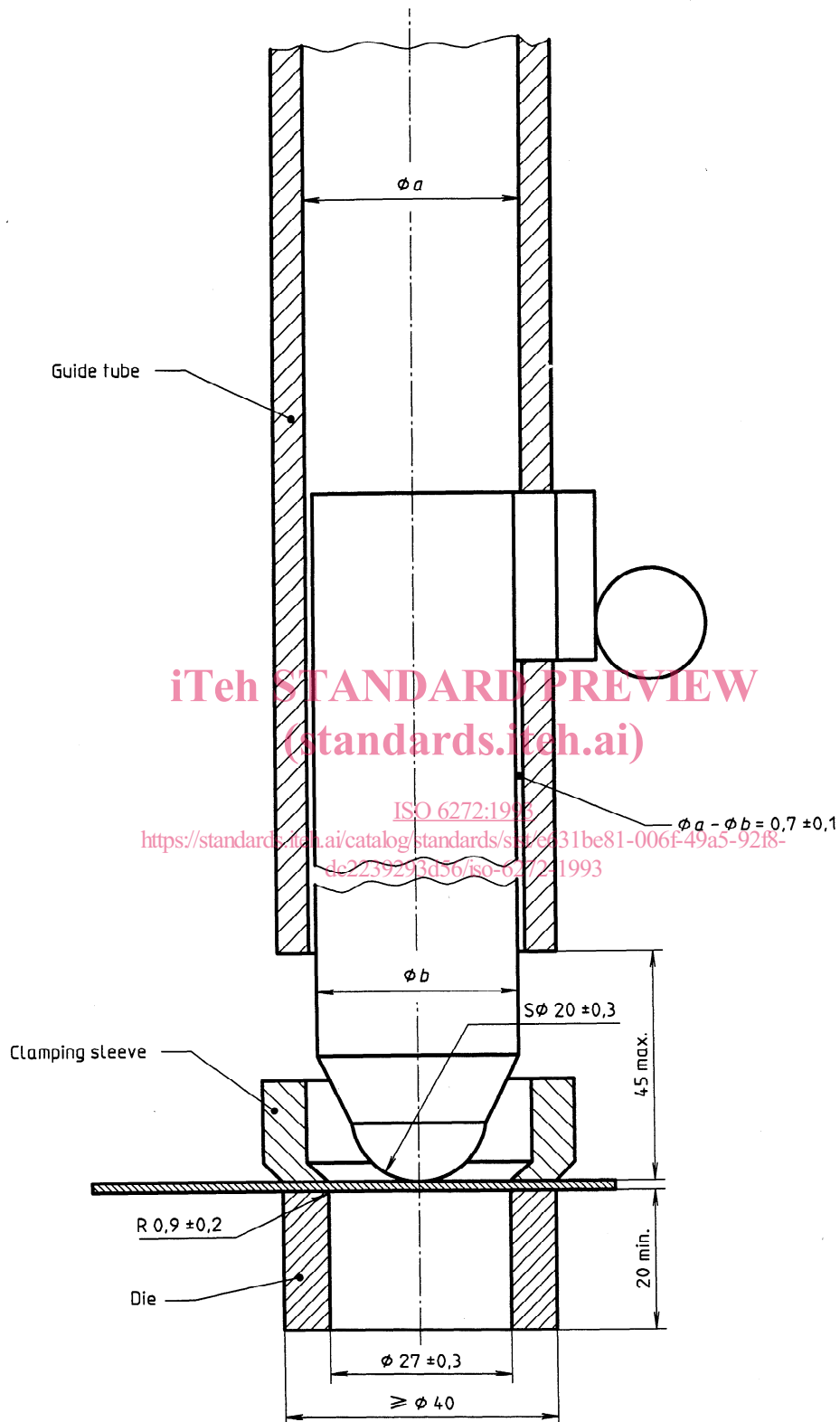

Figure 1 — Falling-weight apparatus showing required dimensions

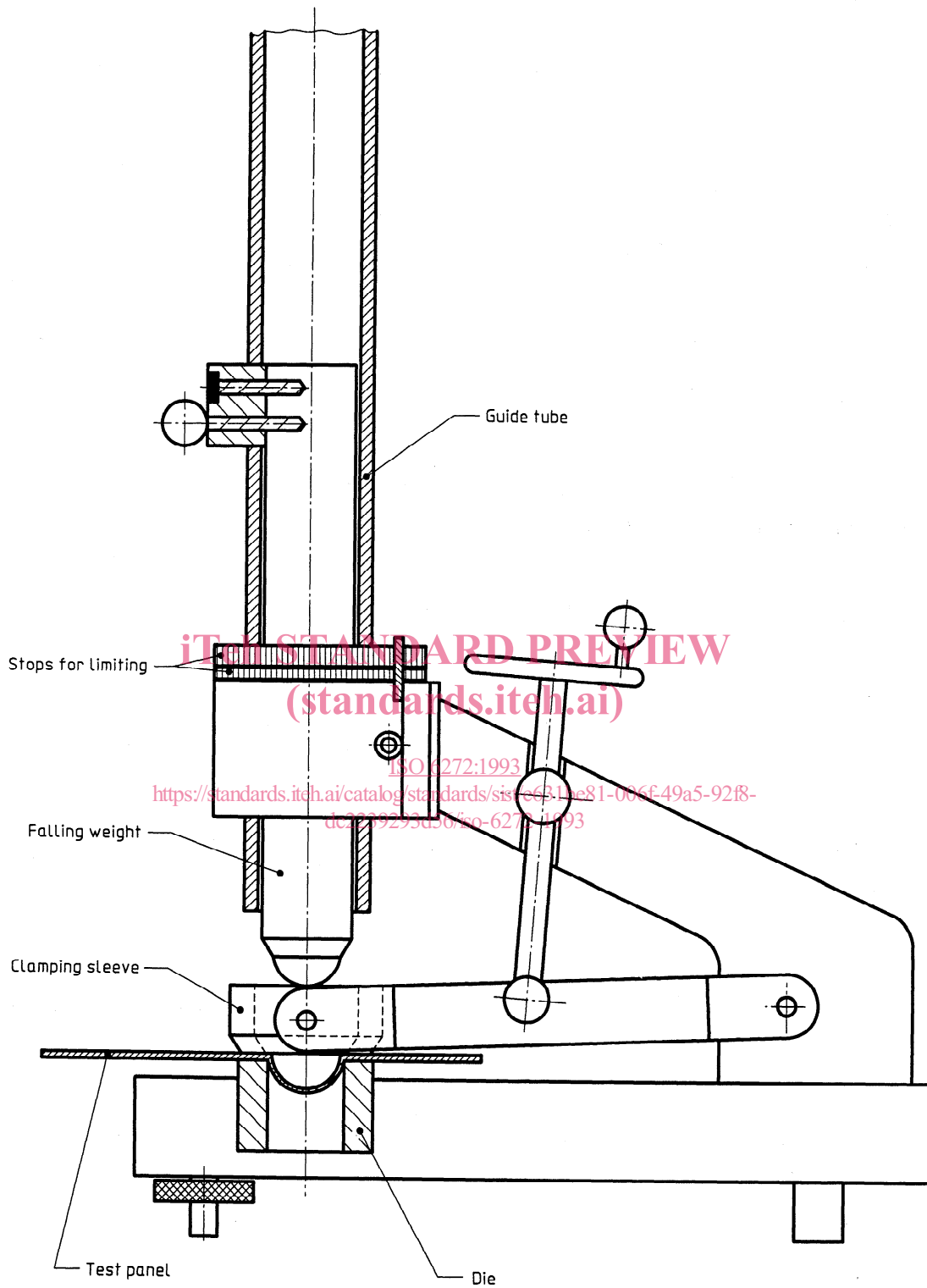

Figure 2 — Side-view of falling-weight apparatus

**4.1.3 Vertical guide tube** (see figures 1 and 2), to direct the falling weight (4.1.2) perpendicularly on to the test panel. The guide tube may be graduated, in millimetres, over 1 m from the surface of the test panel upward.

To avoid excessive friction and to ensure accurate guidance, the difference between the inner diameter of the guide tube and the outer diameter of the falling weight shall be  $(0,7 \pm 0,1)$  mm and the distance between the bottom end of the guide tube and the top of the test panel shall be not more than 45 mm.

**4.1.4 Die** (see figure 1), ring-shaped with an inner diameter of  $(27 \pm 0,3)$  mm. The inner upper edge of the ring shall be rounded, with a radius of curvature of  $(0,9 \pm 0,2)$  mm. The minimum height of the ring shall be 20 mm.

**4.1.5 Clamping sleeve** (see figures 1 and 2), to hold the test panel in position. The inner diameter at the bottom shall be the same as that of the die  $[(27 \pm 0,3)$  mm].

**4.1.6 Stops** (see figure 2), of different thicknesses, to limit the indentation depth of the falling weight.

**4.2 Viewing lens**, hand-held, with a magnification of  $\times 10$ .

## 5 Sampling

Take a representative sample of the product to be tested (or of each product in the case of a multi-coat system), as described in ISO 1512.

Examine and prepare each sample for testing, as described in ISO 1513.

## 6 Test panels

### 6.1 Substrate

Unless otherwise agreed, the substrate shall be metal, complying with the requirements of ISO 1514.

The panels shall be planar, free from distortion and at least 0,25 mm thick. The dimensions shall be such as to allow the test to be carried out for at least five different positions not less than 40 mm from each other and not less than 20 mm from the edge of the panel.

Measure the thickness to the nearest 0,01 mm.

### 6.2 Preparation and coating

Unless otherwise agreed, prepare each test panel in accordance with ISO 1514 and then coat it by the specified method with the product or system under test.

## 6.3 Drying

Dry (or stove) and age (if applicable) each coated test panel for the specified time and under the specified conditions.

## 6.4 Thickness of the coating

Determine the thickness, in micrometres, of the dried coating by one of the procedures specified in ISO 2808. Make the measurements at, or as near as possible to, the positions at which the test is to be carried out.

Use only test panels for which the film thickness values do not differ from the specified or agreed film thickness by more than 10 %.

## 7 Procedure

### 7.1 General

**7.1.1** Carry out the test at  $(23 \pm 2)$  °C and a relative humidity of  $(50 \pm 5)$  %, unless otherwise agreed (see also ISO 3270).

**7.1.2** Mount the apparatus on a firm surface (for example, concrete, steel or stone).

**7.1.3** Unless otherwise specified, immediately prior to the test, condition the panels at a temperature of  $(23 \pm 2)$  °C and a relative humidity of  $(50 \pm 5)$  % for at least 16 h.

### 7.2 Pass/fail test (using a specified mass)

Ensure that the guide tube (4.1.3) is vertical. Adjust it to a height such that the graduation representing the weight-release point corresponds to the specified drop height. If necessary, fit stop(s) (4.1.6) of total thickness sufficient to limit the indentation to a depth agreed between the interested parties or as otherwise specified. Place the test panel (see clause 6) on the base stand (4.1.1), with the coated face up or down, as specified [see annex A, item h)]. Hold the test panel in position by means of the clamping sleeve. Release the weight (4.1.2) and allow it to fall on to the test panel.

Examine the coating with the lens (4.2).

Report whether the coating on the test panel has cracked or has peeled from the substrate and whether or not the substrate has cracked.

Repeat the test a further four times at different positions (giving a total of five drops). Report the coating as satisfactory if at least four test positions show no cracking or peeling from the substrate.

**7.3 Classification test** (to determine the minimum drop height and mass causing cracking or peeling)

**7.3.1** Ensure that the guide tube (4.1.3) is vertical. Adjust it so that the graduation representing the weight-release point corresponds to the specified drop height. Place the test panel (see clause 6) on the base stand (4.1.1), with the coated face up or down as specified [see annex A, item h)]. Lower the clamping sleeve on to the panel. Raise the weight (4.1.2) (1 000 g) up the guide tube to a height where it is expected that no failure will occur. Release the weight (4.1.2) and allow it to fall on to the test panel.

**7.3.2** Remove the test panel from the apparatus and examine the deformed area with the lens (4.2) for cracks in the coating. If no cracks are evident, repeat the procedure at successively greater heights until cracks are observed, the increments of the height being 25 mm, or multiples of 25 mm. Note the height where cracks are observed for the first time. If no cracks are observed when the weight is dropped from the maximum height allowed by the apparatus, repeat the operation with a weight of 2 000 g.

**7.3.3** Once cracks are observed, carry out the following procedure. Release the appropriate weight and allow it to fall on to the test panel five times from each of the following heights: the height where cracks were first observed according to 7.3.2; 25 mm higher; and 25 mm lower than this height. Test in a random fashion, taking care that not all impacts from one height are made in succession on one panel.

**7.3.4** Examine the relevant areas of the coating with the lens (4.2) for cracking or peeling from the substrate and tabulate all 15 results as pass or fail. Report as the end-point of the test the mass/height

combination for which the results change from mainly passing to mainly failing.

**7.3.5** If no end-point can be established according to 7.3.4, repeat the procedure of 7.3.3 and 7.3.4, taking all three heights 25 mm higher or lower as appropriate to ensure that the end-point of the test is covered by the range of heights tested.

## 8 Precision

No precision data are currently available.

## 9 Test report

The test report shall contain at least the following information:

- a) all details necessary to identify the product tested;
- b) a reference to this International Standard (ISO 6272);
- c) the items of supplementary information referred to in annex A;
- d) a reference to the international or national standard, product specification or other document supplying the information referred to in c);
- e) the mass of the falling weight;
- f) the result of the test as indicated in 7.2 or 7.3, including whether stops (state total thickness) were used to limit the penetration depth of the falling weight;
- g) any deviation from the test method specified;
- h) the date of the test.

## Annex A (normative)

### Required supplementary information

The items of supplementary information listed in this annex shall be supplied as appropriate to enable the method to be carried out.

The information required should preferably be agreed between the interested parties and may be derived, in part or totally, from an international or national standard or other document related to the product under test.

- a) Material (including thickness) and surface preparation of the substrate.
- b) Method of application of the test coating to the substrate, including duration and conditions of drying between coats in the case of a multi-coat system.
- c) Duration and conditions of drying (or stoving) and ageing (if applicable) the coat before testing.
- d) Thickness, in micrometres, of the dry coating and method of measurement in accordance with ISO 2808, and whether it is a single coat or a multi-coat system.
- e) The procedure to be carried out, i.e. whether it is a pass/fail or a classification test.
- f) The mass of the falling weight.
- g) The height, if appropriate, from which the weight is to be dropped.
- h) Whether the weight is to fall on to the coated face of the test panel or on to the opposite side, or both.
- i) Whether stops are to be used to limit the penetration depth of the falling weight, or not.

iTeh STANDARD PREVIEW  
(standards.iteh.ai)

[ISO 6272:1993](https://standards.iteh.ai/catalog/standards/sist/e631be81-006f-49a5-92f8-dc2239293d56/iso-6272-1993)

<https://standards.iteh.ai/catalog/standards/sist/e631be81-006f-49a5-92f8-dc2239293d56/iso-6272-1993>



## **iTeh STANDARD PREVIEW**

**(standards.iteh.ai)**  
This page intentionally left blank

ISO 6272:1993

<https://standards.iteh.ai/catalog/standards/sist/e631be81-006f-49a5-92f8-dc2239293d56/iso-6272-1993>