International Standard



6308

INTERNATIONAL ORGANIZATION FOR STANDARDIZATION • МЕЖДУНАРОДНАЯ ОРГАНИЗАЦИЯ ПО СТАНДАРТИЗАЦИИ • ORGANISATION INTERNATIONALE DE NORMALISATION

Gypsum plasterboard — Specification

Plaques de parement en plâtre — Spécifications

First edition — 1980-11-01

iTeh STANDARD PREVIEW
(standards.iteh.ai)

[ISO 6308:1980](#)

<https://standards.iteh.ai/catalog/standards/sist/56969a59-989b-4865-b728-c6a3ab5f058d/iso-6308-1980>

UDC 691.311

Ref. No. ISO 6308-1980 (E)

Descriptors : plasterboards, gypsum plaster, specifications, dimensions, tests, dimensional measurement, breaking load.

Foreword

ISO (the International Organization for Standardization) is a worldwide federation of national standards institutes (ISO member bodies). The work of developing International Standards is carried out through ISO technical committees. Every member body interested in a subject for which a technical committee has been set up has the right to be represented on that committee. International organizations, governmental and non-governmental, in liaison with ISO, also take part in the work.

Draft International Standards adopted by the technical committees are circulated to the member bodies for approval before their acceptance as International Standards by the ISO Council.

International Standard ISO 6308 was developed by Technical Committee ISO/TC 152, *Gypsum, gypsum plasters and gypsum products*, and was circulated to the member bodies in July 1979.

It has been approved by the member bodies of the following countries:

Austria	Italy
Bulgaria	Poland
Germany, F. R.	Romania
India	South Africa, Rep. of
Israel	Sweden

Thailand
United Kingdom
USSR

The member body of the following country expressed disapproval of the document on technical grounds :

France

Gypsum plasterboard — Specification

1 Scope and field of application

This International Standard relates to gypsum plasterboard intended to be used as a vertical or horizontal lining in buildings, excluding that which has been subjected to secondary manufacturing operations. It includes boards manufactured to receive either direct surface decoration or gypsum plaster finishes.

It specifies the general characteristics of the boards together with appropriate test methods¹⁾ and defines types and their various applications.

2 Definitions

For the purpose of this International Standard, the following definitions apply.

- 2.1 edges** : Paper covered longitudinal sides.
- 2.2 ends** : Cut sides transverse to the edges.
- 2.3 back** : The surface having a double thickness of paper along the two edges.
- 2.4 face** : The surface on which the paper extends continuously to cover the edges.
- 2.5 length** : Dimension of the board parallel to the paper covered edges.
- 2.6 width** : Dimension of the board perpendicular to the paper covered edges.
- 2.7 thickness** : Distance between the face and the back, excluding edge profiles.

3 General

Gypsum plasterboards are selected for use according to their type, size, thickness and edge profile. The boards may be used, for example, to provide dry lining finishes to masonry walls, to ceilings, to steel or timber framed partitions, or as claddings to structural steel columns and beams, or in the manufacture of prefabricated partition panels. Alternatively, they may provide a base for gypsum plaster.

Gypsum plasterboards possess properties which make them particularly suitable for use in situations where fire protection, sound and thermal insulation are required.

The boards may be fixed by nailing, screwing, or sticking with gypsum-based or other adhesives. They may also be inserted in lay-in grids and/or secured by clips.

4 Types of products

Gypsum plasterboards consist of a gypsum core encased in, and firmly bonded to, strong durable paper liners to form flat rectangular boards. The paper surfaces may vary according to the use of the particular type of board, and the core may contain additives to impart additional properties. The longitudinal edges are paper covered and profiled to suit the application.

4.1 Types of gypsum plasterboard

Gypsum plasterboards are classified according to their use.

4.1.1 Gypsum wallboard

Gypsum wallboard has a face to which decoration may be applied.

4.1.2 Gypsum wallboard with reduced water absorption rate

These boards have additives in the core and/or the paper liners to reduce the water absorption rate. They may be suitable for

iTeh STANDARD PREVIEW
(standards.iteh.ai)
ISO 6308:1980
<https://standards.iteh.ai/catalog/standards/sist/56969a59-989b-4865-b728-c6a3ab5f058d/iso-6308-1980>

1) A future International Standard will give test methods for water absorption and cohesion of the core at high temperatures of boards with special properties.

special applications in buildings where the reduced water absorption properties are required to improve the performance of the board. Unless otherwise stated, decoration may be applied to the face.

4.1.3 Gypsum wallboard with improved core cohesion at high temperatures

These boards have mineral fibres and/or other additives in the gypsum core to improve core cohesion at high temperatures. They have a face suitable for direct decoration.

4.1.4 Gypsum plaster baseboard

These boards have a face suitable to receive gypsum plaster and may be perforated during primary manufacture.

4.1.5 Gypsum plaster baseboard with improved core cohesion at high temperatures

These boards have mineral fibres and/or other additives in the gypsum core to improve core cohesion at high temperatures. They have a face suitable to receive gypsum plaster and may be perforated during primary manufacture.

4.2 Edge and end profiles for gypsum plaster-board

The paper covered edges of gypsum wallboard are square, tapered, bevelled or rounded (see figures 1 to 4). The paper covered edges of gypsum baseboard are square or rounded (see figures 1 and 4). Other edge profiles may be produced for special purposes.

The ends of gypsum plasterboard are square cut.

5 Requirements

These requirements are general requirements and, with the exception of the requirements for breaking load which shall not apply to perforated gypsum baseboard, they shall apply to all types of gypsum plasterboard.

5.1 Gypsum wallboard

5.1.1 Dimensions

The dimensions of gypsum wallboard (see 4.1.1, 4.1.2 and 4.1.3) shall be as follows.

5.1.1.1 Width

The recommended widths are :

600, 900 and 1 200 mm.

The tolerance on width shall be $\pm \frac{0}{5}$ mm.

5.1.1.2 Length

The recommended lengths are increments of 100 mm in the range from 1 800 to 3 600 mm.

The tolerance on length shall be $\pm \frac{0}{6}$ mm.

5.1.1.3 Thickness

The recommended thicknesses are :

9,5 mm, 12,5 mm and 15 mm.

The tolerances on thickness shall be respectively :

$\pm 0,5$ mm, $\pm 0,6$ mm and $\pm 0,6$ mm.

5.1.2 Taper profile

The dimensions of tapered edges, when determined in the manner described in 7.4, shall be :

- a) depth of taper, in the range from 0,6 to 1,9 mm;
- b) width of taper, in the range from 40 to 80 mm.

5.1.3 Breaking load

The average breaking load of five rectangular specimens measuring 400 mm x 300 mm, when determined in the manner described in 7.5, shall be not less than the values given in table 1. Additionally, no individual result shall be more than 10 % below these average values.

Table 1 — Minimum breaking load

Board thickness mm	Breaking load, N	
	Transverse direction	Longitudinal direction
9,5	140	360
12,5	180	500
15,0	220	650

5.2 Gypsum baseboard

5.2.1 Dimensions

The dimensions of gypsum baseboard (see 4.1.4 and 4.1.5) shall be as follows.

5.2.1.1 Width

The recommended widths are

400 and 900 mm.

The tolerance on width shall be $\pm \frac{0}{8}$ mm.

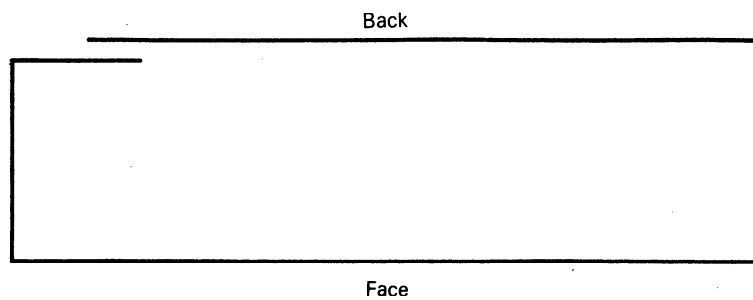

Figure 1 — Square edge

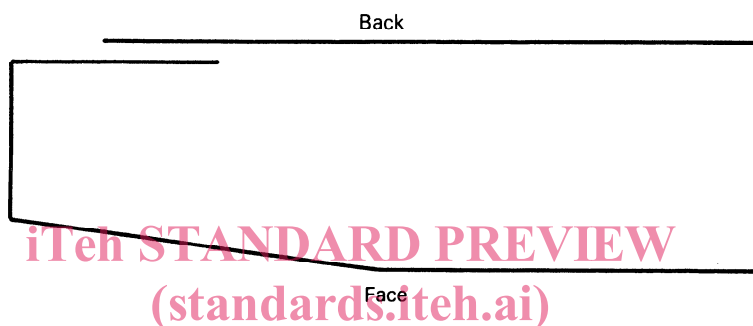

Figure 2 — Tapered edge

<https://standards.iteh.ai/catalog/standards/sist/56969a59-989b-4865-b728-c6a3ab5f058d/iso-6308-1980>

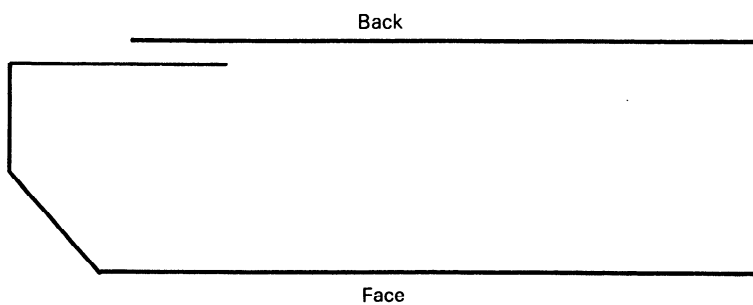

Figure 3 — Bevelled edge

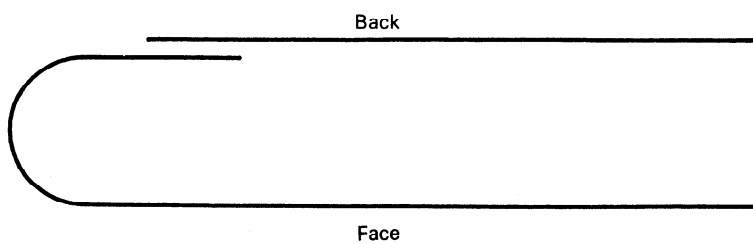

Figure 4 — Rounded edge

5.2.1.2 Length

The recommended lengths are :

1 200, 1 500 and 1 800 mm.

The tolerances on length shall be :

- a) $-\frac{0}{6}$ mm, for non-perforated baseboard;
- b) $-\frac{0}{16}$ mm for perforated baseboard.

5.2.1.3 Thickness

The recommended thicknesses are :

9,5 mm and 12,5 mm.

The tolerance on thickness shall be $\pm 0,6$ mm.

5.2.2 Breaking load

The average breaking load of five rectangular specimens measuring 400 mm \times 300 mm, when determined in the manner described in 7.5, shall be not less than the values given in table 2. Additionally, no individual result shall be more than 10 % below these average values.

This requirement does not apply to perforated baseboard.

Table 2 – Minimum breaking load

Board thickness mm	Breaking load, N	
	Transverse direction	Longitudinal direction
9,5	125	180
12,5	165	235

6 Sampling

Quality control of general production shall be the responsibility of the manufacturer, who may be required to satisfy the requirements of national legislation or be subject to regular manufacturing approval procedures, which are outside the scope of this International Standard.

A minimum of five samples shall be selected at random from each type and thickness of board. The samples shall be representative of the consignment and shall be selected to the satisfaction of the customer.

7 Methods of test and inspection

7.1 Determination of width

Take three measurements to the nearest 1 mm on each board, one on each edge and one on the axis of symmetry. Compare the average of the measurements (five samples) with the recommended widths given in 5.1.1.1 and 5.2.1.1.

7.2 Determination of length

Take three measurements to the nearest 1 mm on each board, one on each edge and one on the axis of symmetry. Compare the average of the measurements (five samples) with the recommended lengths given in 5.1.1.2 and 5.2.1.2.

7.3 Determination of thickness

Take six measurements to the nearest 0,1 mm across one end of each board (five samples), equally spaced across the width and not less than 25 mm from an end or 80 mm from an edge. In the case of boards less than 600 mm wide, only three measurements are required. Compare the average of the measurements on each board with the recommended thicknesses given in 5.1.1.3 and 5.2.1.3.

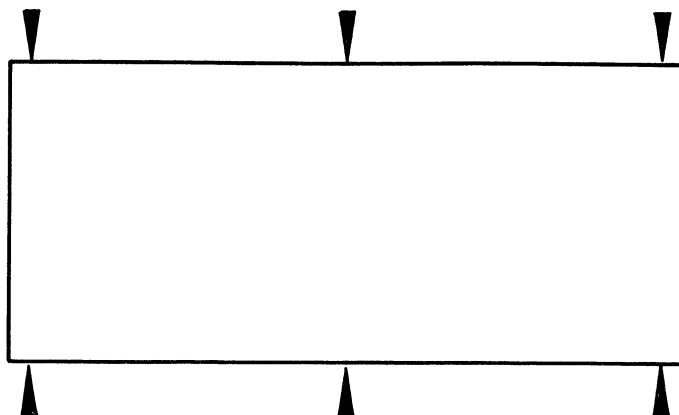

Figure 5 – Measurement of width

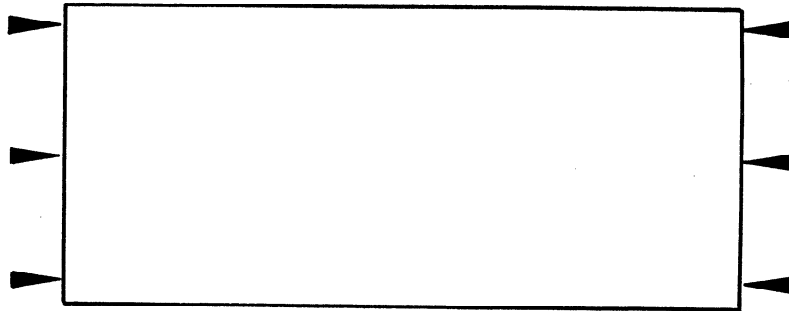

Figure 6 – Measurement of length

iTeh STANDARD PREVIEW
(standards.iteh.ai)

ISO 6308:1980

Dimensions in millimetres

<https://standards.iteh.ai/catalog/standards/sist/56969a59-989b-4865-b728-c6a3ab5f058d/iso-6308-1980>

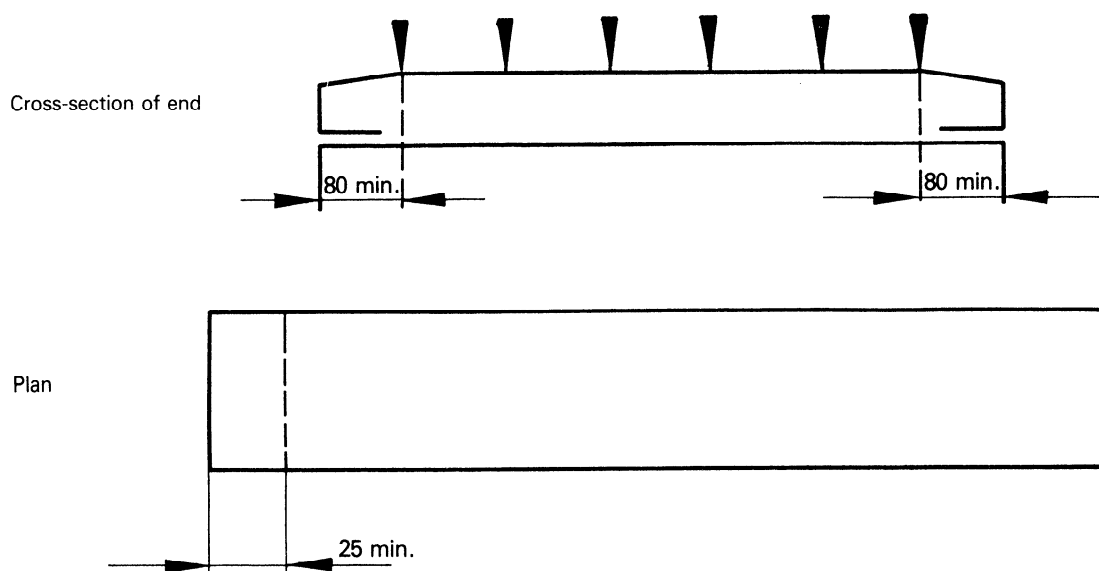

Figure 7 – Measurement of thickness

7.4 Measurement of taper profile

7.4.1 Taper width

Measure the taper profile on each edge 300 mm from the end of each board (five samples). Determine the taper width to an accuracy of ± 2 mm by applying a steel rule to the face of the wallboard near the edge parallel to the end, as shown in figure 8.

Record the distance between the edge and the point where the rule touches the face of the board as the taper width.

7.4.2 Taper depth

Measure the taper depth using a micrometer mounted on a special measuring device as shown in figure 9.

The micrometer shall be accurate to $\pm 0,01$ mm.

Perform the measurement as follows.

Put the measuring device on the face of the board, with the micrometer 150 mm from the edge, and adjust the scale of the meter to zero. Move the device towards the edge and take the reading 10 mm from the edge.

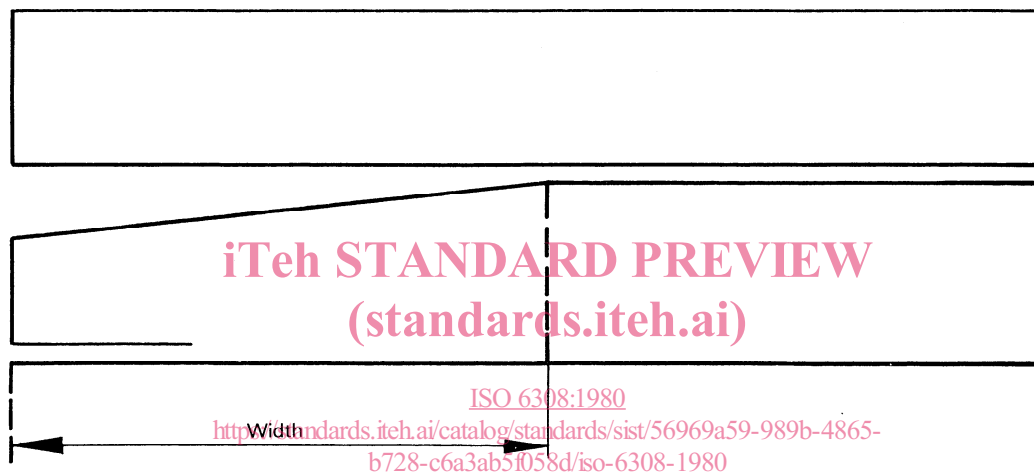

Figure 8 – Measurement of taper width

Dimensions in millimetres

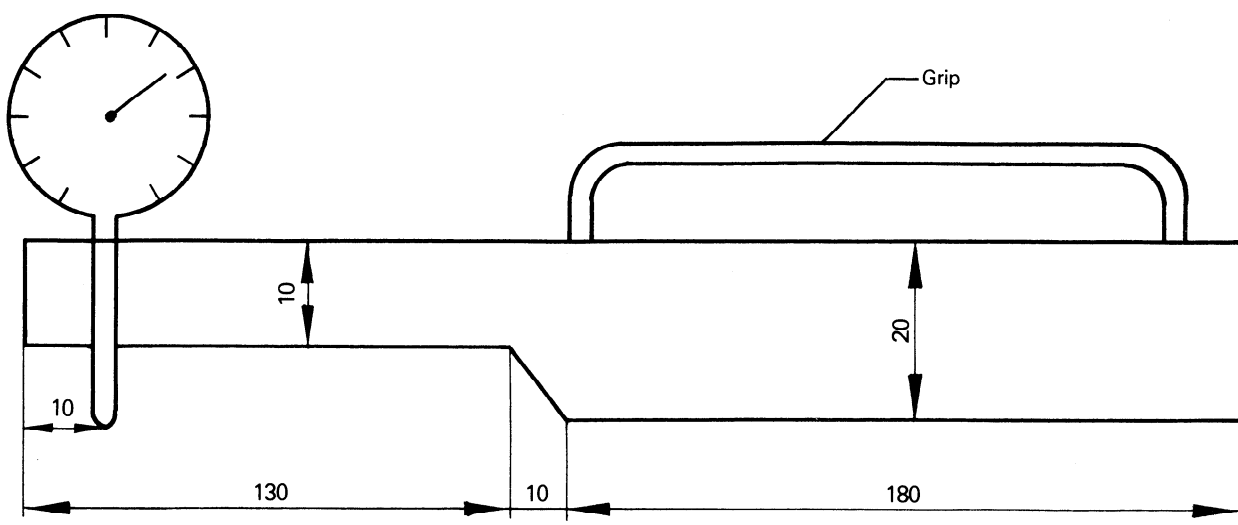

Figure 9 – Measurement of taper depth

7.5 Measurement of breaking load

Cut two specimens, $400 \pm 1,5$ mm by $300 \pm 1,5$ mm with all edges square, from each of five boards, one specimen being taken in the longitudinal direction and the other in the transverse direction. Cut the specimens at least 100 mm away from the ends and edges of the board, except in the case of 400 mm wide board where it is impossible to do so.

Dry the samples to constant mass at 40 ± 2 °C, and test immediately.

Support each specimen simply, face downwards in the case of

longitudinal specimens and face upwards in the case of transverse specimens, on parallel supports, rounded to a radius of between 3 and 10 mm, spaced at 350 mm centres. Apply the load, at a rate of 250 N/min ± 20 % at the centre of the span along the line parallel with the end supports, through a bearing rounded to a radius of between 3 and 10 mm.

Record the average failing load of the five longitudinal specimens and the average for the five transverse specimens, together with the minimum individual result in each direction.

NOTE — Information on the relationship between breaking load at constant span and at constant slenderness ratio is given in the annex.

iTeh STANDARD PREVIEW (standards.iteh.ai)

ISO 6308:1980

<https://standards.iteh.ai/catalog/standards/sist/56969a59-989b-4865-b728-c6a3ab5f058d/iso-6308-1980>