

---

# International Standard



# 6313

---

INTERNATIONAL ORGANIZATION FOR STANDARDIZATION • МЕЖДУНАРОДНАЯ ОРГАНИЗАЦИЯ ПО СТАНДАРТИЗАЦИИ • ORGANISATION INTERNATIONALE DE NORMALISATION

---

## Road vehicles — Brake linings — Effects of heat on dimensions and form of disc brake pads — Test procedure

*Véhicules routiers — Garnitures de freins — Effets de la chaleur sur les dimensions et la forme des patins de freins à disque — Méthode d'essai*

First edition — 1980-06-01

**iTeh STANDARD PREVIEW**  
**(standards.iteh.ai)**

[ISO 6313:1980](#)

<https://standards.iteh.ai/catalog/standards/sist/68b21584-1316-4587-87c8-ba3ce5422f3/iso-6313-1980>

---

UDC 621.113-597.2 : 620.1 : 536.4

Ref. No. ISO 6313-1980 (E)

**Descriptors** : road vehicles, brake linings, brake shoes, disk brakes, tests, dimensional stability tests, heating tests, test equipment.

## Foreword

ISO (the International Organization for Standardization) is a worldwide federation of national standards institutes (ISO member bodies). The work of developing International Standards is carried out through ISO technical committees. Every member body interested in a subject for which a technical committee has been set up has the right to be represented on that committee. International organizations, governmental and non-governmental, in liaison with ISO, also take part in the work.

Draft International Standards adopted by the technical committees are circulated to the member bodies for approval before their acceptance as International Standards by the ISO Council.

International Standard ISO 6313 was developed by Technical Committee ISO/TC 22, *Road vehicles*, and was circulated to the member bodies in November 1978.

It has been approved by the member bodies of the following countries :

Austria	Ireland	Spain
Belgium	Italy	Sweden
Brazil	Japan	Switzerland
Bulgaria	Korea, Dem. P. Rep. of	Turkey
Czechoslovakia	Mexico	United Kingdom
Denmark	Netherlands	USA
France	Poland	USSR
Germany, F. R.	Romania	Yugoslavia
India	South Africa, Rep. of	

No member body expressed disapproval of the document.

# Road vehicles — Brake linings — Effects of heat on dimensions and form of disc brake pads — Test procedure

## 0 Introduction

This International Standard describes a method for measuring dimensional changes of disc brake pads under the influence of heat. At the same time, it gives an indication of the resistance of whole disc brake pads to heat transfer in the direction of applied pressures. According to the design of the test rig, either one or two disc brake pads are required for testing. An extension of this International Standard for drum brake linings has still to be prepared.

Dimensional changes and the temperatures recorded in accordance with this test method in the zone of contact of the operating forces are measured on disc brake pads whose rubbing surface is pressed against a heated plate subjected to a given temperature-time programme.

## 1 Scope and field of application

This International Standard specifies a combined method of measuring disc brake pads to determine their dimensional changes in relation to temperature and their resistance to heat transfer.

The dimensions concerned are :

- thickness dimension;
- certain dimensions of the lining outline when their variation may involve a malfunctioning of the brake.

This International Standard applies to disc brake pads for road vehicles. Their dimensions should not exceed 80 mm in depth, 120 mm in width and 20 mm in thickness, being of integral moulded or bonded type, and the backing plate of solid type.

## 2 Reference

ISO 611, *Braking of motor vehicles and their trailers — Terminology*.

## 3 Symbols and designations

For general definitions, see ISO 611.

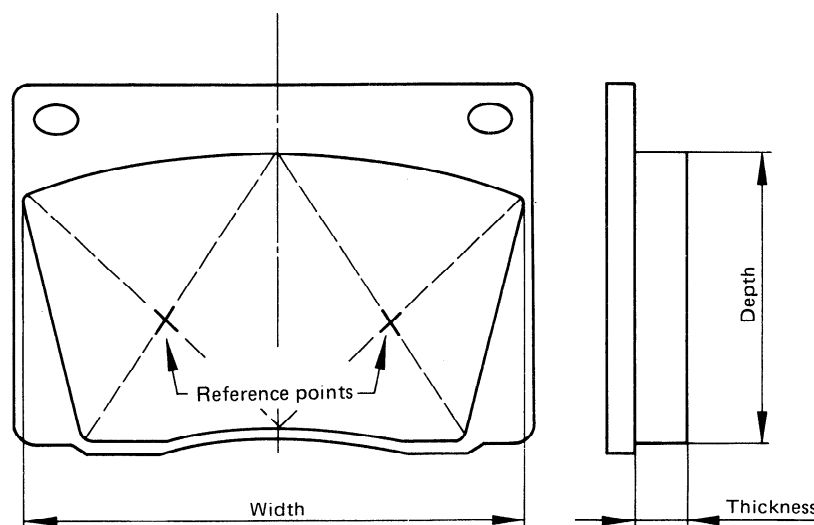

Figure 1 — Principal dimensions and determination of reference points

Symbol	Designation
$d_m$	Mean thickness of specimen pad (see clause 4)
$d_{Ai}$	Dimensions, possibly concerned, of the lining outline (see clause 4)
$d_{Bi}$	Dimensions, possibly concerned, of the lining outline at ambient temperature after test (see clause 6)
$\Delta d_i$	Changes of the possibly concerned dimensions of the lining outline (see clause 7)

#### 4 Sampling and conditioning

Take the samples from stock.

Before placing the pads into the test rig, rub them down on both sides with emery paper (grain size No. 120) so as to remove the coat of paint from the backing plate and to render the rubbing surface itself smooth and free from unevenness.

Remove any friction material from spigot holes in the backing plate to a depth sufficient to avoid influencing the test results.

In the case of disc brake pads fitted with a thin flexible anti-noise strip on the back face of the backing plate, prepare this strip in the same way as the friction material to give a good contact surface.

Determine two reference points as shown in figure 1, and measure the thickness of the disc brake pad at the reference points to an accuracy of 0,01 mm. The mean value of these two measurements is designated  $d_m$ .

Measure the dimensions, if concerned, of the lining outline. These values are designated  $d_{Ai}$ .

Drill a 2 mm diameter hole in the side of the lining down to one of the reference points described above. This hole shall be parallel to the rubbing surface at a distance of 5 mm, and is used to house a sheathed thermocouple.

Drill a 2 mm diameter hole in the lining backing plate parallel to and same depth as the hole described above, to house a sheathed thermocouple. In the case of disc brake pads equipped with anti-noise strips, this hole is omitted.

Linings exceeding the limits of 120 × 80 × 20 mm shall be reduced to this size by cutting with a parting-off disc and/or by surface grinding.

#### 5 Test rig

**5.1** The test rig is composed of a rigid, electrically heated steel plate, 80 mm high, 170 mm wide and 40 mm thick, with devices for clamping the brake pad and for the measuring equipment.

The test rig may be designed for two brake pads.

As an example, figure 2 shows a test rig, which meets the requirements.

The rig consists of (see figure 2) :

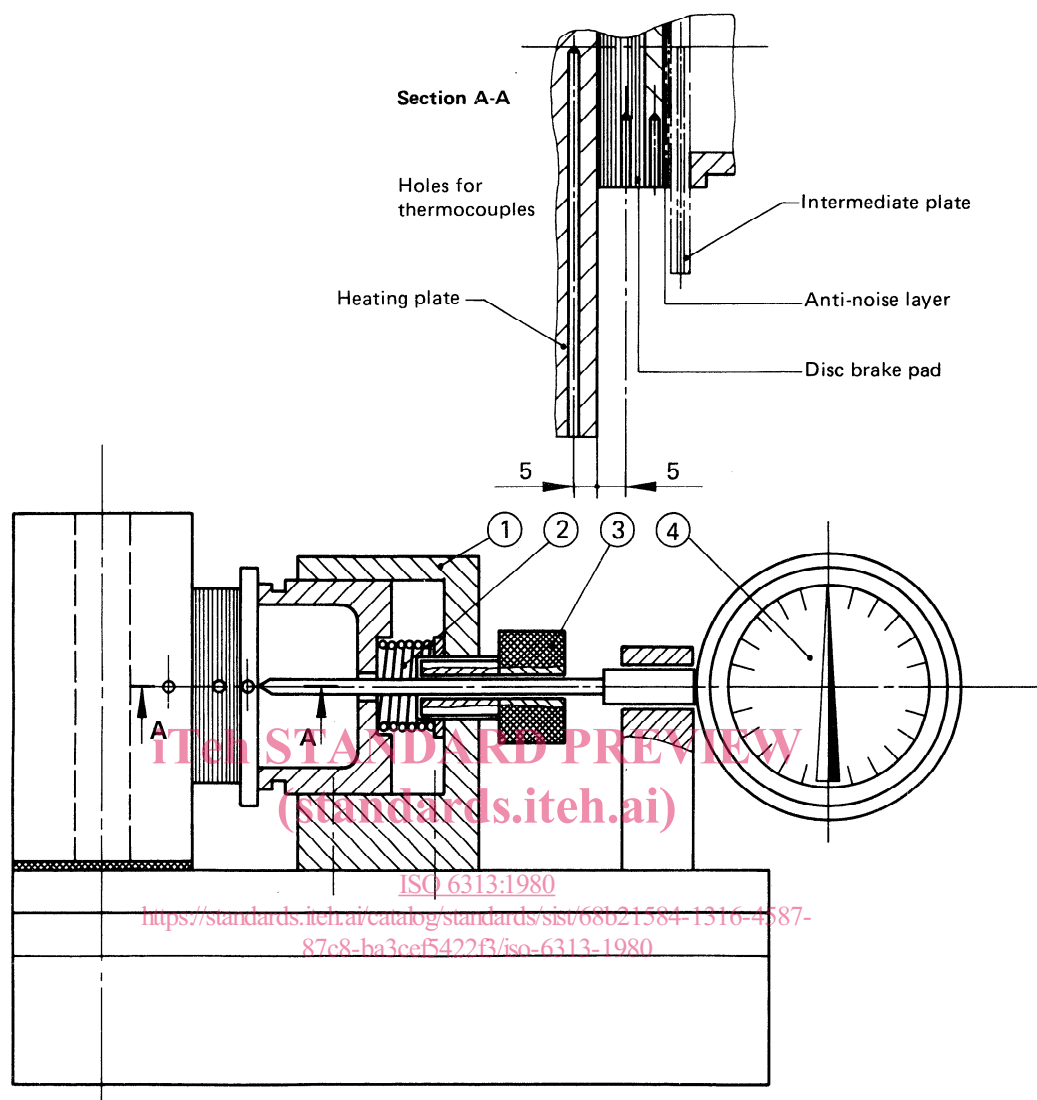

Figure 2 — Example of test rig

- a) a clamping block (1) provided with a piston of 48 mm diameter moving easily in the block;
- b) various coil springs (2) ensuring by deflection the force through the piston;
- c) a screw thread with adjuster nut (3) to deflect the springs;
- d) a dial gauge (4) measuring displacement from the pad backing plate or intermediate plate through the device ensuring the compressive force.

## 5.2 Heating capacity

The heating source shall be capable of bringing the plate to a temperature of 400 °C in  $10 \pm 0,5$  min. In certain cases, especially with a view to utilization of tested brake linings on a given vehicle type, it may be necessary to adopt a plate tempe-

rature above 400 °C and to reach this temperature in less than 10 min.

## 5.3 Measuring equipment

Temperature is measured centrally in the heating plate by means of a sheathed thermocouple in a hole running parallel to, and 5 mm from, the contact surface (see figure 2).

In the case of disc brake pads equipped with anti-noise strips, a 4 mm thick 80 × 100 mm thermal conductive plate is placed between the pad and the clamping device for the measurement of heat transfer. The temperature measurement on this plate is taken by means of a sheathed thermocouple which is situated in a hole drilled to the centre of the plate (see figure 2).

The block for clamping the disc brake pad is provided with a device capable of applying a force range of 20 to 200 N. Fixed on the same side the displacement measuring devices shall measure the displacement from the pad backing plate or intermediate plate.

## 6 Test method

Place the disc brake pad prepared in accordance with clause 4 between the heater plate and clamping block, with the rubbing surface towards the heater plate, and clamped with a pad surface pressure of about 20 kPa (0,02 N/mm<sup>2</sup>).

In the case of disc pads equipped with anti-noise strips, insert the intermediate plate between the pad and the clamping block. The dial gauges or inductive displacement transducers are mounted and set to zero.

Switch on the heating at a setting which will result in a final temperature of 400 °C at the end of a 10 min heating period.

NOTE — In certain cases, especially with a view to utilization of tested brake linings on a given vehicle type it may be necessary that this final temperature be above 400 °C and reached in less than 10 min.

According to the equipment used, measure the variations in the pad thickness and the temperature of the heating plate, the friction material and the pad backing plate or intermediate plate during the heating and cooling period.

If the measurements are not taken by means of a recorder, these shall be read at 25 °C intervals of heater plate temperature between 50 °C and the final temperature.

After the final temperature has been reached, the heat source is switched off, and the cooling period begins during which the system is allowed to cool naturally, without any cooling air blown on to the heater plate.

As soon as the heater plate reaches 50 °C, switch the heat source on again and repeat the process described above. No readjustment shall take place under any circumstances at the beginning of the second heating period.

At the end of the test, measure the dimensions, if concerned, of the lining outline at room temperature. These values shall be designated  $d_{Bi}$ .

## 7 Presentation of results

7.1 If a recorder is used, the traces shall be suitably identified so that the recording of change of pad thickness, heater plate

temperature, pad temperature and pad backing plate or intermediate plate temperature can be unambiguously related to the appropriate factors. If an  $x, y^1, y^2, y^3$  plotter is used, the direction of the abscissae is controlled by the heater plate temperature.

7.2 If the values are read off, pad and pad backing plate or intermediate plate temperature and change of lining thickness shall be plotted on millimetre paper against heater plate temperature, again making sure that the curves are suitably identified.

Finally, if need be, calculate the differences

$$\Delta d_i = d_{Bi} - d_{Ai}$$

## 8 Test report

The test report shall contain following particulars :

- a) quality designation, type and supplier of the disc brake pad;
- b) mean thickness  $d_m$  at the beginning of the test;
- c) maximum values of relative change of lining thickness with the corresponding temperatures and test period;
- d) change of lining thickness at highest temperature for the first and the second test period;
- e) residual change of thickness and dimensions, if concerned, of the lining outline at the end of the test when cooled down to room temperature;
- f) pad backing plate or intermediate plate temperature at highest heater plate temperature for the first and second test period;
- g) appearance of the disc brake pads after the test, noting especially any formation of cracks and bubbles, peeling or chipping of friction material and detachment from the backing plate.

**iTeh STANDARD PREVIEW**  
**(standards.iteh.ai)**

This page intentionally left blank

[ISO 6313:1980](#)

<https://standards.iteh.ai/catalog/standards/sist/68b21584-1316-4587-87c8-ba3cef5422f3/iso-6313-1980>

**iTeh STANDARD PREVIEW**  
**(standards.iteh.ai)**

This page intentionally left blank

ISO 6313:1980

<https://standards.iteh.ai/catalog/standards/sist/68b21584-1316-4587-87c8-ba3cef5422f3/iso-6313-1980>