



SLOVENSKI STANDARD

SIST EN 1400-1:2003

01-maj-2003

Child use and care articles - Soothers for babies and young children - Part 1: General safety requirements and product information

Child use and care articles - Soothers for babies and young children - Part 1: General safety requirements and product information

Artikel für Säuglinge und Kleinkinder - Schnuller für Säuglinge und Kleinkinder - Teil 1 : Allgemeine Sicherheitstechnische Anforderungen und Produktinformationen

ITeH STANDARD PREVIEW

Articles de puériculture - Sucettes pour nourrissons et jeunes enfants - Partie 1 : Exigences générales et informations relatives au produit

[SIST EN 1400-1:2003](https://standards.iteh.ai/catalog/standards/sist/95d92564-7323-4dfd-870a-a569cc6552c8/sist-en-1400-1-2003)

Ta slovenski standard je istoveten z: EN 1400-1:2002

ICS:

97.190

SIST EN 1400-1:2003

en

iTeh STANDARD PREVIEW
(standards.iteh.ai)

SIST EN 1400-1:2003

<https://standards.iteh.ai/catalog/standards/sist/95d92564-7323-4dfd-870a-a565ecb352c8/sist-en-1400-1-2003>

ICS 97.190

English version

Child use and care articles - Soothers for babies and young children - Part 1: General safety requirements and product information

Articles de puériculture - Sucettes pour nourrissons et jeunes enfants - Partie 1 : Exigences générales et informations relatives au produit

Artikel für Säuglinge und Kleinkinder - Schnuller für Säuglinge und Kleinkinder - Teil 1 : Allgemeine Sicherheitstechnische Anforderungen und Produktinformationen

This European Standard was approved by CEN on 28 July 2002.

CEN members are bound to comply with the CEN/CENELEC Internal Regulations which stipulate the conditions for giving this European Standard the status of a national standard without any alteration. Up-to-date lists and bibliographical references concerning such national standards may be obtained on application to the Management Centre or to any CEN member.

This European Standard exists in three official versions (English, French, German). A version in any other language made by translation under the responsibility of a CEN member into its own language and notified to the Management Centre has the same status as the official versions.

CEN members are the national standards bodies of Austria, Belgium, Czech Republic, Denmark, Finland, France, Germany, Greece, Iceland, Ireland, Italy, Luxembourg, Malta, Netherlands, Norway, Portugal, Spain, Sweden, Switzerland and United Kingdom.



EUROPEAN COMMITTEE FOR STANDARDIZATION
COMITÉ EUROPÉEN DE NORMALISATION
EUROPÄISCHES KOMITEE FÜR NORMUNG

Management Centre: rue de Stassart, 36 B-1050 Brussels

Contents

	page
Foreword.....	3
Introduction	4
1 Scope	5
2 Normative references	5
3 Terms and definitions.....	5
4 Description of a soother.....	6
5 Requirements and test methods	10
5.1 Materials.....	10
5.2 Construction.....	11
6 Consumer packaging	23
7 Product information.....	23
7.1 General.....	23
7.2 Purchase information.....	23
7.3 Instructions for use	23
Annex A (informative) Information for medical devices.....	25
A.1 Resemble a soother but no other function.....	25
A.2 Resemble a soother but having another minor function.....	25
A.3 Resemble a soother but having another major function	25
A.4 Specialised applications.....	25
A.5 Medical devices	26
Bibliography	27

Foreword

This document EN 1400-1:2002 has been prepared by Technical Committee CEN/TC 252 "Child use and care articles", the secretariat of which is held by AFNOR.

This European Standard shall be given the status of a national standard, either by publication of an identical text or by endorsement, at the latest by March 2003, and conflicting national standards shall be withdrawn at the latest by March 2003.

This document has been prepared under a mandate given to CEN by the European Commission and the European Free Trade Association.

This European Standard EN 1400 "Child use and care articles – Soothers for babies and young children" consists of the following parts:

- *Part 1: General safety requirements and product information*
- *Part 2: Mechanical requirements and tests*
- *Part 3: Chemical requirements and tests*

This part of this European Standard contains one annex:

- annex A (informative) Information for medical devices

According to the CEN/CENELEC Internal Regulations, the national standards organizations of the following countries are bound to implement this European Standard: Austria, Belgium, Czech Republic, Denmark, Finland, France, Germany, Greece, Iceland, Ireland, Italy, Luxembourg, Malta, Netherlands, Norway, Portugal, Spain, Sweden, Switzerland and the United Kingdom.

Introduction

Soothers are widely used throughout Europe to satisfy non-nutritive sucking needs and to pacify children.

They are designed to be in the mouths of babies and young children for long periods. Accidents, some of which have been fatal, have occurred in the past and a prime purpose of this standard is to reduce the risk of accidents occurring in the future. It is stressed that this European Standard cannot eliminate all possible risks to babies and young children using such a product and that parental or guardian control is of paramount importance. It is essential that all warnings and instructions specified in this standard are given clearly by the manufacturer, to allow the consumer to ensure that the soother is used correctly and safely.

This European Standard for soothers for babies and young children consists of the following parts:

- *Part 1: General safety requirements and product information*
- *Part 2: Mechanical requirements and tests*
- *Part 3: Chemical requirements and tests*

The complete European Standard harmonises for the first time minimum safety requirements and test methods for soothers. Most of the provisions have been taken from other existing national and European Standards and for these provisions the Technical Committee has relied on previous validation.

It is not permitted to claim compliance with individual parts of this standard. Any claim relates to all published parts.

It is recommended that manufacturers and suppliers operate to EN ISO 9000 series standards for quality management systems.

In addition it is recognised that some organisations require reference testing. A suggested sampling plan and compliance levels for freshly manufactured soothers are provided in Part 2, annex B (informative). This procedure can be used as a voluntary type approval procedure.

It is noted that all plastic components are regulated by the Commission Directive 90/128/EEC relating to plastic materials and articles intended to come into contact with foodstuffs.

NOTE It is also noted that the release of *N*-nitrosamines and *N*-nitrosatable substances from elastomer or rubber teats and soothers is controlled by the provisions of Commission Directive 93/11/EEC.

1 Scope

This part of this European Standard specifies general safety requirements relating to the materials, construction, packaging and labelling of soothers. It includes also requirements relating to the instructions for use.

This European Standard is applicable to products that resemble or function as a soother unless they are being marketed as medical devices.

This European Standard does not apply to products designed for specialist medical applications, e.g., those relating to Pierre-Robin Syndrome or premature babies. These special cases are described in an informative annex (see annex A).

NOTE It is recommended that soothers excluded from the scope of this European Standard should meet those requirements that can be applied.

The standard is not applicable to feeding teats.¹

2 Normative references

This European Standard incorporates, by dated or undated references, provisions from other publications. These normative references are cited at the appropriate places in the text, and the publications are listed hereafter. For dated references, subsequent amendments to or revisions of any of these publications apply to this European Standard only when incorporated in it by amendment or revision. For undated references the latest edition of the publication referred to applies (including amendments).

EN 1400-2, *Child use and care articles - Soothers for babies and young children - Part 2: Mechanical requirements and tests.*

[SIST EN 1400-1:2003](https://standards.iteh.ai/catalog/standards/sist/95492564-7323-4161-870-a565ecb352c8/sist-en-1400-1-2003)

EN 1400-3, *Child use and care articles - Soothers for babies and young children - Part 3: Chemical requirements and tests.*

3 Terms and definitions

For the purposes of this European Standard, the following terms and definitions apply.

3.1

soother

article intended for satisfying the non-nutritive sucking need of children

NOTE Soothers are also known as pacifiers or babies' dummies.

3.2

teat

flexible nipple which is the part of the soother designed to be placed in the mouth

3.3

shield

structure positioned at the rear of the teat to reduce the likelihood of the soother being drawn entirely into the child's mouth

¹ A standard for safety requirements and test methods for drinking equipment is in preparation.

**3.4
ring or knob**

structure positioned adjacent to or on the shield to facilitate handling of the soother

NOTE The ring, knob or cover can be integral with the shield or plug or it can be a separate component that is attached to the shield or plug.

**3.5
plug**

device located within the neck of the teat that secures the teat to the shield

**3.6
cover**

device that prevents open access to the plug

**3.7
ventilation holes**

holes in the shield of a soother which provide an air passage through which a child can breath, should the soother become accidentally lodged in the mouth. The holes also reduce the risk of the soother being sucked into the pharynx through the generation of negative pressure

4 Description of a soother

A soother as shown in Figures 1, 2, 3 and 4 can consist of:

- a) teat (1)
- b) shield (2)
- c) ring (3)
- d) plug (4)
- e) cover (5)
- f) knob (6)

ITeCh STANDARD PREVIEW
(standards.iteh.ai)
SIST EN 1400-1:2003
<https://standards.iteh.ai/catalog/standards/sist/95d92564-7323-4dfd-870a-a565ecb352c8/sist-en-1400-1-2003>

NOTE Similar components are marked with the same number in Figures 1 to 4.

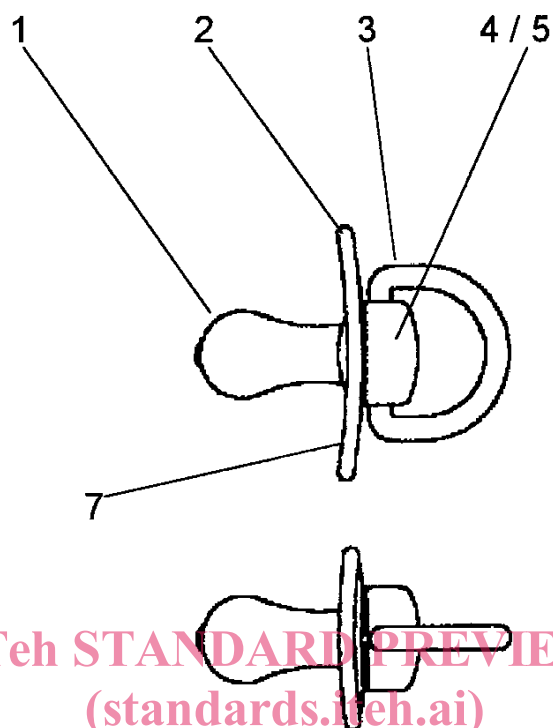

iTeh STANDARD PREVIEW
(standards.iteh.ai)

SIST EN 1400-1:2003

<https://standards.iteh.ai/catalog/standards/sist/95d92564-7323-4dfd-870a-a565ecb352c8/sist-en-1400-1-2003>

Key

- 1 Teat
- 2 Shield
- 3 Ring
- 4 Plug
- 5 Cover
- 7 Sucking face of shield

Figure 1 – Example of a soother with ring

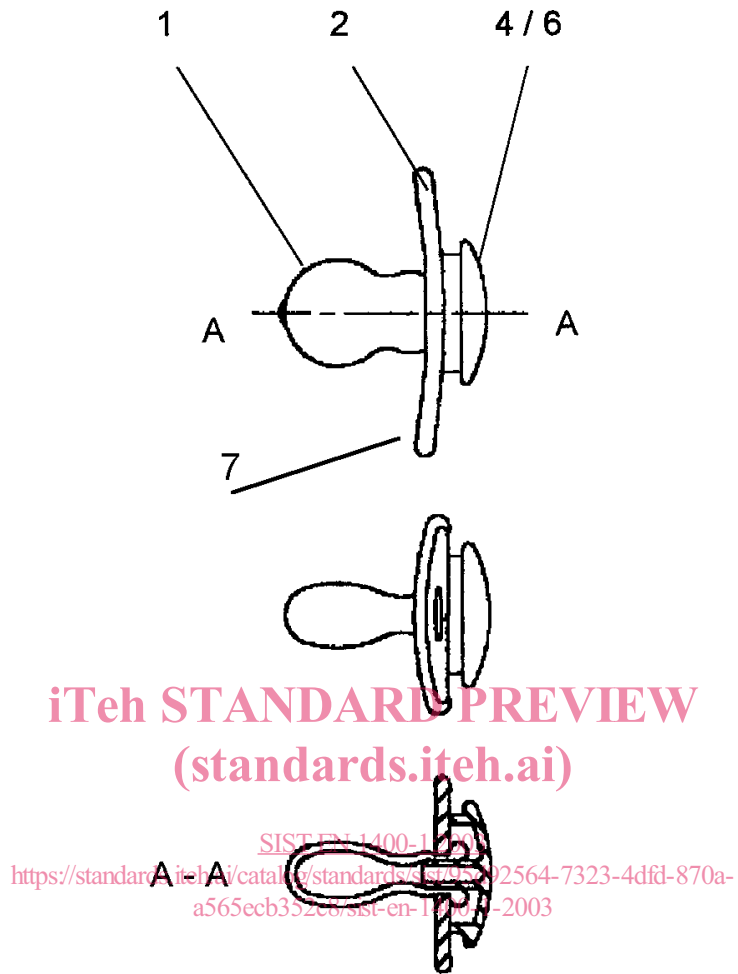

Key

- 1 Teat
- 2 Shield
- 4 Plug
- 6 Knob
- 7 Sucking face of shield

Figure 2 – Example of a soother with knob

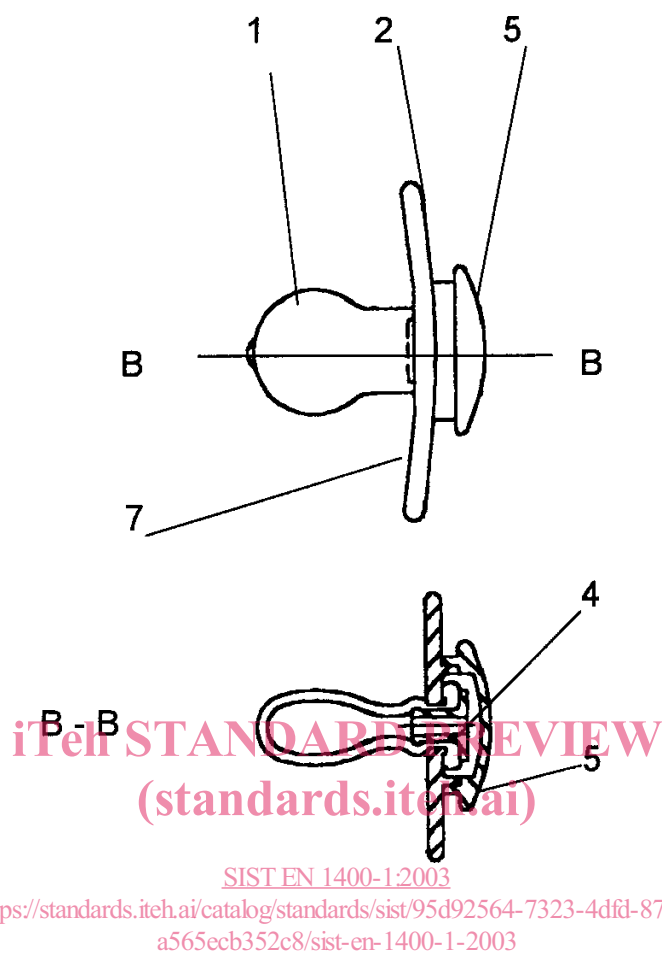
**Key**

- 1 Teat
- 2 Shield
- 4 Plug
- 5 Cover
- 7 Sucking face of shield

Figure 3 – Example of a soother with plug and cover