



SLOVENSKI STANDARD
SIST EN 14350-1:2005
01-januar-2005

Child use and care articles - Drinking equipment - Part 1: General and mechanical requirements and tests

Child use and care articles - Drinking equipment - Part 1: General and mechanical requirements and tests

Artikel für Säuglinge und Kleinkinder - Artikel für flüssige Kindernahrung - Teil 1: Allgemeine und mechanische Anforderungen und Prüfungen

iTeh STANDARD PREVIEW

Articles de puériculture - Articles pour l'alimentation liquide - Partie 1: Exigences générales et mécaniques et essais

[SIST EN 14350-1:2005](https://standards.iteh.ai/catalog/standards/sist/65cbd0c2-fbc5-45ea-b739-7157c6a1c33/sist-en-14350-1-2005)

Ta slovenski standard je istoveten z: EN 14350-1:2004

ICS:

97.190

SIST EN 14350-1:2005

en,fr,de

iTeh STANDARD PREVIEW
(standards.iteh.ai)

SIST EN 14350-1:2005

<https://standards.iteh.ai/catalog/standards/sist/65cbd0c2-fbc5-45ea-b739-4157e6aafc33/sist-en-14350-1-2005>

ICS 97.190

English version

Child use and care articles - Drinking equipment - Part 1:
General and mechanical requirements and tests

Articles de puériculture - Articles pour l'alimentation liquide
- Partie 1: Exigences générales et mécaniques et essais

Artikel für Säuglinge und Kleinkinder - Artikel für flüssige
Kindernahrung - Teil 1: Allgemeine und mechanische
Anforderungen und Prüfungen

This European Standard was approved by CEN on 30 April 2004.

CEN members are bound to comply with the CEN/CENELEC Internal Regulations which stipulate the conditions for giving this European Standard the status of a national standard without any alteration. Up-to-date lists and bibliographical references concerning such national standards may be obtained on application to the Central Secretariat or to any CEN member.

This European Standard exists in three official versions (English, French, German). A version in any other language made by translation under the responsibility of a CEN member into its own language and notified to the Central Secretariat has the same status as the official versions.

CEN members are the national standards bodies of Austria, Belgium, Cyprus, Czech Republic, Denmark, Estonia, Finland, France, Germany, Greece, Hungary, Iceland, Ireland, Italy, Latvia, Lithuania, Luxembourg, Malta, Netherlands, Norway, Poland, Portugal, Slovakia, Slovenia, Spain, Sweden, Switzerland and United Kingdom.

[SIST EN 14350-1:2005](https://standards.iteh.ai/catalog/standards/sist/65cbd0c2-fbc5-45ea-b739-4157e6aafc33/sist-en-14350-1-2005)

<https://standards.iteh.ai/catalog/standards/sist/65cbd0c2-fbc5-45ea-b739-4157e6aafc33/sist-en-14350-1-2005>



EUROPEAN COMMITTEE FOR STANDARDIZATION
COMITÉ EUROPÉEN DE NORMALISATION
EUROPÄISCHES KOMITEE FÜR NORMUNG

Management Centre: rue de Stassart, 36 B-1050 Brussels

Contents

	page
Foreword.....	3
Introduction	4
1 Scope	5
2 Normative references	5
3 Terms and definitions	5
4 Description	6
5 Requirements	10
5.1 General.....	10
5.2 Visual and tactile examination	10
5.3 Small parts.....	10
5.4 Volume	11
5.4.1 Volumetric labelling.....	11
5.4.2 Volumetric accuracy.....	12
5.5 Resistance to tearing	12
5.6 Additional requirements for re-usable products	12
5.6.1 Resistance to boiling water	12
5.6.2 Print adhesion of markings and decorations	12
5.6.3 Thermal shock.....	12
5.7 Additional requirements for sealing discs.....	12
5.8 Requirements for matched components.....	12
5.8.1 Includes protrusions	12
5.8.2 Includes straws	12
5.9 Requirements for protrusions	13
5.10 Requirements for straws.....	13
6 Tests.....	13
6.1 Preparation of samples	13
6.1.1 Re-usable.....	13
6.1.2 Single-use.....	13
6.1.3 Conditioning.....	13
6.2 Order of testing	13
6.3 Tear resistance test	15
6.3.1 Test method.....	15
6.3.2 Tensile test	16
6.4 Volumetric accuracy test	16
6.5 Thermal shock test	17
6.6 Template test.....	17
6.7 Security/retention test.....	18
6.7.1 Principle.....	18
6.7.2 Test procedure	18
6.8 Flexibility test.....	19
6.8.1 Principle.....	19
6.8.2 Method	19
7 Consumer packaging	19
8 Product information.....	20
8.1 General.....	20
8.2 Purchase information	20
8.3 Instructions for use	20
Annex A (informative) A-deviations.....	23
Bibliography	24

I T E H STANDARD PREVIEW
 (standards.iteh.ai)

SIST EN 14350-1:2005

[https://standards.iteh.ai/catalog/standards/sist/65cbd0c2-fbc5-45ea-b739-](https://standards.iteh.ai/catalog/standards/sist/65cbd0c2-fbc5-45ea-b739-4157e6aafc33/sist-en-14350-1-2005)

[4157e6aafc33/sist-en-14350-1-2005](https://standards.iteh.ai/catalog/standards/sist/65cbd0c2-fbc5-45ea-b739-4157e6aafc33/sist-en-14350-1-2005)

Foreword

This document EN 14350-1:2004 has been prepared by Technical Committee CEN/TC 252 "Child use and care articles", the secretariat of which is held by AFNOR.

This European Standard shall be given the status of a national standard, either by publication of an identical text or by endorsement, at the latest by February 2005, and conflicting national standards shall be withdrawn at the latest by February 2005.

According to the CEN/CENELEC Internal Regulations, the national standards organizations of the following countries are bound to implement this European Standard: Austria, Belgium, Cyprus, Czech Republic, Denmark, Estonia, Finland, France, Germany, Greece, Hungary, Iceland, Ireland, Italy, Latvia, Lithuania, Luxembourg, Malta, Netherlands, Norway, Poland, Portugal, Slovakia, Slovenia, Spain, Sweden, Switzerland and the United Kingdom.

This European Standard EN 14350 "Child use and care articles – Drinking equipment" consists of the following parts:

- *Part 1: General and mechanical requirements and tests*
- *Part 2: Chemical requirements and tests*

iTeh STANDARD PREVIEW
(standards.iteh.ai)

SIST EN 14350-1:2005

<https://standards.iteh.ai/catalog/standards/sist/65cbd0c2-fbc5-45ea-b739-4157e6aafc33/sist-en-14350-1-2005>

Introduction

This document establishes minimum safety requirements and gives appropriate test methods for children's drinking equipment.

The complete document harmonises for the first time minimum safety requirements and test methods for children's drinking equipment. Some of the provisions have been taken from other existing national and European Standards and for these provisions the Technical Committee has relied on previous validation.

It is not permitted to claim compliance with individual parts of this document. Any claim relates to all published parts.

A significant choking hazard can arise if the component parts of drinking equipment become separated during use. This hazard is addressed in this document by the inclusion of a security test. However, as the fixing of such products to the container is user-dependent, the risk of an accident cannot be completely eliminated. This document sets out labelling requirements stating that parents or carers should not leave children unattended whilst being fed with a product containing a feeding teat or drinking accessory and that children should not be allowed to use feeding teats as a soother.

The Technical Committee considered the possibility of standardizing both the sizes of feeding teats and ranges of flow rates. However, it was decided that the many combinations of container systems in use precluded the standardization of sizes. It is recommended that all container and feeding teat combinations used are matched components.

The provision of meaningful flow rate information is difficult because of several factors including hole diameter, teat thickness, hole shape /type of feed, and also how individual infants suck the teat. Accordingly, it was decided not to include a test for flow rate but to recommend that manufacturers provide information on flow rate and hole size that is appropriate to their particular product. (standards.iteh.ai)

It is recommended that manufacturers and suppliers operate to EN ISO 9001 [1] standard for quality management systems.

<https://standards.iteh.ai/catalog/standards/sist/65cbd0c2-fbc5-45ea-b739-4157e6aafc33/sist-en-14350-1-2005>

1 Scope

This part of this document specifies general and mechanical requirements for materials to be used for the manufacture of:

- Re-usable feeding teats and drinking accessories;
- Re-usable feeding bottles and drinking cups;
- Single-use feeding bottles, feeding teats, feeding bags and drinking accessories, which do not contain fluid when purchased.

It includes test methods for the mechanical safety requirements specified.

It does not apply to drinking equipment designed for medical applications or for use under medical supervision.

This document is not applicable to soothers. Safety requirements and test methods for soothers are specified in EN 1400-1, EN1400-2 and EN 1400-3.

2 Normative references

The following referenced documents are indispensable for the application of this document. For dated references, only the edition cited applies. For undated references, the latest edition of the referenced document (including any amendments) applies.

EN ISO 291, *Plastics - Standard atmospheres for conditioning and testing*

EN ISO 2409, *Paints and varnishes - Cross-cut test (ISO 2409:1992)*

EN ISO 3696, *Water for analytical laboratory use - Specification and test methods (ISO 3696:1987)*.

ISO 188, *Rubber, vulcanized or thermoplastic - Accelerated ageing and heat resistance tests*.

3 Terms and definitions

For the purposes of this document, the following terms and definitions apply.

3.1

feeding teat

substitute mother's nipple that when attached to a container permits a child to obtain fluid by suckling

3.2

drinking accessory

any device other than a feeding teat which permits a child to obtain fluid from a container

EXAMPLE feeding spout

3.2.1

straw

hollow tube drinking accessory through which fluid is sucked

3.3

container

either a feeding bottle, drinking cup or feeding bag

EN 14350-1:2004 (E)

3.3.1

feeding bottle

container which is capable of holding a fluid and incorporates a graduated scale suitable for visual measurement and is intended for feeding a child through a feeding teat or drinking accessory

3.3.2

drinking cup

container other than a feeding bottle or feeding bag capable of holding a fluid intended for feeding a child

3.3.3

feeding bag

bag capable of holding fluid and supported for use by a holder

NOTE Feeding bags are also known as feeding liners

3.4

locking ring

component used to secure a feeding teat or drinking accessory to a container

3.5

sealing disc

component used to create a seal between the container and the locking ring

3.6

protective cover

component to cover a feeding teat or drinking accessory

3.7

matched components

any of the above defined components which are used together whilst feeding a child

3.8

numbered graduations

numbered markings which indicate the volume of fluid within the container

3.9

single-use feeding teat, drinking accessory or container

any item of drinking equipment sold for single-use

3.10

re-usable

component intended to be used again after first use

3.11

protrusions

drinking accessory, feeding teat or spoon, excluding straws

4 Description

Figures 1, 2, 3, 4 and 5 illustrate typical examples of different items of drinking equipment and their design features.

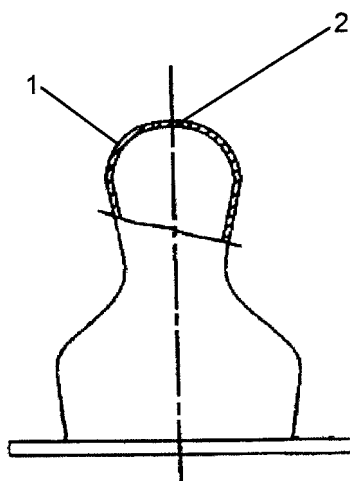

Key

- 1 Nipple
- 2 Feeding Hole/Holes

Figure 1 — Design features of a feeding teat
 (standards.iteh.ai)

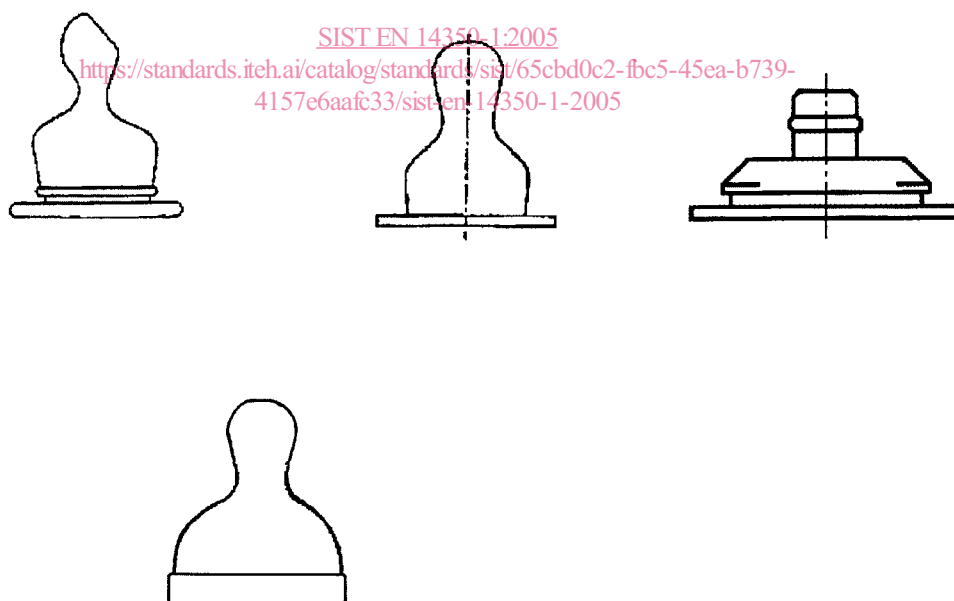
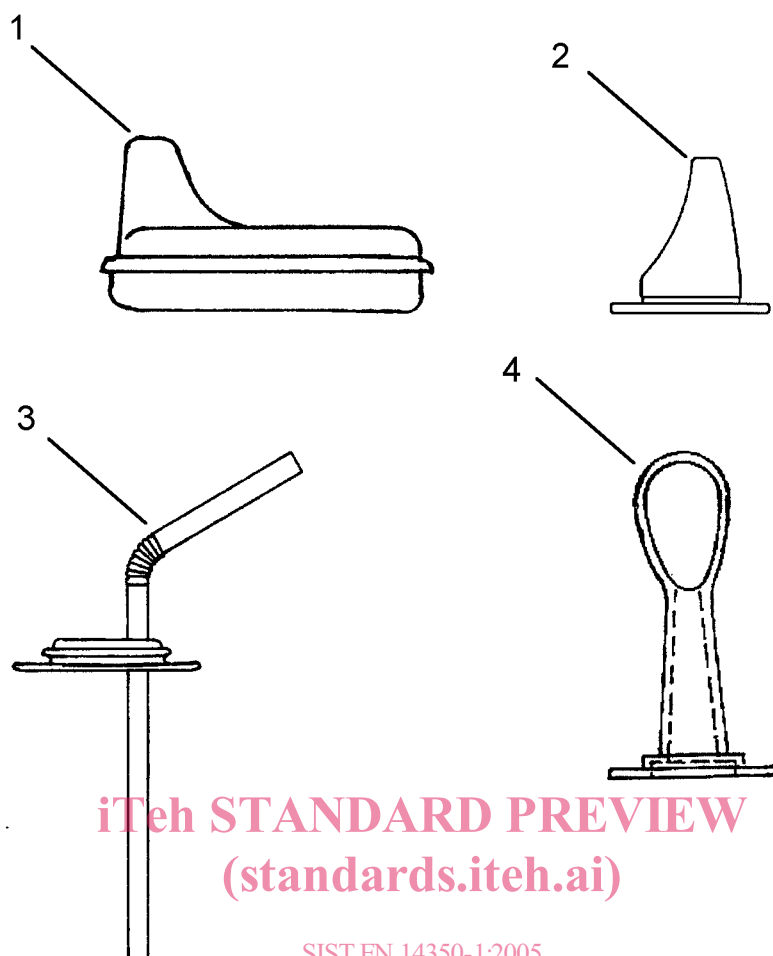

Figure 2 — Examples of feeding teats



iTeh STANDARD PREVIEW
(standards.iteh.ai)

SIST EN 14350-1:2005

<https://standards.iteh.ai/catalog/standards/sist/65cbd0c2-fbc5-45ea-b739-4157e6aafc33/sist-en-14350-1-2005>

Key

- 1 Feeding spout
- 2 Trainer spout
- 3 Straw
- 4 Trainer spoon

Figure 3 — Examples of drinking accessories

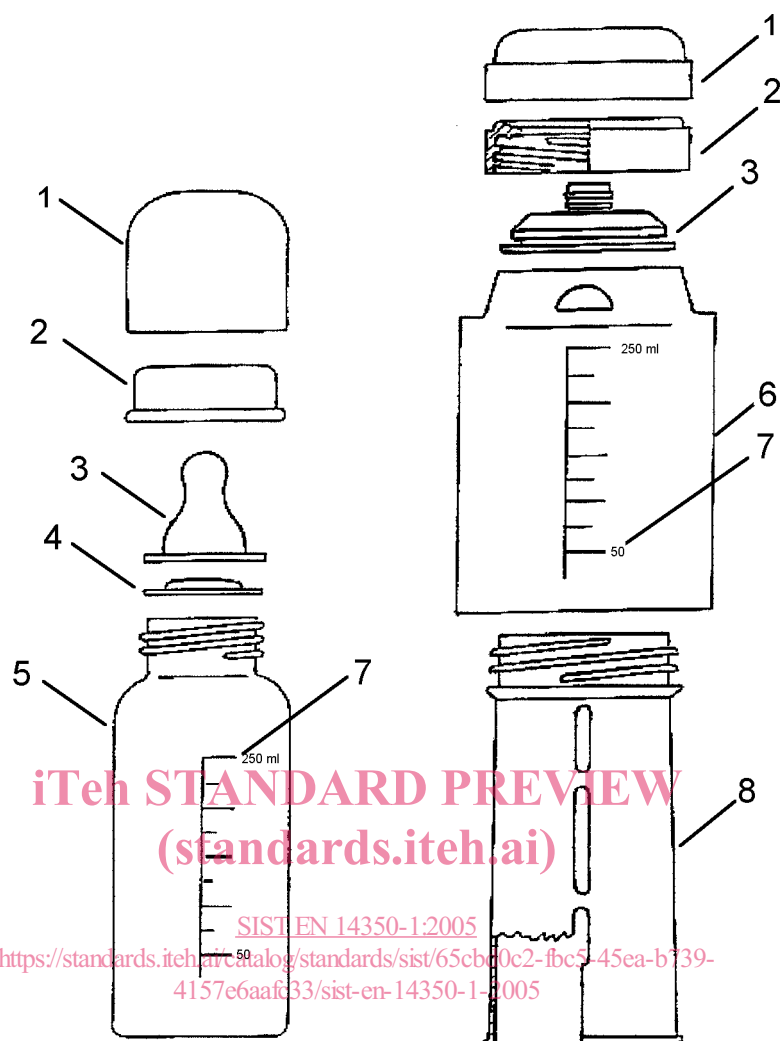

Key

- 1 Protective cover
- 2 Locking ring
- 3 Feeding teat
- 4 Sealing disc
- 5 Feeding bottle
- 6 Feeding bag
- 7 Numbered graduations
- 8 Holder for feeding bag

Figure 4 — Examples of containers with feeding teats