



SLOVENSKI STANDARD

SIST EN 12027:1997

01-avgust-1997

Samolepilni trakovi - Merjenje odpornosti proti plamenu

Self-adhesive tapes - Measurement of flame resistance

Klebebänder - Messung des Brennverhaltens

Rubans auto-adhésifs - Mesure de la résistance à la flamme

Ta slovenski standard je istoveten z: **EN 12027:1996**

[SIST EN 12027:1997](https://standards.iteh.ai/catalog/standards/sist/8a1a507e-4129-42d0-a4b2-731673f8acd2/sist-en-12027-1997)

<https://standards.iteh.ai/catalog/standards/sist/8a1a507e-4129-42d0-a4b2-731673f8acd2/sist-en-12027-1997>

ICS:

13.220.40	Sposobnost vžiga in obnašanje materialov in proizvodov pri gorenju	Ignitability and burning behaviour of materials and products
83.180	Lepila	Adhesives

SIST EN 12027:1997

en

iTeh STANDARD PREVIEW
(standards.iteh.ai)

[SIST EN 12027:1997](https://standards.iteh.ai/catalog/standards/sist/8a1a507e-4129-42d0-a4b2-731673f8acd2/sist-en-12027-1997)

<https://standards.iteh.ai/catalog/standards/sist/8a1a507e-4129-42d0-a4b2-731673f8acd2/sist-en-12027-1997>

EUROPEAN STANDARD

EN 12027

NORME EUROPÉENNE

EUROPÄISCHE NORM

May 1996

ICS 83.180

Descriptors: adhesive tapes, fire tests, flammability testing, fire resistance, flames

English version

**Self adhesive tapes - Measurement of flame
resistance**Rubans auto-adhésifs - Mesure de la résistance
à la flamme

Klebebänder - Messung des Brennverhaltens

ITeH STANDARD PREVIEW
(standards.iteh.ai)SIST EN 12027:1997<https://standards.iteh.ai/catalog/standards/sist/8a1a507e-4129-42d0-a4b2-731673f8acd2/sist-en-12027-1997>

This European Standard was approved by CEN on 1996-04-19. CEN members are bound to comply with the CEN/CENELEC Internal Regulations which stipulate the conditions for giving this European Standard the status of a national standard without any alteration.

Up-to-date lists and bibliographical references concerning such national standards may be obtained on application to the Central Secretariat or to any CEN member.

The European Standards exist in three official versions (English, French, German). A version in any other language made by translation under the responsibility of a CEN member into its own language and notified to the Central Secretariat has the same status as the official versions.

CEN members are the national standards bodies of Austria, Belgium, Denmark, Finland, France, Germany, Greece, Iceland, Ireland, Italy, Luxembourg, Netherlands, Norway, Portugal, Spain, Sweden, Switzerland and United Kingdom.

CENEuropean Committee for Standardization
Comité Européen de Normalisation
Europäisches Komitee für Normung

Central Secretariat: rue de Stassart, 36 B-1050 Brussels

Contents

Foreword..... 3

1 Scope 4

2 Principle 4

3 Apparatus..... 4

4 Test samples and test pieces 4

5 Procedure..... 5

6 Expression of results 5

7 Test report..... 5

iTeh STANDARD PREVIEW
(standards.iteh.ai)

[SIST EN 12027:1997](https://standards.iteh.ai/catalog/standards/sist/8a1a507e-4129-42d0-a4b2-731673f8acd2/sist-en-12027-1997)

<https://standards.iteh.ai/catalog/standards/sist/8a1a507e-4129-42d0-a4b2-731673f8acd2/sist-en-12027-1997>

Foreword

This European Standard has been prepared by the Technical Committee CEN/TC 253 "Self adhesive tapes", the secretariat of which is held by AFNOR.

This European Standard shall be given the status of a national standard, either by publication of an identical text or by endorsement, at the latest by November 1996, and conflicting national standards shall be withdrawn at the latest by November 1996.

According to the CEN/CENELEC Internal Regulations, the national standards organizations of the following countries are bound to implement this European Standard: Austria, Belgium, Denmark, Finland, France, Germany, Greece, Iceland, Ireland, Italy, Luxembourg, Netherlands, Norway, Portugal, Spain, Sweden, Switzerland and the United Kingdom.

iTeh STANDARD PREVIEW
(standards.iteh.ai)

SIST EN 12027:1997

<https://standards.iteh.ai/catalog/standards/sist/8a1a507e-4129-42d0-a4b2-731673f8acd2/sist-en-12027-1997>

1 Scope

This standard specifies a method to measure the ability of an adhesive tape to withstand exposure to flame.

2 Principle

A freely suspended piece of adhesive tape is ignited by means of a fuse. The flame resistance of the adhesive tape is measured by noting the time taken for the flame to go out and the length of adhesive tape burnt.

3 Apparatus

3.1 Test enclosure (see figure 1)

This shall consist of a hollow metal box 250 mm x 250 mm and 750 mm high.

The box shall be open at the top and shall have twelve holes, each 12 mm in diameter, uniformly spaced along a horizontal line 25 mm from the base.

One vertical side shall be fitted with a sliding glass panel. A detachable clip shall be fixed centrally, 30 mm from the top of the box, parallel to the glass panel, to act as a means of attachment for the test pieces so that it can be suspended vertically and hang freely. The test enclosure will be placed during the test in a draught-free atmosphere.

[SIST EN 12027:1997](https://standards.iteh.ai/catalog/standards/sist/8a1a507e-4129-42d0-a4b2-731673f8acd2/sist-en-12027-1997)

3.2 Fuse

<https://standards.iteh.ai/catalog/standards/sist/8a1a507e-4129-42d0-a4b2-731673f8acd2/sist-en-12027-1997>

This shall consist of untreated and uncoated regenerated cellulose film (60 g/m²). It shall have the shape of an isosceles triangle, base 25 mm, height 30 mm.

3.3 Source of ignition

This shall be a non-oxidising flame 20 mm to 25 mm high produced by a micro-Bunsen burner having a tube of nominal 4 mm internal diameter.

3.4 Stop-watch or other timer.

4 Test samples and test pieces

Use sample rolls at least 25 mm wide.

Discard the 3 outer turns of adhesive tape from the roll before taking test pieces.

Perform the test on 5 test pieces, each 300 mm long and 25 mm wide.

Some adhesive tapes contain a residue of flammable solvent and the effect of this, if any, should be included in the test. For this reason, each test piece should be taken from the roll immediately before the test on that test piece, and the test should be started without delay.

Mark each test piece on the back, 50 mm from one end, in ink or by other suitable means.

5 Procedure

5.1 Attach the fuse apex downwards to the adhesive side of the marked end of the test piece, covering not more than 5 mm of the adhesive tape. The short side of the triangle shall lie parallel to the lower edge of the test piece.

5.2 Fix the other end of the test piece in the clip and mount the assembly in the position provided in the hood in such a way that the adhesive tape can hang freely and vertically.

5.3 Slightly raise the glass panel and bring the micro-burner flame to the lower end of the fuse.

Ignite the fuse and close the sliding panel quickly.

6 Expression of results

Record the behaviour of the adhesive tape as follows :

6.1 If the adhesive tape does not ignite, it should be described as "**non-flammable**".

6.2 If the test piece ignites and the flame goes out before reaching the 50 mm mark, note the median value of the burning time of the 5 test pieces. Record, in addition, the longest length of adhesive tape burnt during the 5 tests and classify it as "**self-extinguishing**".

6.3 If the adhesive tape burns, breaks up, or chars, beyond the 50 mm mark, record the median value of the burning time of the 5 test pieces and classify it as "**non-flame resistant**".

If some of the test pieces give results which would bring them into different classifications, this shall be recorded, and the average value shall be chosen in the most appropriate way.

7 Test report

The test report shall include the following information :

- a) a reference to this European Standard ;
- b) all information necessary to identify the test sample ;
- c) the date of the test ;
- d) the results obtained ;
- e) any operation not specified in this European Standard, which may influence the results.

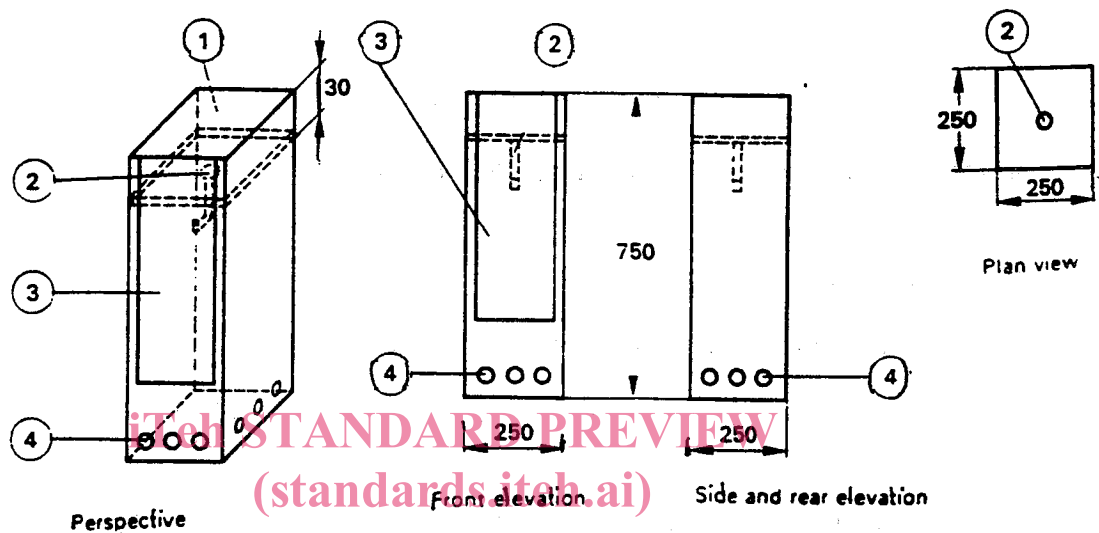

SIST EN 12027:1997

1. Open side. <https://standards.itech.ai/catalog/standards/sist/8a1a507e-4129-42d0-a4b2-731673f8acd2/sist-en-12027-1997>
2. Movable clip placed at the centre 30 mm below the upper edges.
3. Sliding window.
4. 12 mm holes uniformly distributed around the four sides along a horizontal line at a height of 25 mm from the base.

Figure 1 : Test enclosure (Dimensions in millimetres)