



SLOVENSKI STANDARD
SIST EN 1109:2000
01-junij-2000

Hidroizolacijski trakovi - Bitumenski trakovi za tesnjenje streh - Določevanje upogljivosti pri nizki temperaturi

Flexible sheets for waterproofing - Bitumen sheets for roof waterproofing - Determination of flexibility at low temperature

Abdichtungsbahnen - Bitumenbahnen für Dachabdichtungen - Bestimmung des Kaltbiegeverhaltens

Feuilles souples d'étanchéité - Feuilles d'étanchéité de toiture bitumineuses - Détermination de la souplesse a basse température

<https://standards.iteh.ai/catalog/standards/sist/b57db419-2a85-4e6b-86fc-06928f8fa08c/sist-en-1109-2000>

Ta slovenski standard je istoveten z: EN 1109:1999

ICS:

91.060.20	Strehe	Roofs
91.100.50	Veziva. Tesnilni materiali	Binders. Sealing materials

SIST EN 1109:2000 en

iTeh STANDARD PREVIEW
(standards.iteh.ai)

SIST EN 1109:2000

<https://standards.iteh.ai/catalog/standards/sist/b57db419-2a85-4e6b-86fc-06928f8fa08c/sist-en-1109-2000>

EUROPEAN STANDARD

EN 1109

NORME EUROPÉENNE

EUROPÄISCHE NORM

August 1999

ICS 91.100.50

English version

Flexible sheets for waterproofing - Bitumen sheets for roof waterproofing - Determination of flexibility at low temperature

Feuilles souples d'étanchéité - Feuilles d'étanchéité de toiture bitumineuses - Détermination de la souplesse à basse température

Abdichtungsbahnen - Bitumenbahnen für Dachabdichtungen - Bestimmung des Kaltbiegeverhaltens

This European Standard was approved by CEN on 11 July 1999.

CEN members are bound to comply with the CEN/CENELEC Internal Regulations which stipulate the conditions for giving this European Standard the status of a national standard without any alteration. Up-to-date lists and bibliographical references concerning such national standards may be obtained on application to the Central Secretariat or to any CEN member.

This European Standard exists in three official versions (English, French, German). A version in any other language made by translation under the responsibility of a CEN member into its own language and notified to the Central Secretariat has the same status as the official versions.

CEN members are the national standards bodies of Austria, Belgium, Czech Republic, Denmark, Finland, France, Germany, Greece, Iceland, Ireland, Italy, Luxembourg, Netherlands, Norway, Portugal, Spain, Sweden, Switzerland and United Kingdom.

SIST EN 1109:2000

<https://standards.iteh.ai/catalog/standards/sist/b57db419-2a85-4e6b-86fc-06928f8fa08c/sist-en-1109-2000>



EUROPEAN COMMITTEE FOR STANDARDIZATION
COMITÉ EUROPÉEN DE NORMALISATION
EUROPÄISCHES KOMITEE FÜR NORMUNG

Central Secretariat: rue de Stassart, 36 B-1050 Brussels

Contents	Page
Foreword	3
Introduction.....	3
1 Scope.....	3
2 Normative references.....	3
3 Definitions.....	4
4 Principle.....	4
5 Apparatus	4
6 Sampling.....	5
7 Preparation of test specimens.....	6
8 Procedure	6
8.1 Preparation of apparatus.....	6
8.2 Conditioning of test specimens.....	6
8.3 Flexibility at a specified temperature.....	6
8.4 Determination of cold bending temperature.....	6
9 Recording of results, evaluation and precision of test method.....	7
10 Test report	7

STANDARD PREVIEW
(standards.iteh.ai)

SIST EN 1109:2000

<https://standards.iteh.ai/catalog/standards/sist/b57db419-2a85-4e6b-86fc-06928f8108c/sist-en-1109-2000>

Foreword

This European Standard has been prepared by Technical Committee CEN/TC 254 "Flexible sheets for waterproofing", the secretariat of which is held by BSI.

This European Standard shall be given the status of a national standard, either by publication of an identical text or by endorsement, at the latest by February 2000, and conflicting national standards shall be withdrawn at the latest by September 2001.

According to the CEN/CENELEC Internal Regulations, the national standards organizations of the following countries are bound to implement this European Standard: Austria, Belgium, Czech Republic, Denmark, Finland, France, Germany, Greece, Iceland, Ireland, Italy, Luxembourg, Netherlands, Norway, Portugal, Spain, Sweden, Switzerland and the United Kingdom.

Introduction

This European Standard is intended for the characterisation and/or classification of bitumen sheets as manufactured or supplied before use. The test method relates exclusively to products, or to their components where appropriate, and not to waterproofing membrane systems composed of such products and installed in the works.

This test is intended to be used in conjunction with European Standards on product specification for reinforced and unreinforced bitumen sheets for roofing.

The test for flexibility at a low temperature is intended to determine the susceptibility to cracking of the bituminous coating on a sheet when bent under specified conditions. The test result is dependent on the type of coating, on the thickness of the sheet, type and position of the reinforcement and the behaviour of the surfacing material. The use of the test results directly to compare the performance of coatings in sheets of different composition is strictly limited because of the influence of parameters which have not been quantified. Only the results from sheets with the same composition can be used to compare the performance of the coating directly.

The test primarily serves to characterise bitumen sheets. It can also be used to evaluate the change in the cold bending behaviour during artificial ageing. It is not safe to relate the test results to the actual performance to be expected at low temperatures in service.

1 Scope

This European standard specifies the determination of flexibility of reinforced bitumen sheets at low temperatures. Sheets without reinforcement can also be tested using this standard.

The test is carried out on the upper and lower faces of the sheet either at a predetermined temperature or successively at different temperature steps to determine the cold bending temperature which represents a limiting temperature. Therefore, the test can be used to confirm a minimum cold bending temperature for a product or to determine the specific cold bending temperature for the product e.g. to determine the change of these properties as a result of artificial ageing.

2 Normative references

This European Standard incorporates by dated or undated references provisions from other publications. These normative references are cited at the appropriate places in the text and the publications are listed hereafter. For dated references subsequent amendments to or revisions of any of these publications apply to this European Standard only when incorporated in it by amendment or revision. For undated references, the latest edition of the publication referred to applies.

ISO 5725 : 1986 Precision of test methods - Determination of repeatability and reproducibility for a standard test method by inter-laboratory tests.

3 Definitions

For the purposes of this standard the definitions indicated in 3.1 to 3.3 and in the corresponding European Standards on product specifications apply.

3.1 flexibility: The ability of bitumen sheet test specimens to be bent under specified conditions without cracking.

3.2 cold bending temperature: The lowest temperature at which bitumen sheet test specimens can be bent around a specified mandrel without cracking.

3.3 crack: A fissure in the coating of the bitumen sheet extending to the reinforcement or completely through unreinforced sheets.

4 Principle

The test specimens taken from the test sample are bent at the upper side or under side respectively through an angle of 180 ° in a mechanical bending apparatus immersed in a coolant. After bending, the test specimens are examined for the presence of cracks in the coating.

5 Apparatus

The construction and method of operation of the apparatus are shown in figure 1. The apparatus consists of two non-rotating cylinders ($20 \pm 0,1$) mm in diameter and a cylindrical or semi-cylindrical bending mandrel ($30 \pm 0,1$) mm in diameter capable of moving upwards placed between them. The distance a between the cylinders is adjustable so that the distance between the cylinders and the bending mandrel can be adjusted to the thickness of the sheet.

The whole apparatus is immersed in a thermostatic bath which can be controlled between +20 °C and -40 °C to the nearest 0,5 °C. The coolant used shall be either a mixture of

- monopropylene glycol solution¹⁾ / water (volume ratio 1:1) down to -25 °C or
- below -20 °C a mixture of ethanol/water (volume ratio 2:1)

To check the test temperature, an additional thermometer capable of measuring to 0,5 °C is required; its thermosensor shall be placed in the test medium at the same level as the test specimen.

To position the test specimens in the test liquid so that they are flat and completely immersed for conditioning, suitable removable holding devices shall be used. The holding devices should be capable of taking at least the five test specimens in a series.

For the test, the bending mandrel is raised from below against the test specimen at a speed 360 mm/min so that the test specimen is bent through an angle of 180 ° and the electronic control system shall ensure that the travel speed is maintained at (360 ± 40) mm/min at each phase of the bending process and at each temperature. Cracks are detected by visual inspection without any additional aids by the person carrying out the test. To permit an accurate assessment, the travel path is defined in such a way that the test specimen projects out of the coolant at the end of the procedure. The travel section shall be limited by suitably set limit switches.

¹⁾ Monopropylene glycol = 1,2 propanediol (IUPAC)

Dimensions in millimetres

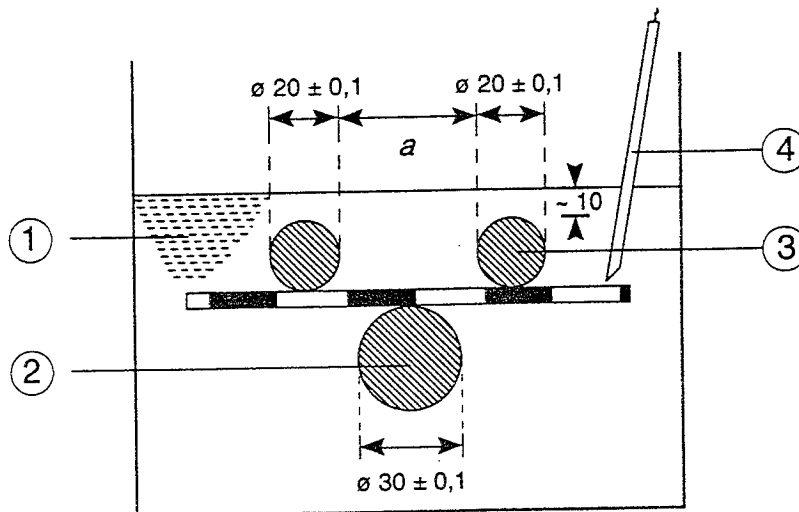

1a) Beginning of bending

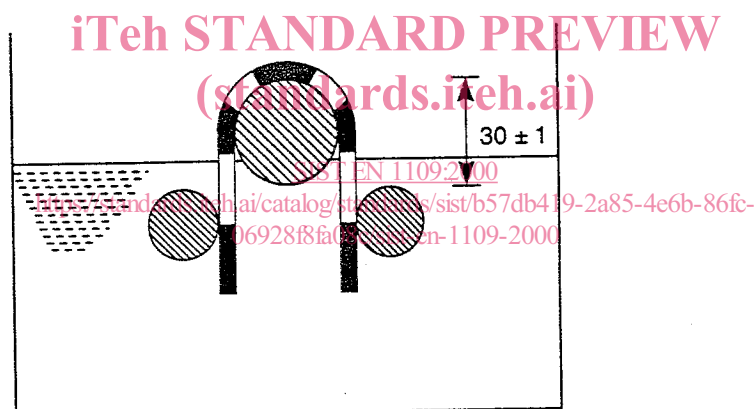

1b) End of bending

Legend: (1) coolant (2) bending mandrel (3) fixed cylinder (4) thermosensor

Figure 1: Principle of test apparatus and bending process

6 Sampling

Test samples shall be taken in accordance with the corresponding European Standard.

Rectangular test specimens with dimensions of (140 ± 1) mm x (50 ± 1) mm as required by the tests described in 8.3 or 8.4 are taken from the test sample uniformly over the width of the sheet and with the larger dimension in the longitudinal direction of the sheet. The test specimens shall not be taken within approximately 150 mm of the edges of the sheet. The test specimens shall be numbered consecutively, beginning from one edge of the sheet, and the upper and lower faces of the sheet shall be marked.

7 Preparation of test specimens

Any protective film shall be removed, preferably by applying a strip of adhesive tape to it at ambient temperature, cooling the test specimen to approximately the presumed cold bending temperature and then pulling the adhesive tape from the test specimen. Alternatively or additionally, the film can be removed by means of a compressed air jet (maximum pressure approximately 5 bar, nozzle diameter approximately 0,5 mm). If it is not possible to remove the film using these methods, a gas flame may be used but for the least time necessary to destroy the film but not otherwise to damage the test specimen.

The test specimens shall then be conditioned prior to the test for at least 4 h at (23 ± 2) °C on a flat support so that they do not touch each other and there can be no adhesive connection with the support. Where necessary a sheet of siliconised paper can be used for this. Loose surface granules shall be removed before by hand by gentle tapping.

8 Procedure

8.1 Preparation of apparatus

Prior to beginning the series of tests, the distance a (see figure 1) between the cylinders shall be adjusted to the thickness of the test specimen so that it is approximately 32 mm plus twice the thickness of the test specimen. The apparatus is then placed in the refrigerant bath so that the top of the cylinders is approximately 10 mm beneath the surface of the coolant. The bending mandrel is then in the bottom position.

8.2 Conditioning of test specimens

After the specified test temperature in the coolant has been reached to the nearest 0,5 °C, the test specimens are inserted into the holding device at the height of the cylinders so that coolant freely circulates around them. The test specimens are conditioned for $1 \text{ h} \pm 5 \text{ min}$ in the coolant from the time when the temperature of the coolant is restored. The thermosensor positioned approximately level with the test specimens is used for checking the temperature of the coolant. Then, the test specimens are tested as described in 8.3 or 8.4.

8.3 Flexibility at a specified temperature

Two series of five test specimens are conditioned as described in 8.2 at the specified test temperature, which is intended to be a whole number. One series are for testing the upper face of the sheet and the other for the lower face. Then they are tested as follows.

The test specimens are placed successively between the bending mandrel and cylinders with the face to be tested uppermost. The bending mandrel is then set in motion pushing upwards against the test specimens at a speed of (360 ± 40) mm/min so that the test specimens are bent uniformly around it. The travel shall stop (30 ± 1) mm above the cylinders (see figure 1). The surface of the test specimens shall be projecting clearly out of the coolant, otherwise the fluid level shall be lowered accordingly.

Within 10 s after the completion of the bending procedure the test specimen is examined under a suitable light source for any cracks using the naked eye and if necessary with additional optical aids. A crack exists if one or more fissures in the coating extend to the reinforcement or completely through unreinforced sheets. All five test specimens in a series are tested immediately after each other. If the dimensions of the apparatus are adequate, simultaneous testing of several test specimens is possible.

8.4 Determination of cold bending temperature

If the cold bending temperature of a bitumen sheet is to be determined (e.g. to show changes resulting from artificial ageing), then the following procedure shall be carried out using the test described in 8.3: