

INTERNATIONAL STANDARD

ISO
6410-2

First edition
1993-05-15

Technical drawings — Screw threads and threaded parts —

Part 2:

Screw thread inserts

iTeh STANDARD PREVIEW

(standards.iteh.ai)

Dessins techniques — Filetages et pièces filetées —

Partie 2: Inserts filetés

<https://standards.iteh.ai/catalog/standards/sist/4da5e818-88be-4a3f-86da-5432acf87695/iso-6410-2-1993>



Reference number
ISO 6410-2:1993(E)

Foreword

ISO (the International Organization for Standardization) is a worldwide federation of national standards bodies (ISO member bodies). The work of preparing International Standards is normally carried out through ISO technical committees. Each member body interested in a subject for which a technical committee has been established has the right to be represented on that committee. International organizations, governmental and non-governmental, in liaison with ISO, also take part in the work. ISO collaborates closely with the International Electrotechnical Commission (IEC) on all matters of electrotechnical standardization.

Draft International Standards adopted by the technical committees are circulated to the member bodies for voting. Publication as an International Standard requires approval by at least 75 % of the member bodies casting a vote.

International Standard ISO 6410-2 was prepared by Technical Committee ISO/TC 10, *Technical drawings, product definition and related documentation*, Sub-Committee SC 6, *Mechanical engineering drawing documentation*.

ISO 6410 consists of the following parts, under the general title *Technical drawings — Screw threads and threaded parts*:

- *Part 1: General conventions*
- *Part 2: Screw thread inserts*
- *Part 3: Simplified representation*

© ISO 1993

All rights reserved. No part of this publication may be reproduced or utilized in any form or by any means, electronic or mechanical, including photocopying and microfilm, without permission in writing from the publisher.

International Organization for Standardization
Case Postale 56 • CH-1211 Genève 20 • Switzerland

Printed in Switzerland

Introduction

ISO 6410 has been devised to provide a universal means of communication among the various interests involved in the design, manufacture and installation of fasteners.

Requirements within industries vary considerably; in recognition of this fact ISO 6410 is presented in three parts (see foreword).

iTeh STANDARD PREVIEW (standards.iteh.ai)

ISO 6410-2:1993

<https://standards.iteh.ai/catalog/standards/sist/4da5e818-88be-4a3f-86da-5432aef87695/iso-6410-2-1993>

iTeh STANDARD PREVIEW
(standards.iteh.ai)

This page intentionally left blank

[ISO 6410-2:1993](#)

<https://standards.iteh.ai/catalog/standards/sist/4da5e818-88be-4a3f-86da-5432aef87695/iso-6410-2-1993>

Technical drawings — Screw threads and threaded parts —

Part 2: Screw thread inserts

1 Scope

This part of ISO 6410 specifies methods for the representation of screw thread inserts on technical drawings.

2 Normative references

The following standards contain provisions which, through reference in this text, constitute provisions of this part of ISO 6410. At the time of publication, the editions indicated were valid. All standards are subject to revision, and parties to agreements based on this part of ISO 6410 are encouraged to investigate the possibility of applying the most recent editions of the standards indicated below. Members of IEC and ISO maintain registers of currently valid International Standards.

ISO 128:1982, *Technical drawings — General principles of presentation*.

ISO 6410-1:1993, *Technical drawings — Screw threads and threaded parts — Part 1: General conventions*.

3 Representation

3.1 Detailed representation of the true shape of screw thread inserts

The detailed representation of the true shape of screw thread inserts (see figures 1 to 3) shall only be used for illustrations, e.g. in catalogues, and should be avoided in technical drawings.

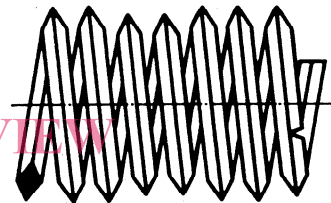

Figure 1

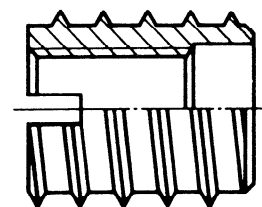

Figure 2

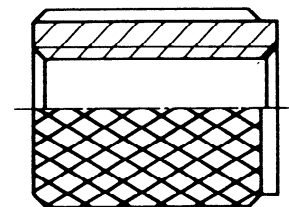

Figure 3

3.2 Conventional representation

Screw thread inserts are usually drawn using a conventional representation derived from ISO 6410-1.

The outer forms of screw thread inserts vary greatly depending on the intended purpose, the material, the manufacturer, etc., and may not even be threaded, but all shall be depicted in the same way. Examples are shown in table 1.

3.3 Simplified representation

In simplified representation only the essential features shall be shown, depending on the kind of drawing and the purpose of the documentation.

The simplified representation for screw thread inserts should be used whenever possible.

The principle of simplification is shown in figure 4. Different examples and possible identification for simplified representation of inserts are shown in table 1.

In sections, the outlines of the screw thread insert (external and internal crests) shall be shown by a continuous thick line (type A, ISO 128). The nominal diameter of the internal thread in assembled condition shall not be shown. The insert itself shall not be hatched (see figure 5).

On an end view, the external and internal crests shall be shown as a full circle by a continuous thick line. The nominal diameter of the internal thread in the assembled condition shall not be shown (see figure 6).

4 Designation and dimensioning

Screw thread inserts shall be designated as given in the relevant International Standards. If such standards are not available the designation shall consist of the designation for the thread, $d \times P$ (screw thread for which the screw thread insert is intended) followed by the letters INS (for insert).

EXAMPLE

M30 × 1,5 INS

When a more general description is sufficient, e.g. there is an insert placed, the abbreviation INS shall be indicated (see figures 5 and 6).

NOTE 1 If the thread is coarse, the designation of the pitch, P , may be omitted.

Additional information (manufacturer's name, catalogue number, etc.) may be added.

The designation may be indicated by means of a leader line (see figure 7) or as a dimension (see table 1).

ISO 6410-2:1993

<https://standards.iteh.ai/catalog/standards/sist/4da5e818-88be-4a3f-86da-5432aef87695/iso-6410-2-1993>

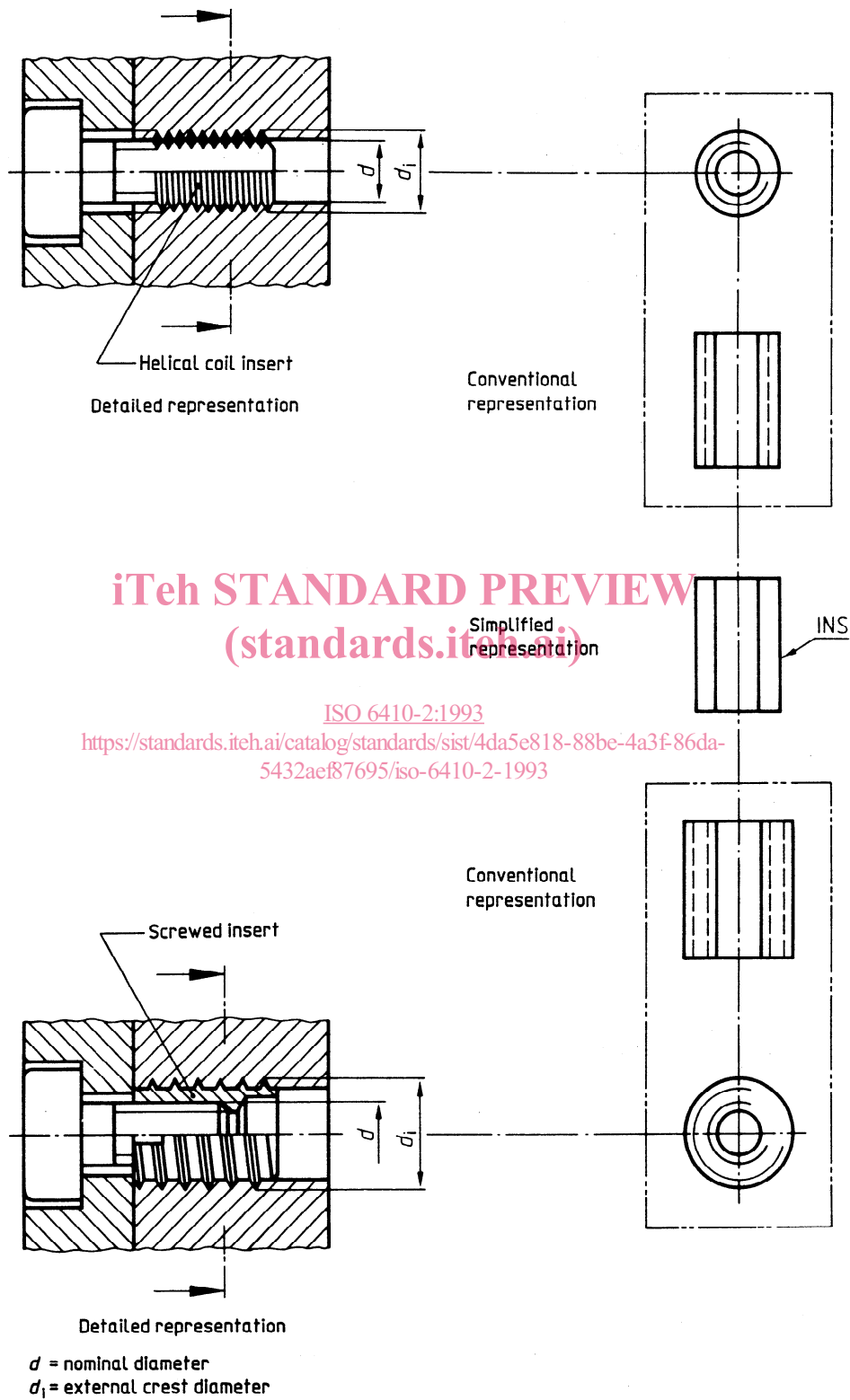

Figure 4

Table 1

	Representation		
	Detailed	Conventional	Simplified
Insert			
Installed insert	in a through hole 		
	in a blind hole 		
Assembly of an insert	in a through hole 		
	in a blind hole 		

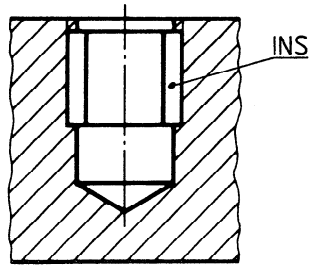

Figure 5

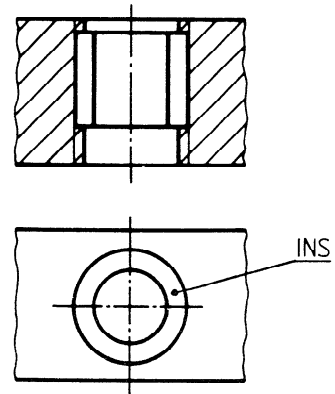

Figure 6

iTeh STANDARD PREVIEW
(standards.iteh.ai)

ISO 6410-2:1993
<https://standards.iteh.ai/catalog/standards/sist/4da5e818-88be-4a3f-86da-5432aef87695/iso-6410-2-1993>

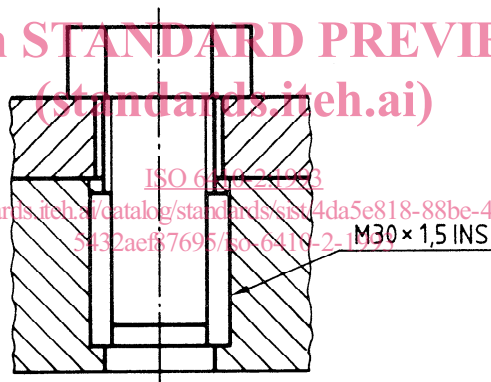

Figure 7