



SLOVENSKI STANDARD
SIST EN 13232-3:2004

01-junij-2004

Številni podatki, ki so potrebni za uporabo tega standarda, so navedeni v prilogi.

Railway applications - Track - Switches and crossings - Part 3: Requirements for wheel/rail interaction

Bahnanwendungen - Oberbau - Weichen und Kreuzungen - Teil 3: Anforderungen an das Zusammenspiel Rad/Schiene

Applications ferroviaires - Voie - Appareils de voie - Partie 3: Exigences pour l'interaction Roue/Rail

<https://standards.iteh.ai/catalog/standards/sist/bd5c43a8-514b-475a-8373-cc94e9f74b74/sist-en-13232-3-2004>

Ta slovenski standard je istoveten z: EN 13232-3:2003

ICS:

45.080 Višje inženirski sistemi za železnice Rails and railway components

SIST EN 13232-3:2004

en

iTeh STANDARD PREVIEW
(standards.iteh.ai)

SIST EN 13232-3:2004

[https://standards.iteh.ai/catalog/standards/sist/bd5c43a8-514b-475a-8373-
ce94e9f74b74/sist-en-13232-3-2004](https://standards.iteh.ai/catalog/standards/sist/bd5c43a8-514b-475a-8373-ce94e9f74b74/sist-en-13232-3-2004)

EUROPEAN STANDARD
NORME EUROPÉENNE
EUROPÄISCHE NORM

EN 13232-3

August 2003

ICS 45.080

English version

Railway applications - Track - Switches and crossings - Part 3: Requirements for wheel/rail interaction

Applications ferroviaires - Voie - Appareils de voie - Partie
3: Exigences pour l'interaction Roue/Rail

Bahnanwendungen - Oberbau - Weichen und Kreuzungen -
Teil 3: Anforderungen an das Zusammenspiel Rad/Schiene

This European Standard was approved by CEN on 13 February 2003.

CEN members are bound to comply with the CEN/CENELEC Internal Regulations which stipulate the conditions for giving this European Standard the status of a national standard without any alteration. Up-to-date lists and bibliographical references concerning such national standards may be obtained on application to the Management Centre or to any CEN member.

This European Standard exists in three official versions (English, French, German). A version in any other language made by translation under the responsibility of a CEN member into its own language and notified to the Management Centre has the same status as the official versions.

CEN members are the national standards bodies of Austria, Belgium, Czech Republic, Denmark, Finland, France, Germany, Greece, Hungary, Iceland, Ireland, Italy, Luxembourg, Malta, Netherlands, Norway, Portugal, Slovakia, Spain, Sweden, Switzerland and United Kingdom.

[SIST EN 13232-3:2004](https://standards.iteh.ai/catalog/standards/sist/bd5c43a8-514b-475a-8373-ce94e9f74b74/sist-en-13232-3-2004)

[https://standards.iteh.ai/catalog/standards/sist/bd5c43a8-514b-475a-8373-
ce94e9f74b74/sist-en-13232-3-2004](https://standards.iteh.ai/catalog/standards/sist/bd5c43a8-514b-475a-8373-ce94e9f74b74/sist-en-13232-3-2004)



EUROPEAN COMMITTEE FOR STANDARDIZATION
COMITÉ EUROPÉEN DE NORMALISATION
EUROPÄISCHES KOMITEE FÜR NORMUNG

Management Centre: rue de Stassart, 36 B-1050 Brussels

Contents

	page
Foreword.....	3
1 Scope	4
2 Normative references	4
3 Introduction	4
3.1 General.....	4
3.2 Wheel and track dimensions	4
3.3 Wheel profiles.....	4
3.4 Wheelsets	5
3.5 Rail and track.....	5
3.6 Tolerances and wear	6
3.7 Contact zone.....	7
3.7.1 Contact profile.....	7
3.7.2 Contact danger zone	7
3.7.3 Flangeway depth.....	7
4 Guidance principles.....	7
4.1 Guard and check Rails	8
4.2 Wheelset guidance	8
4.2.1 Angle of attack	9
4.2.2 Flangeway.....	9
4.2.3 Gauge widening	10
4.2.4 Check rail and common crossing nose	10
4.2.5 Obtuse Crossings	10
4.3 Transitional guidance.....	12
4.4 Entry flares	12
5 Wheel load transfer.....	12
5.1 Sufficiency of bearing area.....	13
5.2 Transfer surfaces.....	15
5.3 Method of assessment	15
6 Insufficient wheel support or guidance.....	15
6.1 Common crossings	15
6.2 Obtuse crossings.....	15
6.3 Movable crossings.....	15
Bibliography	16

Foreword

This document (EN 13232-3:2003) has been prepared by Technical Committee CEN/TC 256 "Railway applications", the secretariat of which is held by DIN.

This European Standard shall be given the status of a national standard, either by publication of an identical text or by endorsement, at the latest by February 2004, and conflicting national standards shall be withdrawn at the latest by February 2004.

This series of European Standards "Railway Applications – Track – Switches and Crossings" covers the design and quality of switches and crossings in flat bottomed rail. The list of parts is as follows:

— *Part 1 : Definitions*

— *Part 2 : Requirements for geometric design*

— *Part 3 : Requirements for wheel/rail interaction*

— *Part 4 : Actuation, locking and detection*

— *Part 5 : Switches*

— *Part 6 : Fixed common and obtuse crossings*

— *Part 7 : Crossings with movable parts*

— *Part 8 : Expansion devices*

— *Part 9 : Layouts*

Part 1 contains terminology used throughout all parts of this series. Parts 2 to 4 contain basic design guides and are applicable to all switch and crossing assemblies. Parts 5 to 8 deal with particular types of equipment, including their tolerances. Part 9 defines the functional and geometric dimensions and tolerances for layout assemblies. These use Parts 1 to 4 as a basis.

The following terms are used within to define the parties involved in using the European Standard as the technical basis for a transaction:

- Customer the Operator or User of the equipment, or the Purchaser of the equipment on the User's behalf;
- Supplier the body responsible for the use of the European Standard in response to the Customer's requirements.

According to the CEN/CENELEC Internal Regulations, the national standards organizations of the following countries are bound to implement this European Standard: Austria, Belgium, Czech Republic, Denmark, Finland, France, Germany, Greece, Hungary, Iceland, Ireland, Italy, Luxembourg, Malta, Netherlands, Norway, Portugal, Slovakia, Spain, Sweden, Switzerland and the United Kingdom.

EN 13232-3:2003 (E)**1 Scope**

This part of this European Standard specifies:

- characterisation of wheel and track dimensions;
- geometric design principles for wheel guidance;
- design principles for wheel load transfer;
- deciding whether movable crossings are needed.

These are illustrated by their application to turnout components:

- switches;
- crossings;
- check rails.

but the principles apply equally to more complex layouts.

2 Normative references **ITeh STANDARD PREVIEW**
(standards.iteh.ai)

Not applicable.

3 Presentation

[SIST EN 13232-3:2004](https://standards.iteh.ai/catalog/standards/sist/bd5c43a8-514b-475a-8373-ce94e9f74b74/sist-en-13232-3-2004)
<https://standards.iteh.ai/catalog/standards/sist/bd5c43a8-514b-475a-8373-ce94e9f74b74/sist-en-13232-3-2004>

3.1 General

The motion of wheels and transfer of wheel loads is a complex subject, involving the accumulation of extensive data and an understanding of dynamic effects.

By making certain assumptions it is feasible to define rules which are simple yet rigorous enough for design of all types of switches and crossings. Some of these rules assume a 2-axle bogie or vehicle. The need for other special requirements such as those posed by 3-axle or other vehicles must be stated by the Customer.

3.2 Wheel and track dimensions

This clause deals with the key dimensions needed for the analysis of the interaction between wheels and the track, either for guidance calculations or load transfer calculations.

Wheel and track dimensions are defined below.

3.3 Wheel profiles

Sufficient dimensions of the cross-section or profile of a wheel are required for switch and crossing design. As a minimum, a dimensioned profile drawing shall be provided by the customer, with the following key dimensions as defined in Figure 1:

- flange width, height and flange angle;
- tyre width and tread angle;
- wheel diameter or radius.

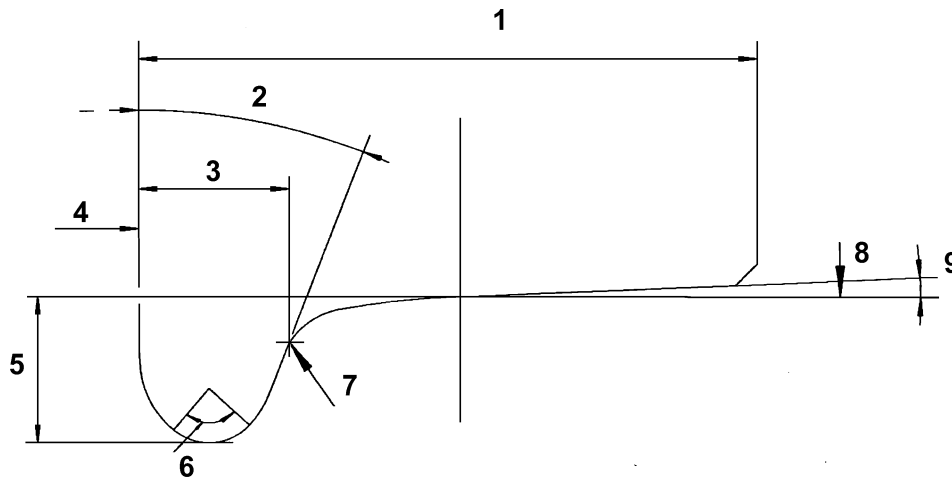

Key

1	Tyre width	6	Danger zone
2	Flange angle	7	Contact point
3	Flange width	8	Wheel diameter
4	Wheel back to back	9	Tread angle
5	Flange depth		

iTeh STANDARD PREVIEW
(standards.iteh.ai)

Figure 1 — Key wheel dimensions (in addition to profile details)

[SIST EN 13232-3:2004](https://standards.iteh.ai/catalog/standards/sist/bd5c43a8-514b-475a-8373-ce94e9f74b74/sist-en-13232-3-2004)

<https://standards.iteh.ai/catalog/standards/sist/bd5c43a8-514b-475a-8373-ce94e9f74b74/sist-en-13232-3-2004>

3.4 Wheelsets

Additional parameters related to the wheelsets are required for calculations for wheelset guidance. The Customer shall provide the following parameter values:

- wheel back-to-back (see Figure 1);
- axle spacing;
- number of axles;
- clearance of middle axles, if applicable;
- bogie spacing and minimum curve radius for vehicles.

3.5 Rail and track

The key parameters related to the track geometry which are used in calculations for wheelset guidance are shown in Figure 2 and listed below:

- centreline radius (R);
- track gauge (G);
- dimension for nose protection (check gauge) (F);
- wing flangeway (D).

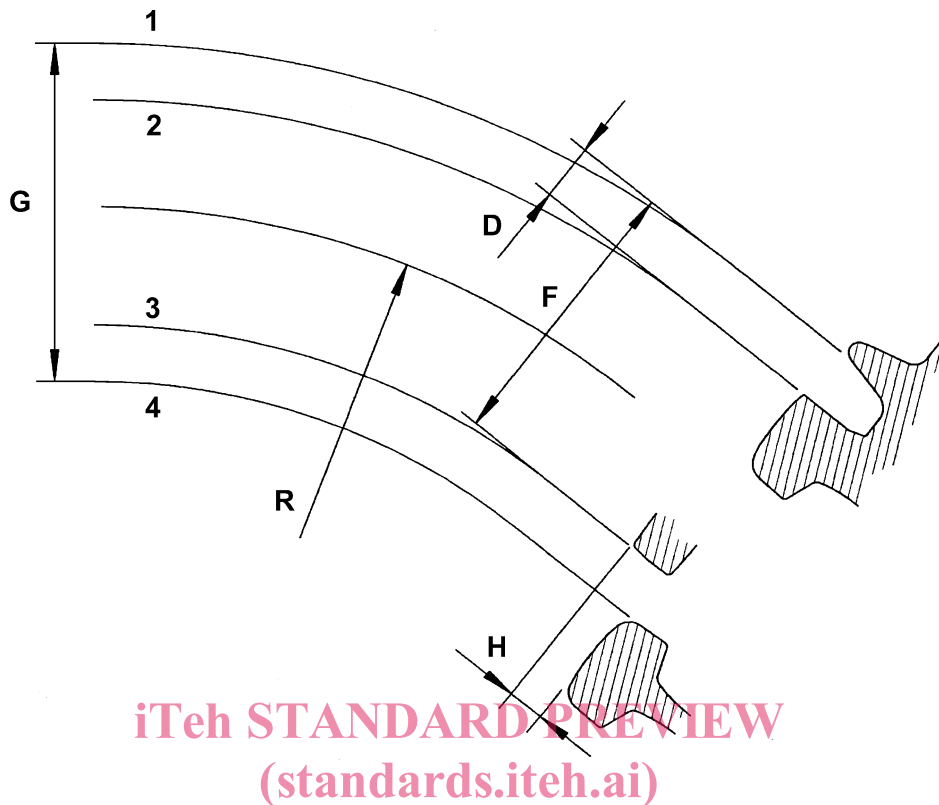

iTeh STANDARD PREVIEW
(standards.iteh.ai)

Key

- 1 Highside
- 2 Wing
- 3 Check
- 4 Lowside

SIST EN 13232-3:2004

<https://standards.iteh.ai/catalog/standards/sist/bd5c43a8-514b-475a-8373-ce94e9f74b74/sist-en-13232-3-2004>

Figure 2 — Key track dimensions

and the following shall be provided by the Customer:

- maximum permissible check rail height above running table (H).

3.6 Tolerances and wear

It is necessary to consider tolerances and wear in order to design correctly. These are alternatively referred to as manufacturing tolerances and service tolerances.

If the Customer provides worn wheel profiles or amounts of wear, then these should be used. Otherwise the assumptions made by the Supplier shall form the basis for design, and these shall be stated. Examples of key areas of wear are:

- back of wheel flanges;
- front of wheel flanges;
- false flanges;
- flange angle.

Locations of typical lateral wheel and track wear are shown in Figure 3. These must be taken into account when designing flangeway gaps. See clause 4.

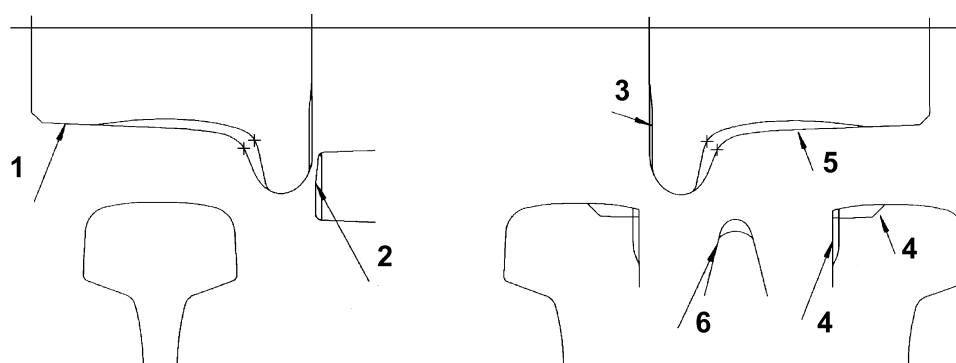

Key

- | | |
|----------------------------|----------------------|
| 1 False flange | 4 Wing wear |
| 2 Guard or check rail wear | 5 Wheel wear (front) |
| 3 Wheel wear (back) | 6 Vee wear |

Figure 3 — Locations of wheel and rail wear

Vertical wear, examples of which are also illustrated in Figure 3, is more relevant to wheel load transfer. See clause 5.

False flanges are to be avoided as they will increase wear as well as the rate of damage to switches and crossings.

3.7 Contact zone

For switch and crossing design, there are issues which shall be verified during design. These are as follows.

3.7.1 Contact profile

The relative radii of wheel and rail shall be taken into account.

3.7.2 Contact danger zone

The wheel profile supplied by the Customer shall indicate the danger zone for guidance contact, which is that part of the wheel flange which falls on the flange radius and which therefore exceeds the angle for safe guidance. The switch and crossing Supplier shall ensure that guidance contact does not take place within this zone for both new and worn wheels, except where it is agreed that flange-running is a normal operating regime.

The danger zone is illustrated in Figure 1.

3.7.3 Flangeway depth

The depth of the flangeway shall be sufficient to prevent flanges from running on the floor of the flangeway except if otherwise required by the Customer. This shall be verified considering the increased depth of flange of a maximum worn wheel and with the shallow flangeway of a maximum worn running surface of a rail.

4 Guidance principles

The guidance of a wheelset through switches and crossings concerns mainly the lateral or horizontal dimensions of wheel, axle, and track. Note that, in Figures 5, 6 and 7, the wheels are shown in a simplified form as ellipses at the gauge reference plane.