

INTERNATIONAL STANDARD

**ISO
6502**

Second edition
1991-05-15

Rubber — Measurement of vulcanization characteristics with rotorless curemeters

iTeh STANDARD PREVIEW
*Caoutchouc. — Détermination des caractéristiques de vulcanisation à
l'aide de rhéomètres sans rotor*
(standards.iteh.ai)

ISO 6502:1991

[https://standards.iteh.ai/catalog/standards/sist/f1a29c8-4927-40a1-b768-
eeb7ace6b3b6/iso-6502-1991](https://standards.iteh.ai/catalog/standards/sist/f1a29c8-4927-40a1-b768-eeb7ace6b3b6/iso-6502-1991)



Reference number
ISO 6502:1991(E)

Foreword

ISO (the International Organization for Standardization) is a worldwide federation of national standards bodies (ISO member bodies). The work of preparing International Standards is normally carried out through ISO technical committees. Each member body interested in a subject for which a technical committee has been established has the right to be represented on that committee. International organizations, governmental and non-governmental, in liaison with ISO, also take part in the work. ISO collaborates closely with the International Electrotechnical Commission (IEC) on all matters of electrotechnical standardization.

Draft International Standards adopted by the technical committees are circulated to the member bodies for voting. Publication as an International Standard requires approval by at least 75% of the member bodies casting a vote.

International Standard ISO 6502 was prepared by Technical Committee ISO/TC 45, *Rubber and rubber products*.

This second edition cancels and replaces the first edition (ISO 6502:1983), of which it constitutes a technical revision.

iTeh STANDARD PREVIEW
(standards.iteh.ai)
ISO 6502:1991
<https://standards.iteh.ai/catalog/standards/sist/f1a29c8-4927-40a1-b768-eeb7ace6b3b6/iso-6502-1991>

© ISO 1991

All rights reserved. No part of this publication may be reproduced or utilized in any form or by any means, electronic or mechanical, including photocopying and microfilm, without permission in writing from the publisher.

International Organization for Standardization
Case Postale 56 • CH-1211 Genève 20 • Switzerland

Printed in Switzerland

Rubber — Measurement of vulcanization characteristics with rotorless curemeters

1 Scope

This International Standard specifies a method for the measurement of selected vulcanization characteristics of rubber compounds using rotorless linear shear and torsion shear curemeters. The two types of instruments may not give the same results.

NOTE 1 An alternative method for the measurement of vulcanization characteristics, using an oscillating disc curemeter, is specified in ISO 3417:1977, *Rubber — Measurement of vulcanization characteristics with the oscillating disc curemeter*. The advantages of rotorless curemeters are that the specified temperature is reached within a shorter time after insertion of the test piece into the die cavity, and that there is better temperature distribution in the test piece.

A method for obtaining comparable results of vulcanization characteristics using oscillating disc and rotorless curemeters is described in 3.6.1, second paragraph.

2 Principle

2.1 A rubber test piece is contained in an almost closed die cavity and maintained at an elevated temperature. The cavity is formed by two dies, one of which is oscillated through a small linear or rotary amplitude. This action produces a sinusoidal alternating linear or torsional strain in the test piece and a sinusoidal shear force or torque which depends on the stiffness (shear modulus) of the rubber compound. The envelope curve, i.e. the amplitude of the oscillating force or torque, is recorded autographically as a function of time (see figure 1).

2.2 The stiffness of the rubber test piece increases as vulcanization proceeds. The curve is complete when the recorded force or torque rises either to an equilibrium value or to a maximum value [see figure 1a)]. The time required to obtain a vulcanization curve is a function of the test temperature and the characteristics of the rubber compound.

2.3 The following measurements can be taken from the recorded curve of force or torque as a function of time, i.e. $F = f(t)$ [see figure 1b)]:

- F_L : minimum force or torque;
- t_{sx} : time to incipient cure [scorch time (see 6.2)];
- $t_c(y)$: time to a percentage, y , of full cure;
- F_t : intermediate force or torque after a specified period of time t ;
- F_{max} : maximum, plateau or highest force or torque attained within a specified period of time, t_e .

The minimum force or torque F_L of a vulcanization curve characterizes the stiffness of the test piece at a specified curing temperature. The scorch time t_{sx} is a measure of the processing safety of the compound. The time $t_c(y)$ and the corresponding forces or torques give information on the progress of cure. The maximum force or torque F_{max} of the vulcanization curve is a measure of the stiffness of the vulcanized rubber at the test temperature.

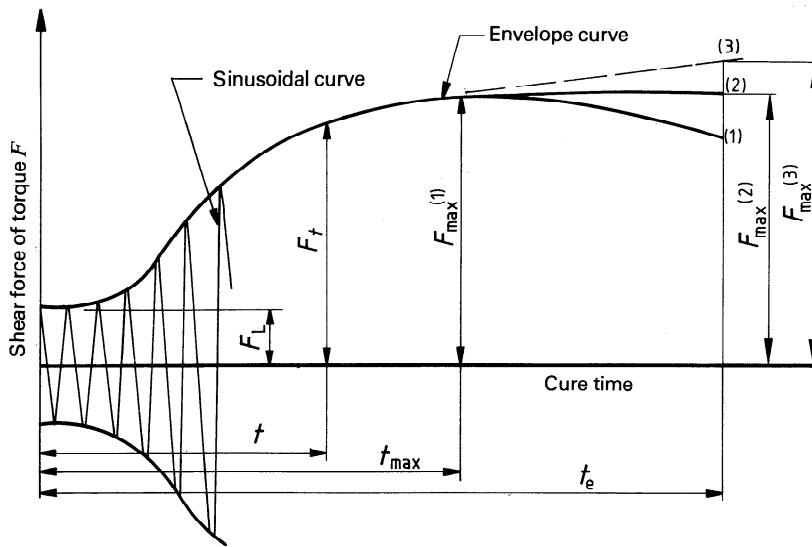

- (1) Vulcanization curve with maximum, $F_{\max}^{(1)}$, at time t_{\max}
- (2) Vulcanisation curve with plateau, $F_{\max}^{(2)}$
- (3) Vulcanization curve with steady increase, $F_{\max}^{(3)}$, at time t_e at the end of test

a) Vulcanization curve $F = f(t)$

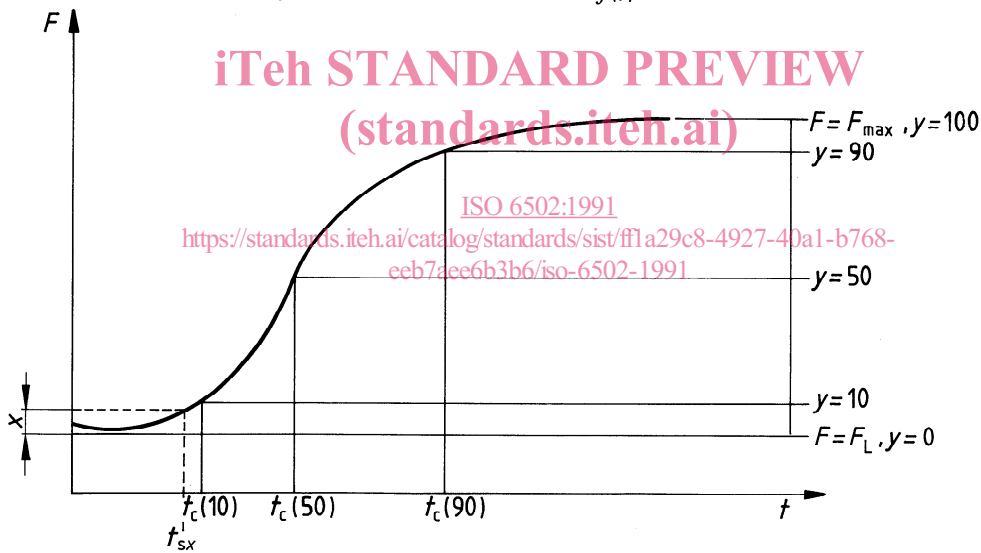

b) Method of evaluation

Figure 1 — Typical vulcanization curve and method of evaluation

3 Apparatus

Rotorless curemeters of two types can be used.

The first type measures the force produced by a linear strain of constant amplitude [see figure 2a)], whilst the second measures the torque produced by an angular strain of constant amplitude [see figure 3a)]. In each case, an oscillation of small amplitude is applied to one die of the almost closed die cavity.

The description and main requirements for the curemeters are as follows.

3.1 Die cavity

The cavity is formed by two dies. In the measuring position, the two dies are fixed a specified distance apart (see 3.2) so that the cavity is almost closed [see figure 2b) and figure 3b)].

The dimensions for typical instruments are: in the case of a linear shear curemeter, a diameter of 30 mm and a height of 4,0 mm; in the case of a torsion shear curemeter, a diameter of 40 mm, an angle of 18° and in the centre 0,5 mm plus die gap, see 3.2 and figure 2b) or figure 3b)].

3.2 Die closure

The dies shall be almost closed during the test by a mechanism capable of exerting a force of not less than 8 000 N. The gap between the dies in the closed position shall be between 0,05 mm and 0,2 mm, preferably 0,1 mm.

3.3 Die oscillating system

The oscillating system consists of a rigid eccentric drive, which imparts a linear to torsional oscillating movement to one of the dies, in the plane of the cavity.

The amplitude of this oscillation shall be either

$\pm 0,01$ mm to $\pm 0,1$ mm, preferably 0,05 mm;

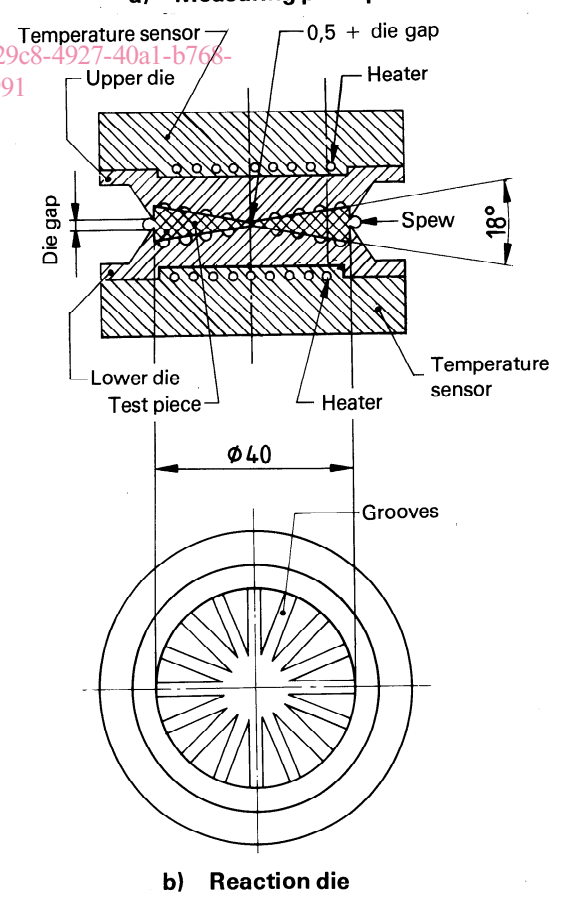
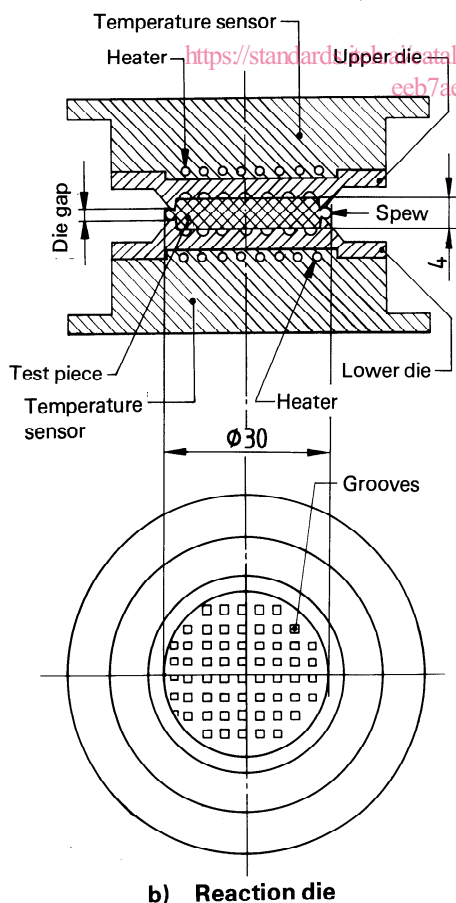
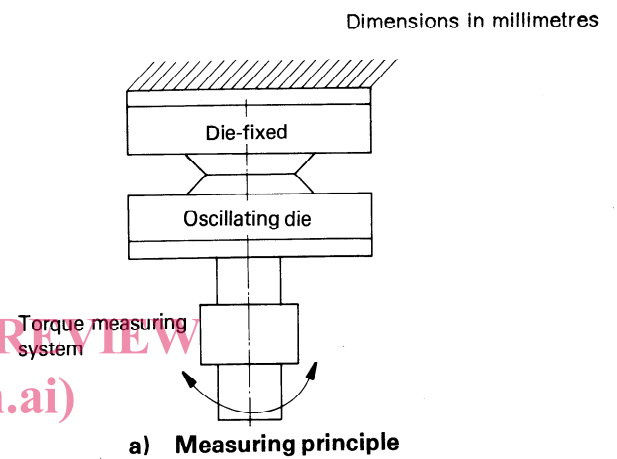
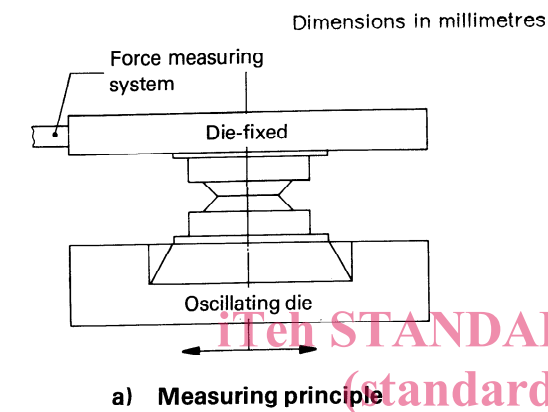

Figure 2 — Typical linear shear curemeter

Figure 3 — Typical torsion shear curemeter

or

$\pm 0,1^\circ$ to $\pm 2^\circ$, preferably $0,5^\circ$.

The frequency shall be between 0,05 Hz and 2 Hz, preferably $1,7 \text{ Hz} \pm 0,1 \text{ Hz}$.

3.4 Force (or torque) measuring system

3.4.1 Measurement

A force (or torque) measuring device shall measure the resultant shear force or torque. It shall be rigidly coupled to one of the dies and any deformation shall be negligibly small and shall generate a signal which is proportional to the force or torque.

The elastic deformation of the oscillating and measuring system should not be more than 1 % of the oscillating amplitude; otherwise, the curemeter curves will have to be corrected.

The total error resulting from zero point error, sensitivity error, linearity and reproducibility errors shall not exceed 1 % of the measuring range selected.

3.4.2 Recording

A recorder shall be used to record the signal from the force (or torque) measuring device. It shall record the envelope [see figure 1a) and figure 1b)] and shall have a response time for full scale deflection on the torque scale of 1 s or less. The force or torque shall be recorded with an accuracy of $\pm 0,5 \%$ of the range.

3.5 Calibration

Calibration equipment is required to measure the linear or angular amplitude and to calibrate the force (or torque) measuring device. Examples of calibration equipment are shown schematically in figure 4 and figure 5.

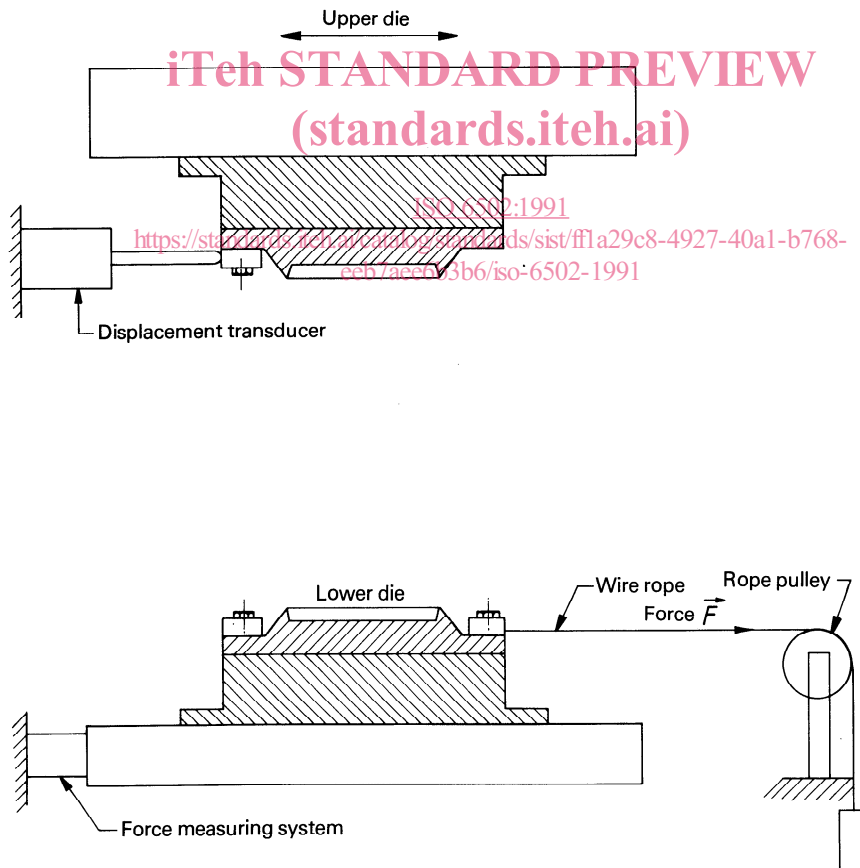

Figure 4 — Calibration equipment for linear shear curemeter

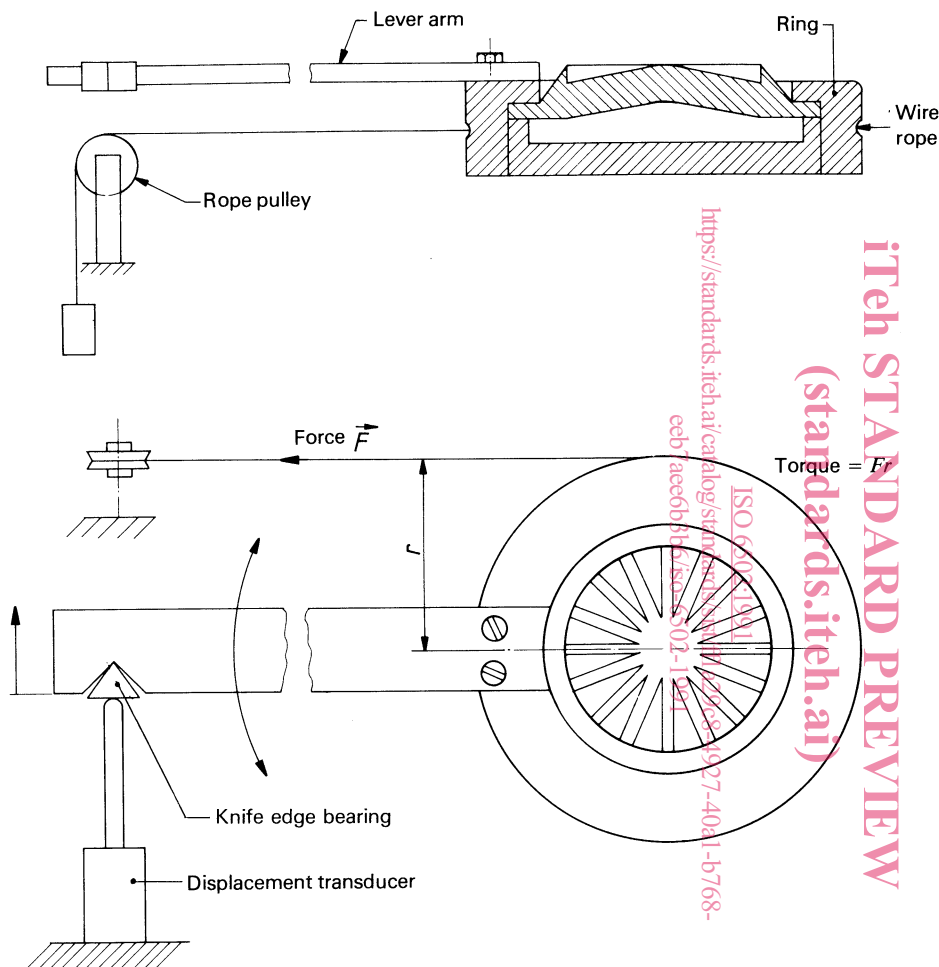

Figure 5 — Calibration equipment for torsion shear curemeter

In order to check the amplitude of oscillation of the device, it shall be switched on with no test piece in it. A displacement transducer shall be used to measure the amplitude and this shall be within the tolerances specified in 3.3.

For testing linear curemeters, the displacement transducer shall be coupled by contact to one of the dies or blocks directly attached to it (see figure 4). For testing torsion shear curemeters, coupling shall be made by a knife-edge bearing in contact with a rod fixed to one of the dies (see figure 5).

The force (or torque) measuring system shall be checked by loading with weights, a weight corresponding to the full scale deflection being used.

The torque of the torsion shear curemeter shall be calculated from the product of the force F and the length of the lever arm (see figure 5). The deviation at the full scale deflection shall be less than 0,5 % (see 3.4.2).

3.6 Heating and temperature control

The method of temperature control shall guarantee the following process parameters: heating up time, curing temperature, temperature distribution and reference temperature, which are necessary for reproducible measurement of the vulcanization curve.

The instruments controlling the temperature shall permit the reference temperature (see 3.6.4) to be varied between 100 °C and 200 °C with an accuracy of $\pm 0,3$ °C.

3.6.1 Heating-up time

The apparatus shall be capable of heating the test piece to the specified curing temperature within 1,5 min of closing the die cavity.

To obtain vulcanization characteristics comparable with those obtained with the oscillating disc curemeter described in ISO 3417, the heater of the rotorless curemeter shall be adjusted so as to heat the test piece to the specified temperature in 6 min. This has given comparable results with a number

of compounds of medium filler content of the most important rubber types.

3.6.2 Curing temperature

The curing temperature is defined as the average test piece temperature. After the heating up time, this temperature shall be kept constant with an accuracy of $\pm 0,3$ °C.

3.6.3 Temperature distribution within test piece

The temperature distribution within the test piece shall be as uniform as possible.

Within the deformation zone, a tolerance of ± 1 °C of the average test piece temperature shall not be exceeded.

3.6.4 Reference temperature

The reference temperature is determined by the temperature sensor used for control. The difference between the reference temperature and the average test piece temperature shall not be more than 2 °C.

3.6.5 Measurement of temperature

The curemeter shall have a temperature-measuring device which permits the reference temperature to be determined with an accuracy of $\pm 0,3$ °C. There shall also be a facility for inserting a temperature sensor into the test piece to check the temperature distribution.

4 Test piece

4.1 General

The test piece shall be homogeneous and, as far as possible, free from trapped air.

4.2 Volume

The volume of the test piece shall exceed the volume of the cavity by a small amount and shall be determined by preliminary tests.

The recommended volume of the die cavity is between 3 cm³ and 5 cm³. Test pieces of equal volume shall be used in order to obtain reproducible results of the parameters depending upon force or torque (F_L , F_t , F_{max}).

4.3 Preparation

The test piece shall be punched out from sheeted material by an appropriate device, which ensures the production of test pieces of constant volume.

5 Procedure

5.1 Preparation for test

Bring the temperature of both dies (see 3.1) to the reference temperature with the cavity closed. Adjust the zero of the force or torque measuring device/recorder (3.4).

5.2 Loading the curemeter

Open the dies, place the test piece in the cavity and close the dies within 5 s.

The time shall be counted from the instant that the dies are closed. Oscillation of the movable die shall be started at zero time or before.

5.3 Number of tests

Usually one vulcanization curve is recorded for each test compound.

6 Expression of results

Three types of vulcanization curve can be observed. The envelope curve can rise to a maximum value, a plateau or continue to show a steady increase in force or torque after a very long time [see figure 1a)].

6.1 Force or torque values

The following force or torque values shall be read from the envelope curve:

F_L : the minimum of the vulcanization curve;

F_t : the force or torque at a specified time t ;

F_{max} : the maximum or plateau force or torque of the vulcanization curve, or the force or torque after a specified time in the case of a steady increase.

The following equation defines the conversion variable y :

$$y = \frac{F_t - F_L}{F_{max} - F_L} \times 100$$

with $y = 100$ indicating a cure of 100 %.

6.2 Scorch time t_{sx}

The scorch time t_{sx} is the time required for the force or torque to increase by x units from F_L .

6.3 Times to different percentages of full cure

The following times $t_c(y)$ can be read from the vulcanization curve:

$t_c(10)$

$t_c(50)$

$t_c(90)$

where the conversion variable y is 10 or 50 or 90 respectively (see 6.1), and

$t_c(10)$ is a measure of the beginning of cure;

$t_c(50)$ is that vulcanization time which can be evaluated most exactly;

$t_c(90)$ is often taken as the optimum cure.

6.4 Reversion

This is a decrease in maximum value of force or torque 2 min after the maximum value is obtained.

7 Test report

The test report shall include the following information:

a) Sample details:

- 1) a full description of the sample and its origin;
- 2) compound details.

b) Test method and test details:

- 1) a reference to this International Standard;
- 2) the type of curemeter used (linear or torsion shear curemeter);

- 3) the dimensions of the die cavity;
- 4) the die distance, in millimetres, if this is not the preferred value (see 3.2);
- 5) the amplitude of oscillation, in millimetres or degrees, if this is not the preferred value (see 3.3);
- 6) the frequency of oscillation, in hertz, if this is not the preferred value (see 3.3);
- 7) the force or torque range selected, in newtons or newton metres;
- 8) the paper feed speed of the recorder, in millimetres per minute;
- 9) the heating-up time, in minutes;
- 10) the curing temperature, in degrees Celsius.

c) Test results read from the vulcanization curve:

F_L : minimum force or torque, in newtons or newton metres;

F_{max} : maximum force or torque, in newtons or newton metres (or value of plateau or value after a specified time in the case of a steady increase);

t_{sc} : scorch time, in minutes (time to an increase of x units of force or torque from F_L);

$t_c(y)$: cure time, in minutes, if the conversion variable y has reached a specified value (preferably $y = 10$ or 50 or 90).

d) The date of test.

iTeh STANDARD PREVIEW
(standards.iteh.ai)

ISO 6502:1991
<https://standards.iteh.ai/catalog/standards/sist/f1429c8-4527-4011-b708-21760c15/iso-6502-1991>