

---

# International Standard



# 6525

---

INTERNATIONAL ORGANIZATION FOR STANDARDIZATION • МЕЖДУНАРОДНАЯ ОРГАНИЗАЦИЯ ПО СТАНДАРТИЗАЦИИ • ORGANISATION INTERNATIONALE DE NORMALISATION

---

## Plain bearings — Ring type thrust washers made from strip — Dimensions and tolerances

*Paliers lisses — Rondelles de butée faites à partir de matériaux en bande — Dimensions et tolérances*

First edition — 1983-12-15

**ITeH STANDARD PREVIEW**  
**(standards.iteh.ai)**

[ISO 6525:1983](#)

<https://standards.iteh.ai/catalog/standards/sist/fc763c1c-6ac4-4093-a0b8-df43b91a384a/iso-6525-1983>

---

UDC 621.822.5

Ref. No. ISO 6525-1983 (E)

**Descriptors** : bearings, plain bearings, washers (spacers), thrust washers, dimensions, dimensional tolerances.

## Foreword

ISO (the International Organization for Standardization) is a worldwide federation of national standards bodies (ISO member bodies). The work of developing International Standards is carried out through ISO technical committees. Every member body interested in a subject for which a technical committee has been authorized has the right to be represented on that committee. International organizations, governmental and non-governmental, in liaison with ISO, also take part in the work.

Draft International Standards adopted by the technical committees are circulated to the member bodies for approval before their acceptance as International Standards by the ISO Council.

International Standard ISO 6525 was developed by Technical Committee ISO/TC 123, *Plain bearings*, and was circulated to the member bodies in March 1982.

It has been approved by the member bodies of the following countries :

Austria	India	Sweden
Brazil	Italy	United Kingdom
Czechoslovakia	Korea, Rep. of	USA
Egypt, Arab Rep. of	Netherlands	USSR
France	Poland	
Germany, F.R.	Romania	

No member body expressed disapproval of the document.

# Plain bearings — Ring type thrust washers made from strip — Dimensions and tolerances

iTeh STANDARD PREVIEW  
(standards.iteh.ai)

## 1 Scope and field of application

This International Standard specifies a range of thrust washers for general purpose use with wrapped bushes as specified in ISO 3547.

It applies to thrust washers having inside diameters from 6 to 80 mm.

NOTE — It is not expected that all the sizes listed will be available from stock but adoption of standard sizes should lead to economies in tooling costs.

## 2 Reference

ISO 3547, *Plain bearings — Wrapped bushes — Dimensions, tolerances and methods of checking.*

## 3 Definition

**ring type thrust washer:** An unsplit ring, normally fitting into a recess in the end of a housing, which is intended to accept thrust and to provide axial location for a rotating shaft (see figure 1).

The standardized thrust washers are prevented from rotating by a dowel.

NOTE — Other means of location may be provided for special purpose.

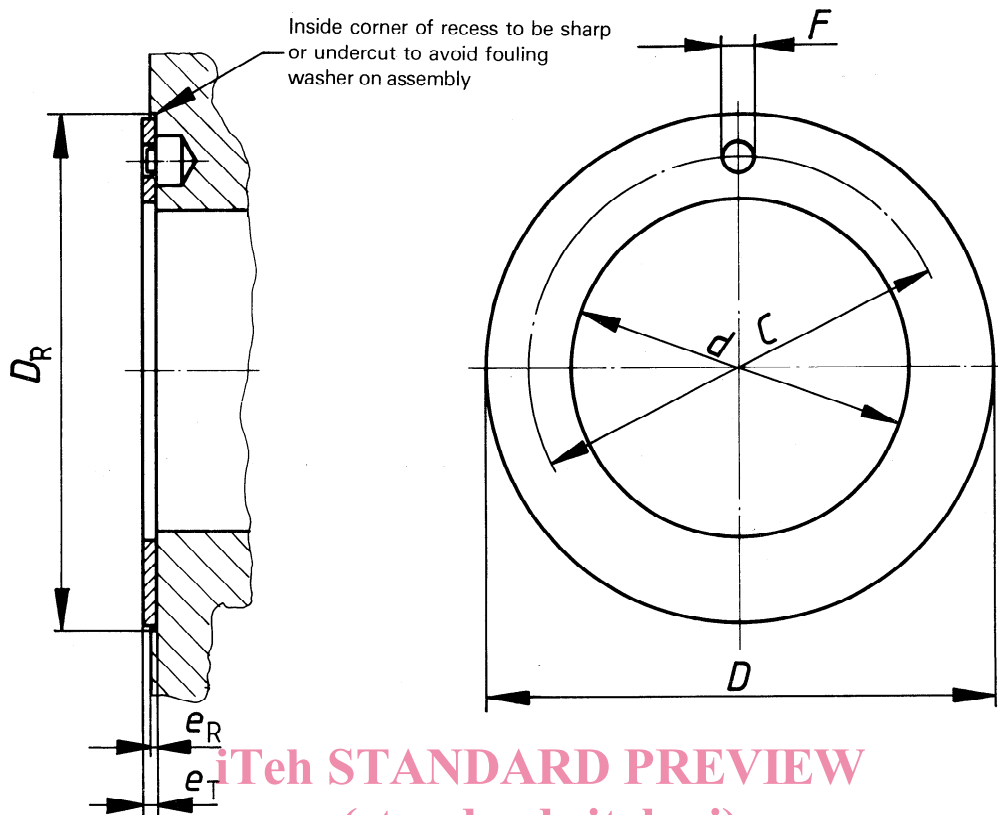

**Figure 1 – Thrust washer**

ISO 6525:1983

<https://standards.iteh.ai/catalog/standards/sist/fc763c1c-6ac4-4093-a0b8-d43b91a384a/iso-6525-1983>

**4 Symbols**

- $D$  = outside diameter of the washer
- $d$  = inside diameter of the washer
- $e_T$  = total washer thickness
- $C$  = pitch circle diameter for dowel centre
- $F$  = dowel hole diameter
- $D_R$  = diameter of recess in the housing
- $e_R$  = depth of recess in the housing
- $p$  = flatness limit

**5 Dimensions and tolerances**

The basic dimensions and tolerances for thrust washers are shown in the table.

Dimension  $D_R$  is equal to  $D$  and the tolerance for  $D_R$  is G10.

Dimension  $e_R$  is determined by the possible wear of the thrust washer and by the condition of loading in order to prevent washer escaping out of the recess if the load is reversed.

**6 Oil grooves**

By agreement between the user and the manufacturer, oil grooves may be provided.

Grooves serve the primary purpose of feeding oil over the flat areas. Sometimes, however, grooves have to be deeper than is necessary for this purpose in order to allow escape of oil from pressure-fed journal bearings. Some typical grooving arrangements are illustrated in figure 2.

**NOTES**

- 1 When grooves are embossed into bimetallic materials, the depth of groove should preferably be less than the lining thickness.
- 2 Sharp edges of grooves shall be removed.

**7 Flatness of washer**

It is not possible to specify flatness for thrust washers having oil grooving on the thrust face since the grooving operation causes distortion. In the special case of ungrooved washers, they shall slide between parallel plates set at  $e_{Tmax} + p$  where  $p = 0,10$  mm for up to 80 mm outside diameter and at  $p = 0,12$  mm above this diameter.

**8 Chamfers**

All sharp edges shall be removed.

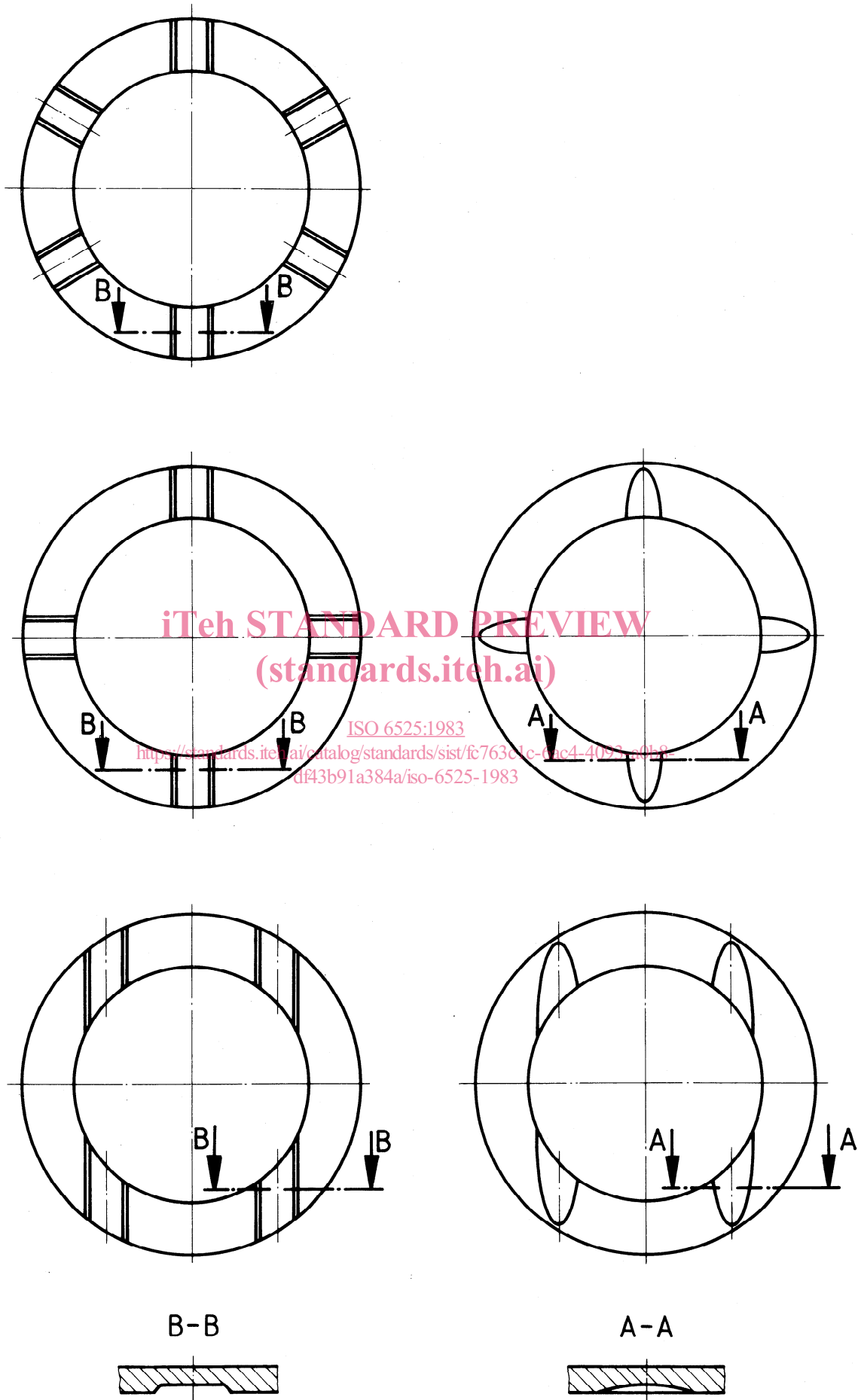

Figure 2 – Typical oil grooves

Table – Dimensions and tolerances

Dimensions in millimetres

Nominal bush housing diameter		Inside diameter, <i>d</i> + 0,25 0	Outside diameter, <i>D</i> 0 -0,25	Thickness, <i>e<sub>T</sub></i> 0 -0,05	Pitch circle diameter, <i>C</i> ± 0,15	Dowel hole diameter, <i>F</i> + 0,40 + 0,10
preferred	non-preferred					
6		6	16	1,00	11	1,5
7		7	17	1,00	12	1,5
8		8	18	1,00	13	1,5
9		9	19	1,00	14	1,5
10		10	22	1,00	16	1,5
11		12	24	1,50	18	1,5
12		12	24	1,50	18	1,5
13		14	26	1,50	20	2,0
14		14	26	1,50	20	2,0
15		16	30	1,50	23	2,0
16		16	30	1,50	23	2,0
17		18	32	1,50	25	2,0
18		18	32	1,50	25	2,0
19		20	36	1,50	28	3,0
20		20	36	1,50	28	3,0
21		22	38	1,50	30	3,0
22		22	38	1,50	30	3,0
24	23	24	42	1,50	33	3,0
24		24	42	1,50	33	3,0
25		26	44	1,50	35	3,0
26		26	44	1,50	35	3,0
28	27	28	48	1,50	39	4,0
28		28	48	1,50	39	4,0
30		32	54	1,50	43	4,0
32		32	54	1,50	43	4,0
34		36	60	1,50	48	4,0
36		36	60	1,50	48	4,0
38	39	40	64	1,50	52	4,0
40		40	64	1,50	52	4,0
40		40	64	1,50	52	4,0
42	44	45	70	1,50	57,5	4,0
45		45	70	1,50	57,5	4,0
45		45	70	1,50	57,5	4,0
48		50	76	2,00	63	4,0
50		50	76	2,00	63	4,0
53	55	55	80	2,00	67,5	5,0
53		55	80	2,00	67,5	5,0
56	57	60	90	2,00	75	5,0
56		60	90	2,00	75	5,0
60		60	90	2,00	75	5,0
63	65	65	100	2,00	83,5	5,0
63		65	100	2,00	83,5	5,0
67	70	70	105	2,00	88	5,0
67		70	105	2,00	88	5,0
71		75	110	2,00	92,5	5,0
75		75	110	2,00	92,5	5,0
80		80	120	2,00	100	5,0

**iTeh STANDARD PREVIEW**  
**(standards.iteh.ai)**

This page intentionally left blank

[ISO 6525:1983](#)

<https://standards.iteh.ai/catalog/standards/sist/fc763c1c-6ac4-4093-a0b8-df43b91a384a/iso-6525-1983>

## iTeh STANDARD PREVIEW

(This page intentionally left blank)

ISO 6525:1983

<https://standards.iteh.ai/catalog/standards/sist/fc763c1c-6ac4-4093-a0b8-df43b91a384a/iso-6525-1983>