

International Standard



6534

INTERNATIONAL ORGANIZATION FOR STANDARDIZATION • МЕЖДУНАРОДНАЯ ОРГАНИЗАЦИЯ ПО СТАНДАРТИЗАЦИИ • ORGANISATION INTERNATIONALE DE NORMALISATION

Forestry machinery — Portable chain-saws — Front hand-guard — Determination of strength

Matériel forestier — Scies à chaîne portatives — Dispositif de protection de la main tenant la poignée avant — Détermination de la solidité

First edition — 1985-09-01

ITeH STANDARD PREVIEW
(standards.iteh.ai)

ISO 6534:1985

<https://standards.iteh.ai/catalog/standards/sist/1f230459-c1cb-45b2-ac22-2228e90a7786/iso-6534-1985>

UDC 621.936.6 : 634.0.36

Ref. No. ISO 6534-1985 (E)

Descriptors : agricultural machinery, forest equipment, portable equipment, saws, screens (protectors), tests, impact tests.

Price based on 2 pages

Foreword

ISO (the International Organization for Standardization) is a worldwide federation of national standards bodies (ISO member bodies). The work of preparing International Standards is normally carried out through ISO technical committees. Each member body interested in a subject for which a technical committee has been established has the right to be represented on that committee. International organizations, governmental and non-governmental, in liaison with ISO, also take part in the work.

Draft International Standards adopted by the technical committees are circulated to the member bodies for approval before their acceptance as International Standards by the ISO Council. They are approved in accordance with ISO procedures requiring at least 75 % approval by the member bodies voting.

International Standard ISO 6534 was prepared by Technical Committee ISO/TC 23, *Tractors and machinery for agriculture and forestry*.

ITeH STANDARD PREVIEW
(standards.iteh.ai)

ISO 6534:1985

<https://standards.iteh.ai/catalog/standards/sist/1f230459-c1cb-45b2-ac22-2228e90a7786/iso-6534-1985>

Forestry machinery — Portable chain-saws — Front hand-guard — Determination of strength

1 Scope and field of application

This International Standard specifies a test method and the strength requirement for front hand-guards of portable hand-held combustion engine chain-saws for use primarily in forestry.

The hammer shall be raised to a height of 400 mm above the guard and allowed to fall so that it strikes the upper part of the guard at the centre-point of the effective guard length (the mid-point of *B* in ISO 6533) at 45° forward and downward from the guide-bar centreline. See the figure.

ISO 6534:1985

<https://standards.iteh.ai/catalog/standards/sist/1f230459-c1cb-45b2-ac22-2228e90a7786/iso-6534-1985>

2 Reference

ISO 6533, *Forestry machinery — Portable chain saws — Front hand guard — Dimensions.*

3.2 Durability test

This test shall be carried out at the standard reference temperature of $+ 20 \pm 5$ °C.

3 Test procedure

The test shall be carried out with the chain-saw rigidly held by the bar pad. If the guard also serves as the activating device for the chain-brake, it shall be in the braking position.

The hammer shall be raised to a height of 200 mm above the guard and allowed to fall so that it strikes the upper part of the guard at the centre-point of the effective guard length at 45° forward and downward from the guide-bar centreline. This test shall be repeated to a total of 25 blows.

The impact on the guard shall be generated by a blow from a steel hammer, suspended on a pendulum length of 700 mm. The hammer shall have an effective mass of 2,5 kg and be a cylinder of 85 mm diameter. The pendulum arm shall be in the same line as the cylinder axis.

3.1 Dynamic test

This test shall be carried out at temperatures of $+ 40 \pm 2$ °C and -25 ± 3 °C, measured at the front hand-guard and its mounting.

4 Test requirements

The front hand-guard shall not break or crack when tested in accordance with clause 3. The guard shall not deflect as far as to allow the pendulum to swing past. Before and after the test, the dimensions of the guard shall comply with the specifications of ISO 6533.

Dimensions in millimetres

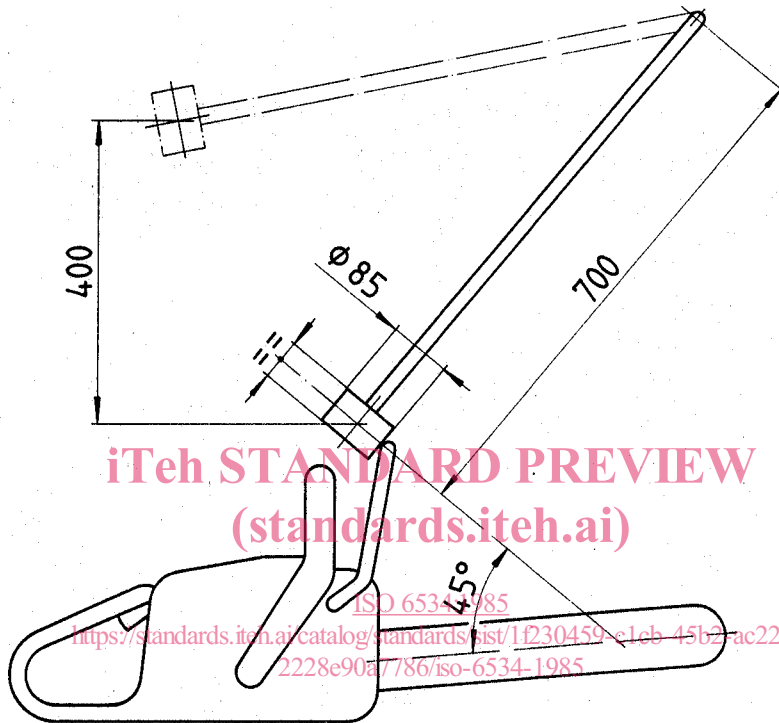

Figure — Dynamic test