International Standard



6602

INTERNATIONAL ORGANIZATION FOR STANDARDIZATION • МЕЖДУНАРОДНАЯ ОРГАНИЗАЦИЯ ПО СТАНДАРТИЗАЦИИ • ORGANISATION INTERNATIONALE DE NORMALISATION

Plastics — Determination of flexural creep by three-point loading

Plastiques — Détermination du fluage en flexion par sollicitation en trois points

First edition — 1985-07-15

ITeH STANDARD PREVIEW
(standards.iteh.ai)

[ISO 6602:1985](https://standards.iteh.ai/catalog/standards/sist/ea2e85ec-6688-4373-a358-ab2a2ed26ed7/iso-6602-1985)

<https://standards.iteh.ai/catalog/standards/sist/ea2e85ec-6688-4373-a358-ab2a2ed26ed7/iso-6602-1985>

UDC 678.5/.8 : 620.174

Ref. No. ISO 6602-1985 (E)

Descriptors : plastics, tests, creep tests, test equipment.

Price based on 6 pages

Foreword

ISO (the International Organization for Standardization) is a worldwide federation of national standards bodies (ISO member bodies). The work of preparing International Standards is normally carried out through ISO technical committees. Each member body interested in a subject for which a technical committee has been established has the right to be represented on that committee. International organizations, governmental and non-governmental, in liaison with ISO, also take part in the work.

Draft International Standards adopted by the technical committees are circulated to the member bodies for approval before their acceptance as International Standards by the ISO Council. They are approved in accordance with ISO procedures requiring at least 75 % approval by the member bodies voting.

International Standard ISO 6602 was prepared by Technical Committee ISO/TC 61, *Plastics*.

iTeh STANDARD PREVIEW
(standards.itih.ai)

[ISO 6602:1985](https://standards.itih.ai/catalog/standards/sist/ea2e85ec-6688-4373-a358-ab2a2ed26ed7/iso-6602-1985)

<https://standards.itih.ai/catalog/standards/sist/ea2e85ec-6688-4373-a358-ab2a2ed26ed7/iso-6602-1985>

Plastics — Determination of flexural creep by three-point loading

1 Scope and field of application

1.1 This International Standard describes a method for determining the flexural creep of plastics in the form of standard test specimens under defined conditions such as pre-treatment, temperature and humidity. It applies only to a simple freely supported beam, loaded at mid-span (three-point loading test).

1.2 The method is suitable for use with rigid and semi-rigid (see ISO 472 for definitions) non-reinforced, filled and fibre-reinforced plastic materials in the form of rectangular bars moulded directly, or cut from sheets or moulded shapes.

NOTE — The method may be unsuitable for certain fibre-reinforced materials whose fibre orientation is not symmetrical with the loading direction.

1.3 The method may not be suitable for determining the flexural creep of rigid cellular plastics and attention is drawn to ISO 1209.

1.4 The method may provide data for quality control, quality assurance and for research and development.

1.5 Flexural creep may vary significantly with differences in specimen preparation and dimensions and the testing environment. Consequently, where precise comparative results are required, these factors must be carefully controlled.

1.6 If flexural properties are to be used for engineering design purposes, the sensitivity of plastic materials necessitates testing over a broad range of stress, time and environment.

2 References

ISO 178, *Plastics — Determination of flexural properties of rigid plastics.*

ISO 291, *Plastics — Standard atmospheres for conditioning and testing.*

ISO 472, *Plastics — Vocabulary.*

ISO 899, *Plastics — Determination of tensile creep.*

ISO 1209, *Rigid cellular plastics — Rigid bending test.*

3 Definitions

For the purpose of this International Standard, the following definitions apply:

3.1 creep: The increase of strain with time, when a constant stress is applied. It is expressed by the time-dependent strain resulting from a constant stress.

3.2 flexural stress, σ : The maximum nominal surface stress in the section of the test specimen at mid-span. It is calculated according to the relationship given in 7.1.2.

3.3 deflection, $d(t)$: The distance over which the top or bottom surface of the test specimen at mid-span has deviated during flexure from its position before application of the test load.

3.4 flexural creep strain, $\varepsilon(t)$: The maximum nominal strain in the surface of the test specimen produced by the applied stress at any given time during a creep test, calculated as in 7.1.3.

3.5 flexural creep modulus, $E(t)$: The ratio of applied flexural stress to flexural creep strain, calculated as in 7.1.1.

4 Apparatus

The testing apparatus shall consist of the following components (see figure 1):

4.1 Test rack

A suitable rigid rack shall be used which provides free support of specimens at both ends on a span equal to (16 ± 1) times the thickness (height) of the specimen. Sufficient space must be allowed below the specimens for dead-weight loading at mid-span. The test rack shall be level.

NOTE — In some cases it may be necessary to use a test rack with a span greater than 17 times the thickness (height) of the test specimen (see the note in 6.2).

4.1.1 The radius r_1 of the loading nose and the radius r_2 of the supports shall be as given in table 1.

Table 1

Values in millimetres

Thickness of test specimen	r_1	r_2
< 3	$5 \pm 0,1$	$2 \pm 0,2$
> 3	$5 \pm 0,1$	$5 \pm 0,2$

4.1.2 The span L shall be adjustable.

4.2 Loading system

So designed that the load applied and maintained on the test specimen at mid-span is within $\pm 1\%$ of the desired load. The loading mechanism shall allow rapid, smooth and reproducible loading (see 6.4.2).

4.3 Deflection-measuring device for measuring the deflection of the test specimen under load

Any device that will not influence the test specimen behaviour by mechanical effects (undesirable deformations, notches, etc.), other physical effects (heating of test specimen, etc.) or chemical effects is suitable. The accuracy of the deflection measuring device shall be $\pm 1\%$ of the final deflection to be measured.

4.4 Time-measurement device

Any modern stop-watch or similar device is suitable.

4.5 Micrometers

4.5.1 **Micrometer**, reading to 0,01 mm or better, for measuring the thickness and width of the test specimen.

4.5.2 **Vernier caliper**, accurate to 0,1 % of the span or better, for determining the span.

5 Test specimens

5.1 General

The test specimen shall have constant rectangular cross-sections (without rounded edges). The variation in width and thickness along a test specimen shall not exceed 2 %.

The test specimen shall be free from twist and substantially flat.

5.2 Standard test specimens

The standard dimensions in millimetres shall be

length	$l = 80 \pm 5$
width	$b = 10 \pm 0,5$
thickness	$h = 4 \pm 0,2$

5.3 Other test specimens

When it is not possible to use the standard test specimen, the following rules shall be observed (but see notes 1 and 2):

a) the length and thickness of the test specimen shall be in the same ratio as in the standard test specimen, that is :

$$l = (20 \pm 1,3)h$$

b) the width of the test specimen shall be as given in table 2.

Table 2

Values in millimetres

Nominal thickness	Width
h	b
$1 < h < 3$	25
$3 < h < 5$	10
$5 < h < 10$	15
$10 < h < 20$	20
$20 < h < 35$	35
$35 < h < 50$	50

$\pm 0,5$

NOTES

1 The preparation and dimensions of the test specimen may be defined by the standard for the material.

2 When very coarse textile glass fibre roving or other very coarse fillers are used, it may be necessary to increase the width of the test specimen.

ISO 6602:1985

<https://standards.iteh.ai/catalog/standards/sist/ea2e85ec-6688-4373-a358-ab2a2ed26ed7/iso-6602-1985>

5.4 Anisotropic materials

In the case of anisotropic materials, the test specimens shall be chosen so that the flexural stress in the test procedure will be applied in the same direction as that to which products (moulded articles, sheets, tubes, etc.) similar to those from which the test specimen are taken, will be subjected in service, where this is known.

The relationship of the test specimens chosen to the application will determine the possibility or impossibility of using standard test specimens and, in the latter case, will govern the choice of the dimensions of the test specimens in accordance with 5.3.

It should be noted that the position or orientation and the dimensions of the test specimens sometimes have a very significant influence on the test results. This is particularly true of laminates.

NOTE — When the material shows a significant difference in flexural properties in two principal directions, it should be tested in these two directions. If, because of the application, such a material is subjected to stress at some specific orientation to the principal direction, it is desirable to test the material in that orientation.

5.5 Number of test specimens

The minimum number of test specimens at each stress level shall normally be two.

5.6 Conditioning of test specimens

The test specimens shall be conditioned in accordance with the requirements of the International Standard for the material. In the absence of this information, use shall be made of the normal tolerance conditions given in ISO 291, unless otherwise agreed by the interested parties.

The preferred condition is atmosphere 23/50, except where the flexural creep properties of the material are known to be insensitive to moisture, in which case humidity control is unnecessary.

6 Procedure

6.1 Test atmosphere

Carry out the test in one of the standard atmospheres specified in ISO 291, preferably the same atmosphere as used for conditioning.

6.2 General directions

Measure the width b of the test specimen to the nearest 0,1 mm and the thickness h to the nearest 0,02 mm in three positions within the central third of the test specimen and equidistant from the ends. Calculate the mean width and thickness.

Adjust the length of the span L , to

$$L = (16 \pm 1)h.$$

Measure the length of the span to within 0,5 %.

NOTE — For very thick and unidirectional fibre-reinforced test specimens, it may be necessary to use a distance between supports calculated on a higher ratio of L/h to avoid delamination in shear.

6.3 Mounting of the test specimens

The test specimen shall be mounted symmetrically with its long axis at right angles to the supports.

6.4 Loading procedure

6.4.1 Preloading

Where it is necessary to preload the test specimen, care shall be taken to ensure that the preloading will not cause a measurable effect. The preloading shall not be applied before the temperature and humidity of the test specimen (finally positioned in the testing apparatus) correspond to the test conditions.

The deflection-measuring device (4.3) shall be set to zero after the application of preloading; the preload shall act during the whole time of the test. The additional load after preloading shall be taken as the test load.

6.4.2 Loading of the test specimen

Set the deflection-measuring device to zero before applying the test load (see 4.2).

The loading of the test specimen (the temperature and humidity of which correspond to the test conditions) shall be done continuously. The rate of loading in a series of tests of one material shall be the same for each test and shall be recorded. The moment of full loading of the test specimen shall be precisely determined; it shall preferably be within 1 to 5 s and, in any case, no more than 10 s after the beginning of the application of the load.

6.4.3 Stress levels

A minimum of three stress levels shall be selected preferably from the following list of flexural stresses σ :

$$\sigma: 0,5; 1; 2; 5; 10; 20; 50; \dots \text{ MPa.}$$

NOTE — The stress should be chosen such that the deflection is never greater than 0,1 times the span.

6.5 Programme of deflection measurements

The moment of full loading of the specimen shall be denoted as the time $t = 0$. Unless the deflection is automatically and/or continuously recorded, the times for measuring shall be chosen individually with respect to the course of the curve. Preferably the following time schedule should be used:

$$1, 3, 6, 12 \text{ and } 30 \text{ min; } 1, 2, 5, 10, 20, 50, 100, 200, 500, 1000 \text{ h...}$$

6.6 Time measurement

The accuracy of the time measurement shall be ± 1 % of the elapsed time at each creep measurement.

6.7 Temperature and humidity control

Unless temperature and relative humidity are automatically recorded, readings of the respective measuring instruments shall be made at the beginning of the test and shall subsequently be checked at least three times a day or until an assurance has been obtained that the conditions are holding within the limits with less frequent checking.

7 Expressions of results

7.1 Calculations

7.1.1 The flexural creep modulus $E(t)$ is given, in megapascals, by the equation

$$E(t) = \frac{L^3}{4bh^3} \times \frac{F}{d(t)}$$

where

L is the span, in millimetres;

b is the width of the test specimen, in millimetres;

h is the thickness (height) of the test specimen, in millimetres;

F is the load, in newtons;

$d(t)$ is the time-dependent deflection at mid-span corresponding to the load F , in millimetres.

7.1.2 the flexural stress σ is given, in megapascals, by the equation

$$\sigma = \frac{3FL}{2bh^2}$$

where

F is the load, in newtons;

L is the span, in millimetres;

b is the width of the test specimen, in millimetres;

h is the thickness (height) of the test specimen, in millimetres.

7.1.3 The flexural creep strain $\varepsilon(t)$, expressed as a percentage, is given by the equation:

$$\varepsilon(t) = \frac{600 d(t) h}{L^2}$$

where

$d(t)$ is the time-dependent deflection at mid-span corresponding to load F , in millimetres;

h is the thickness (height) of the test specimen, in millimetres;

L is the span, in millimetres.

7.1.4 Isochronous stress-strain curves

Isochronous stress-strain curves are cartesian plots of the applied flexural stress used in the flexural creep test versus the flexural creep strain at a specific time, normally 1 000 h. Since only one point of an isochronous plot is obtained from each creep test, it is usually necessary to use at least three stress levels, and preferably more to obtain an isochronous plot (see figure 2).

7.2 Presentation of data

7.2.1 The primary data (see figure 2) shall normally be presented as creep curves showing the average of the two individual flexural strains against logarithmic time at different stress levels which can be selected from the values given in 6.4.3. These data may be presented in other ways, as described, for example, in 7.2.2 and 7.2.3 to provide information for particular requirements.

7.2.2 Isochronous stress-strain curves are obtained either by sections of constant time on the creep curves or by calculating corresponding stress and strain values according to 7.1.2 and 7.1.3. Times should be chosen from the values given in 6.5.

7.2.3 Isometric stress-time curves are obtained by constructing sections of constant strain on the creep curves. Strains should be selected from the following values:

0,1 %, 0,15 %, 0,2 %, 0,3 %, 0,5 %, 1 %, 1,5 %, 2 % and 3 %.

8 Test report

The test report shall include the following information:

- a) reference to this International Standard;
- b) description of the material tested, including all pertinent information on composition, manufacturer, trade name, code number, date of manufacture, type of moulding, annealing, etc., where these are known;
- c) dimensions of test specimens;
- d) method of preparation, including subsequent thermal treatment or conditioning;
- e) temperature and humidity of test (where relevant);
- f) the ratio of span to thickness (height), if other than 16 (see the note in 6.2);
- g) creep test data, presented in one or more of the graphical forms according to 7.2, or in tabular form;
- h) the directions of the principal axes of the test specimens with respect to the dimensions of the product or some known or inferred orientation in the material;
- j) surface of force application.

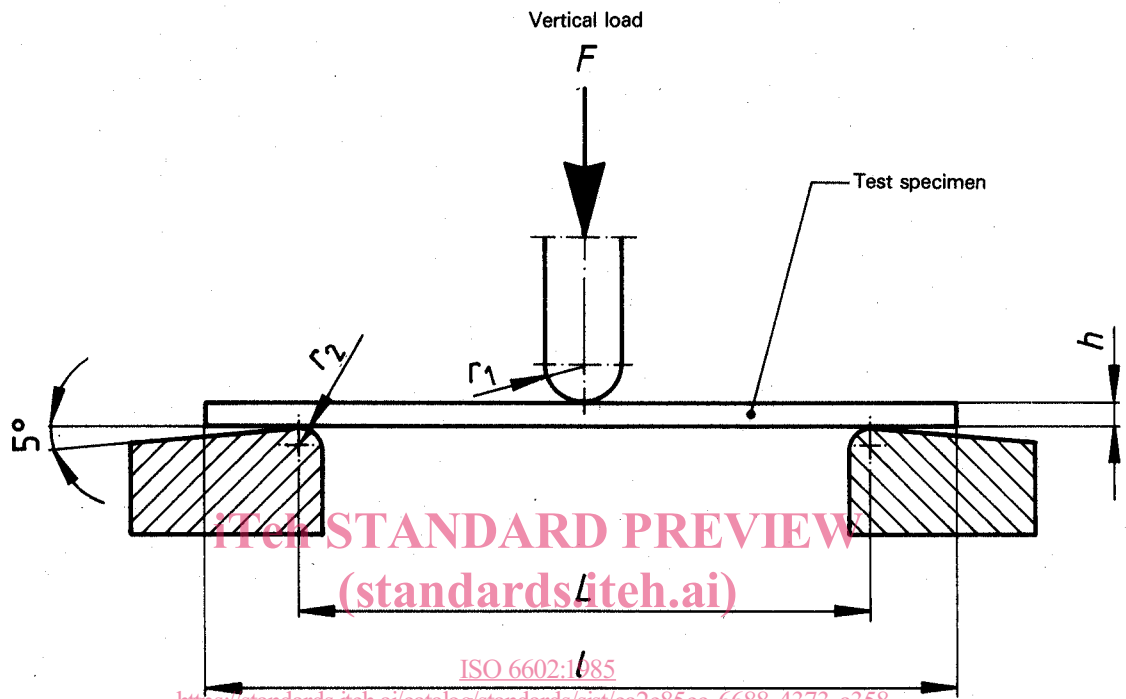

STANDARD PREVIEW
 (standards.iteh.ai)
 ISO 6602:1985
<https://standards.iteh.ai/catalog/standards/sist/ea2e85ec-6688-4373-a358-ab2a2ed26ed7/iso-6602-1985>

Figure 1 – Characteristics of the apparatus

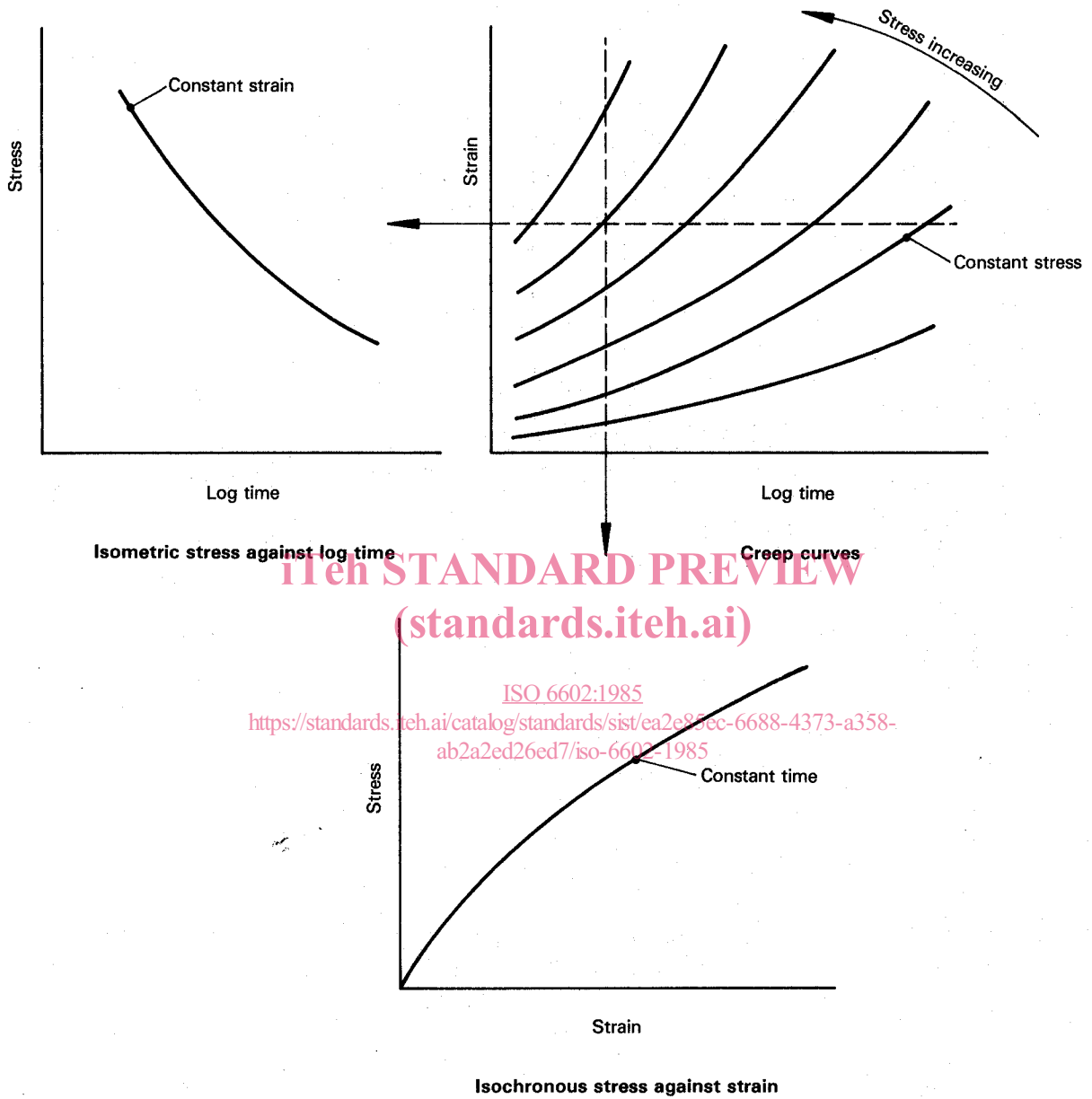

Figure 2 — Creep data — Three methods of presentation