International Standard



6638/1

INTERNATIONAL ORGANIZATION FOR STANDARDIZATION • МЕЖДУНАРОДНАЯ ОРГАНИЗАЦИЯ ПО СТАНДАРТИЗАЦИИ • ORGANISATION INTERNATIONALE DE NORMALISATION

**Fruit and vegetable products — Determination
of formic acid content —
Part 1 : Gravimetric method**

Produits dérivés des fruits et légumes — Détermination de la teneur en acide formique — Partie 1: Méthode gravimétrique

First edition — 1985-12-01

ITeH STANDARD PREVIEW
(standards.iteh.ai)

[ISO 6638-1:1985](https://standards.iteh.ai/catalog/standards/sist/717ceb93-13cc-4654-95d9-6ad379fcd8dc/iso-6638-1-1985)

<https://standards.iteh.ai/catalog/standards/sist/717ceb93-13cc-4654-95d9-6ad379fcd8dc/iso-6638-1-1985>

UDC 634.1/635.6 : 543.8 : 547.291

Ref. No. ISO 6638/1-1985 (E)

Descriptors : agricultural products, fruits, vegetables, fruit and vegetable products, chemical analysis, determination of content, formic acid, gravimetric analysis.

Price based on 3 pages

Foreword

ISO (the International Organization for Standardization) is a worldwide federation of national standards bodies (ISO member bodies). The work of preparing International Standards is normally carried out through ISO technical committees. Each member body interested in a subject for which a technical committee has been established has the right to be represented on that committee. International organizations, governmental and non-governmental, in liaison with ISO, also take part in the work.

Draft International Standards adopted by the technical committees are circulated to the member bodies for approval before their acceptance as International Standards by the ISO Council. They are approved in accordance with ISO procedures requiring at least 75 % approval by the member bodies voting.

International Standard ISO 6638/1 was prepared by Technical Committee ISO/TC 34, *Agricultural food products*.

Users should note that all International Standards undergo revision from time to time and that any reference made herein to any other International Standard implies its latest edition, unless otherwise stated.

Fruit and vegetable products — Determination of formic acid content — Part 1 : Gravimetric method

1 Scope and field application

This part of ISO 6638 specifies a gravimetric method for the determination of the formic acid content of fruit and vegetable products.

A titrimetric method is specified in ISO 6638/2.

2 Principle

Quantitative entrainment by steam of the formic acid present in a test portion and reduction of mercury(II) chloride by the formic acid to mercury(I) chloride. Determination of the formic acid content from the yield of mercury(I) chloride.

3 Reagents

All reagents shall be of recognized analytical quality and the water used shall be distilled water or water of at least equivalent purity.

3.1 Barium carbonate or calcium carbonate.

3.2 Mercury(II) chloride and sodium chloride solution.

Dissolve 100 g of mercury(II) chloride and 30 g of sodium chloride in water and dilute to 1 000 ml.

3.3 Sodium acetate, 500 g/l solution.

3.4 Hydrochloric acid, 10 % (V/V) solution.

3.5 Tartaric acid.

3.6 Ethanol.

3.7 Diethyl ether.

4 Apparatus

Usual laboratory equipment, and in particular :

4.1 Analytical balance.

4.2 Distillation apparatus as shown in the figure, or equivalent apparatus, comprising:

4.2.1 Steam generator, made of metal or glass, of capacity 5 litres.

4.2.2 Flasks A and B, each of capacity 500 ml.

4.2.3 Condenser, of length 50 cm.

4.2.4 Conical flask, of capacity 2 litres.

4.3 Schott filter G4 or sintered glass filter of pore size 10 to 20 μm .

4.4 Desiccator, containing an efficient desiccant.

4.5 Oven, well ventilated, thermostatically controlled at 100 ± 2 °C.

4.6 Mixer and/or mechanical grinder.

4.7 Conical flask, of capacity 500 ml.

4.8 Filter paper, Whatman No. 1 or equivalent.

4.9 Hotplate.

4.10 Evaporating dish, of capacity at least 300 ml.

4.11 Reflux condenser.

4.12 Boiling water bath.

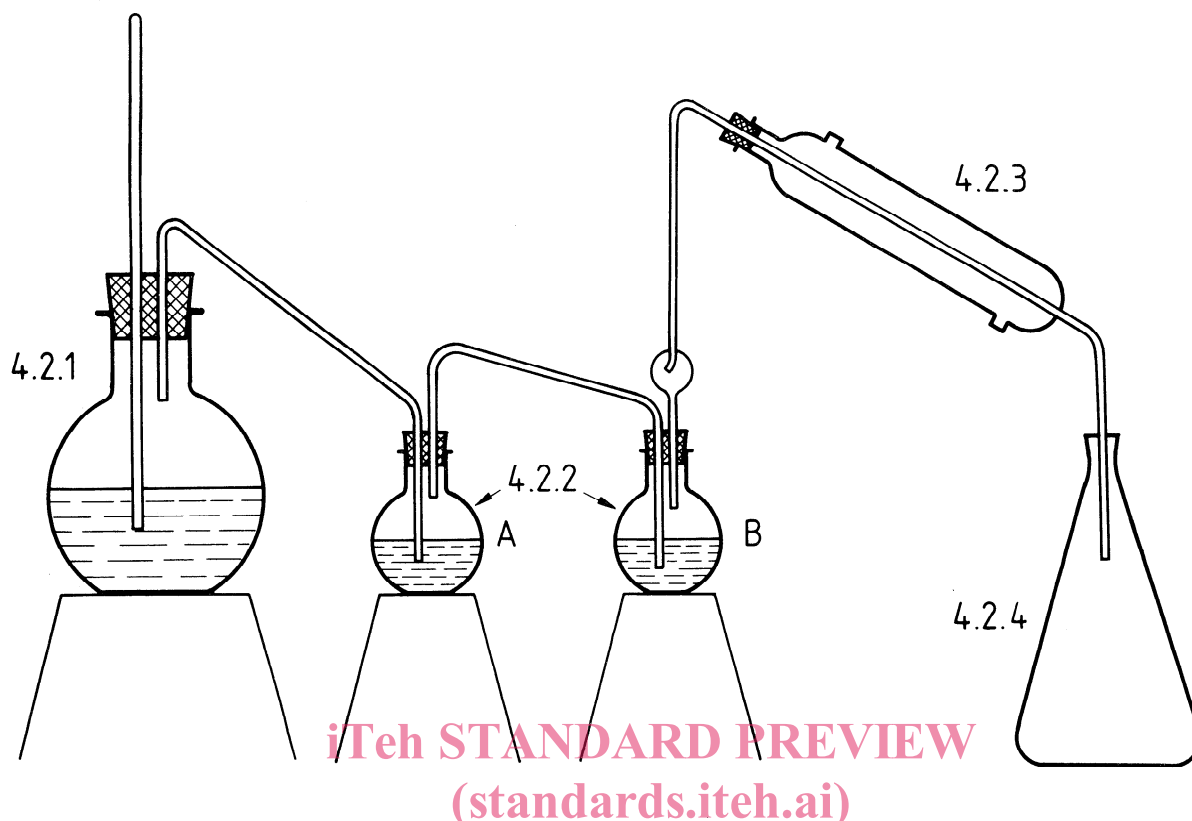

Figure — Distillation apparatus (4.2)
<https://standards.iteh.ai/catalog/standards/sist/717ceb93-13cc-4654-95d9-6ad379fcd8dc/iso-6638-1-1985>

5 Procedure

5.1 Preparation of the test sample

Thoroughly mix the laboratory sample. If necessary, first remove stones and hard seed-cavity walls and pass through a mechanical grinder.

Allow frozen or deep-frozen products to thaw in a closed vessel and add the liquid formed during this process to the product before mixing.

5.2 Test portion

5.2.1 Liquid products

Take, by means of a pipette, 25 to 50 ml of the test sample (5.1) containing not more than 0,15 g of formic acid, transfer to flask A (4.2.2) and add water to bring the total volume to 100 ml.

NOTE — The test portion may also be taken by mass, by weighing, to the nearest 0,01 g, 25 to 50 g of the test sample.

5.2.2 Pasty or solid products

Weigh, to the nearest 0,01 g, 25 to 50 g of the test sample (5.1), transfer to flask A (4.2.2) and add water to bring the total volume to 100 ml.

NOTE — In certain cases, it is necessary to leave the test portion to soak in the water for 1 to 2 h.

5.3 Distillation

5.3.1 Add 0,5 to 1,0 g of the tartaric acid (3.5) to the contents of flask A.

Transfer 2 g of the barium carbonate or calcium carbonate (3.1) to flask B and add water to bring the total volume to 100 ml.

5.3.2 Connect the flasks A and B to the steam generator (4.2.1) and condenser (4.2.3), as shown in the figure, and heat the flasks and the steam generator simultaneously.

Carry out the distillation ensuring that the volumes of the contents of flasks A and B remain constant to within 5 ml. Collect 1 000 to 1 500 ml of distillate in the conical flask (4.2.4). Discard the distillate.

5.3.3 After distillation, filter the hot contents of flask B through the filter paper (4.8) into a 500 ml conical flask (4.7) and rinse the precipitate with hot water, collecting the rinsings until the total volume of filtrate is 250 ml. Transfer the filtrate to an evaporating dish (4.10). Evaporate the filtrate on the hotplate (4.9) to reduce the volume to about 100 ml.

5.3.4 Add to the remaining filtrate:

- 10 ml of the sodium acetate solution (3.3);
- 2 ml of the hydrochloric acid solution (3.4);
- 25 ml of the mercury(II) chloride and sodium chloride solution (3.2).

Mix well and boil this solution under reflux on a boiling water bath for 2 h. [The calcium or barium formate reduces mercury(II) chloride to mercury(I) chloride.]

5.3.5 Filter the precipitate of mercury(I) chloride under suction through the Schott filter (4.3) previously dried at 100 °C in the oven (4.5), cooled in the desiccator (4.4) and weighed to the nearest 0,000 2 g.

Wash the mercury(I) chloride with cold water, ethanol (3.6) and diethyl ether (3.7) and dry in the oven (4.5), controlled at 100 ± 2 °C, for 1 h.

5.3.6 Allow the Schott filter and mercury(I) chloride to cool in the desiccator (4.4) to ambient temperature and weigh to the nearest 0,000 2 g.

5.4 Number of determinations

Carry out two determinations on the same test sample (5.1).

6 Expression of results

6.1 Method of calculation and formulae

The formic acid content, expressed in grams per 100 ml or per 100 g of sample, is equal to

a) in the case of test portions taken by volume

$$\frac{(m_2 - m_1) \times 0,097\ 5 \times 100}{V}$$

b) in the case of test portions taken by mass

$$\frac{(m_2 - m_1) \times 0,097\ 5 \times 100}{m_0}$$

where

m_0 is the mass, in grams, of the test portion;

m_1 is the mass, in grams, of the Schott filter;

m_2 is the mass, in grams, of the Schott filter and mercury(I) chloride;

V is the volume, in millilitres, of the test portion;

0,097 5 is the mass, in grams, of formic acid equivalent to 1 g of mercury(I) chloride.

Take as the result the arithmetic mean of the values obtained in the two determinations (5.4) provided that the requirement for repeatability (see 6.2) is satisfied.

Report the result to three decimal places.

6.2 Repeatability

The difference between the values obtained in the two determinations (5.4), carried out simultaneously or in rapid succession by the same analyst, shall not exceed 2 % of the mean.

7 Test report

The test report shall show the method used and the result obtained. It shall also mention any operating conditions not specified in this part of ISO 6638, or regarded as optional, as well as any circumstances that may have influenced the results.

The test report shall include all the details required for the complete identification of the sample.

iTeh STANDARD PREVIEW
(standards.iteh.ai)

This page intentionally left blank

ISO 6638-1:1985

<https://standards.iteh.ai/catalog/standards/sist/717ceb93-13cc-4654-95d9-6ad379fcd8dc/iso-6638-1-1985>

iTeh STANDARD PREVIEW
(standards.iteh.ai)

This page intentionally left blank

ISO 6638-1:1985

<https://standards.iteh.ai/catalog/standards/sist/717ceb93-13cc-4654-95d9-6ad379fcd8dc/iso-6638-1-1985>

iTeh STANDARD PREVIEW
(standards.iteh.ai)

This page intentionally left blank

ISO 6638-1:1985

<https://standards.iteh.ai/catalog/standards/sist/717ceb93-13cc-4654-95d9-6ad379fcd8dc/iso-6638-1-1985>