



SLOVENSKI STANDARD

SIST EN 28768:1998

01-oktober-1998

**Embalaža - Celovita, napolnjena transportna embalaža - Preskus s prevračanjem
(ISO 8768:1986)**

Packaging - Complete, filled transport packages - Toppling test (ISO 8768:1986)

Verpackung - Versandfertige Packstücke - Umsturzprüfung (ISO 8768:1986)

Emballages - Emballages d'expédition complets et pleins - Essai de basculement (ISO 8768:1986)

STANDARD PREVIEW
(standards.iteh.ai)

Ta slovenski standard je istoveten z: **EN 28768:1992**

SIST EN 28768:1998
<https://standards.iteh.ai/catalog/standards/sist/109c1516-8c60-4767-99b4-c902343154fb/sist-en-28768-1998>

ICS:

55.180.40	Celovita, napolnjena transportna embalaža	Complete, filled transport packages
-----------	---	-------------------------------------

SIST EN 28768:1998

en

iTeh STANDARD PREVIEW
(standards.iteh.ai)

SIST EN 28768:1998

<https://standards.iteh.ai/catalog/standards/sist/109cf31b-8e60-4767-99b4-c902343154fb/sist-en-28768-1998>

EUROPEAN STANDARD

EN 28768:1992

NORME EUROPÉENNE

EUROPÄISCHE NORM

November 1992

UDC 621.798.1:620.165.72

Descriptors: Packing, transport packing, complete- and filled packages, drop tests

English version

**Packaging - Complete, filled transport packages -
Toppling test (ISO 8768:1986)**

Emballages - Emballages d'expédition complets et pleins - Essai de basculement (ISO 8768:1986) -
Verpackung - Versandfertige Packstücke - Umsturzprüfung (ISO 8768:1986)

STANDARD PREVIEW
(standards.iteh.ai)

SIST EN 28768:1998

<https://standards.iteh.ai/catalog/standards/sist/109c31b-8e60-4767-99b4-c902343154fb/sist-en-28768-1998>

This European Standard was approved by CEN on 1992-10-30. CEN members are bound to comply with the CEN/CENELEC Internal Regulations which stipulate the conditions for giving this European Standard the status of a national standard without any alteration.

Up-to-date lists and bibliographical references concerning such national standards may be obtained on application to the Central Secretariat or to any CEN member.

The European Standards exist in three official versions (English, French, German). A version in any other language made by translation under the responsibility of a CEN member into its own language and notified to the Central Secretariat has the same status as the official versions.

CEN members are the national standards bodies of Austria, Belgium, Denmark, Finland, France, Germany, Greece, Iceland, Ireland, Italy, Luxembourg, Netherlands, Norway, Portugal, Spain, Sweden, Switzerland and United Kingdom.

CEN

European Committee for Standardization
Comité Européen de Normalisation
Europäisches Komitee für Normung

Central Secretariat: rue de Stassart, 36 B-1050 Brussels

Foreword

In 1991, ISO 8768:1986 "Packaging - Complete, filled transport packages - Toppling test" was submitted to the CEN Primary Questionnaire procedure.

Following the positive result of the CEN/CS Proposal ISO 8768:1986 was submitted to the Formal Vote.

The result of the Formal Vote was positive.

This European Standard shall be given the status of a national standard, either by publication of an identical text or by endorsement, at the latest by May 1993, and conflicting national standards shall be withdrawn at the latest by May 1993.

According to the CEN/CENELEC Internal Regulations, the following countries are bound to implement this European Standard: Austria, Belgium, Denmark, Finland, France, Germany, Greece, Iceland, Ireland, Italy, Luxembourg, Netherlands, Norway, Portugal, Spain, Sweden, Switzerland, United Kingdom.

(standards.iteh.ai)

SIST EN 28768:1998

[https://standards.iteh.ai/catalog/standards/sist/109c31b-8e60-4767-99b4-](https://standards.iteh.ai/catalog/standards/sist/109c31b-8e60-4767-99b4-c90234515416/sist-en-28768-1998)

Endorsement notice

[c90234515416/sist-en-28768-1998](https://standards.iteh.ai/catalog/standards/sist/109c31b-8e60-4767-99b4-c90234515416/sist-en-28768-1998)

The text of the International Standard ISO 8768:1986 was approved by CEN as a European Standard without any modification.

International Standard



8768

INTERNATIONAL ORGANIZATION FOR STANDARDIZATION • МЕЖДУНАРОДНАЯ ОРГАНИЗАЦИЯ ПО СТАНДАРТИЗАЦИИ • ORGANISATION INTERNATIONALE DE NORMALISATION

Packaging — Complete, filled transport packages — Toppling test

Emballages — Emballages d'expédition complets et pleins — Essai de basculement

First edition — 1986-12-15

iTeh STANDARD PREVIEW
(standards.iteh.ai)

[SIST EN 28768:1998](#)

<https://standards.iteh.ai/catalog/standards/sist/109cf31b-8e60-4767-99b4-c902343154fb/sist-en-28768-1998>

UDC 621.798.1 : 620.165.7

Ref. No. ISO 8768-1987 (E)

Descriptors : packing, transport packing, complete-and filled packages, tests, drop tests.

Foreword

ISO (the International Organization for Standardization) is a worldwide federation of national standards bodies (ISO member bodies). The work of preparing International Standards is normally carried out through ISO technical committees. Each member body interested in a subject for which a technical committee has been established has the right to be represented on that committee. International organizations, governmental and non-governmental, in liaison with ISO, also take part in the work.

Draft International Standards adopted by the technical committees are circulated to the member bodies for approval before their acceptance as International Standards by the ISO Council. They are approved in accordance with ISO procedures requiring at least 75 % approval by the member bodies voting.

International Standard ISO 8768 was prepared by Technical Committee ISO/TC 122, *Packaging*.

Users should note that all International Standards undergo revision from time to time and that any reference made herein to any other International Standard implies its latest edition, unless otherwise stated.

iTeh STANDARD PREVIEW
(standards.iteh.ai)

<https://standards.iteh.ai/catalog/standards/sist/109cf31b-8e60-4767-99b4-c902343154fb/sist-en-28768-1998>

Packaging — Complete, filled transport packages — Toppling test

1 Scope and field of application

This International Standard specifies a method for carrying out a toppling test on a complete, filled transport package which may be exposed to the danger of toppling during storage, transport and handling. The test may be used to assess the performance of a package in terms of its strength or the protection that it offers to its contents when it is subject to toppling. It may be performed either as a single test to investigate the effects of toppling or as part of a sequence of tests designed to measure the ability of the package to withstand a distribution system that includes a toppling hazard.

The test, which is complementary to the tests described in ISO 2244, ISO 2248 and ISO 2876, may be used to investigate the performance of packages which are tall in relation to their base dimensions. It is also applicable to packages the height of which is small by comparison with base dimensions but which may be stored or transported resting on a side face in order to conserve storage/transport space (see figures 1 and 2). The test is recommended for packages where the ratio of the longest to the shortest sides is of the order of 3 : 1 or greater.

2 References

ISO 2206, *Packaging — Complete, filled transport packages — Identification of parts when testing.*

ISO 2233, *Packaging — Complete, filled transport packages — Conditioning for testing.*

ISO 2244, *Packaging — Complete, filled transport packages — Horizontal impact tests (horizontal or inclined plane test; pendulum test).*

ISO 2248, *Packaging — Complete, filled transport packages — Vertical impact test by dropping.*

ISO 2876, *Packaging — Complete, filled transport packages — Rolling test.*

3 Principle

In simple testing, placing of the test package on a flat, horizontal surface and subjection of the package to an increasing

horizontal force applied at a position above its centre of gravity until it topples freely about a lower edge. The atmospheric conditions and package attitude are predetermined.

4 Apparatus

4.1 Impact surface, horizontal and flat, massive enough to be immovable and rigid enough to be non-deformable under test conditions.

In normal circumstances, the impact surface provided shall be

— flat, so that no two points on its surface differ in level by more than 2 mm;

— rigid, so that it will not be deformed by more than 0,1 mm when an area of 100 mm² is loaded statically with 10 kg anywhere on the surface;

— sufficiently large to ensure the test package falls entirely upon the surface.

It shall have a mass at least 50 times that of the heaviest package to be tested.

NOTE — A concrete floor at least 150 mm thick is suitable provided it complies with the above requirements.

4.2 Means of loading, capable of applying a horizontal force to the vertical faces of the test package at a particular height above the centre of gravity and of sufficient force to cause toppling without causing the package to slide on the horizontal surface.

5 Package preparation

The test package shall normally be filled with its intended contents. However, under certain circumstances, simulated or dummy contents may be used on condition that the dimensions and physical properties of such contents shall be as close as possible to those of the intended contents.

Ensure that the test package is closed normally, as if ready for distribution. If simulated or dummy contents are used, ensure that the normal method of closure is still employed.

ISO 8768-1987 (E)

6 Conditioning

The package shall be conditioned in accordance with one of the conditions described in ISO 2233.

7 Procedure

Whenever possible the test shall be carried out in the same atmospheric conditions as used for conditioning, where this is critical to the materials or application of the package. In other circumstances, the test shall be carried out in atmospheric conditions which are as near as practicable to those used for conditioning.

7.1 Place the test package in the predetermined attitude (i.e. standing on one of its smaller faces) on the impact surface (4.1).

7.2 Using the means of loading provided (4.2), apply increasing force to a vertical face above the centre of gravity (or at an upper edge) so that the test package rotates about the opposite lower edge until a point of balance is reached. Then permit it to overbalance without thrust so that it falls freely onto the face opposite the face to which the force is applied.

NOTE — For smaller packages, which can be handled manually, the toppling force may be applied by hand. For larger packages, a mechanical means of loading may be necessary, i.e. a hydraulic ram or a cable or winch.

7.3 Examine the package and record any external signs of damage.

7.4 Repeat the test with the package standing on, or impacting onto, other appropriate faces. In the case of tall packages, the repeat tests shall be carried out with the package standing on its normal base and toppling onto each side face in turn (see figure 1). In the case of flat packages (or tall packages where the normal base is not defined), the tests shall be carried out with the package standing on each smaller face in turn and impacting onto each of the largest faces (see figure 2).

Tables 1 and 2 give appropriate sequences for tall packages and flat packages, respectively. For the designation of the faces referred to in the tables, see ISO 2206.

7.5 On completion of the test sequence, the test package and contents shall be examined for damage.

8 Test report

The test report shall include the following particulars :

- a) reference to this International Standard;
- b) number of replicate packages tested;
- c) full description of the package, including dimensions, structural and material specification of the package and its fittings, cushioning, blocking, closure or reinforcing arrangements;
- d) description of contents — if simulated or dummy contents were used, full details shall be given;
- e) gross mass of the package and mass of contents, in kilograms;
- f) relative humidity, temperature and time of conditioning; temperature and relative humidity of test area at time of test; whether these values comply with the requirements of ISO 2233;
- g) the sequence of attitudes in which the package was tested, using the method of identification given in ISO 2206; 998
- h) type of loading apparatus used and, if known, the height of the centre of gravity;
- i) any deviations from the test method described in this International Standard;
- j) a record of the result, with any observations which may assist in correct interpretation;
- k) date of the test;
- l) signature of tester.

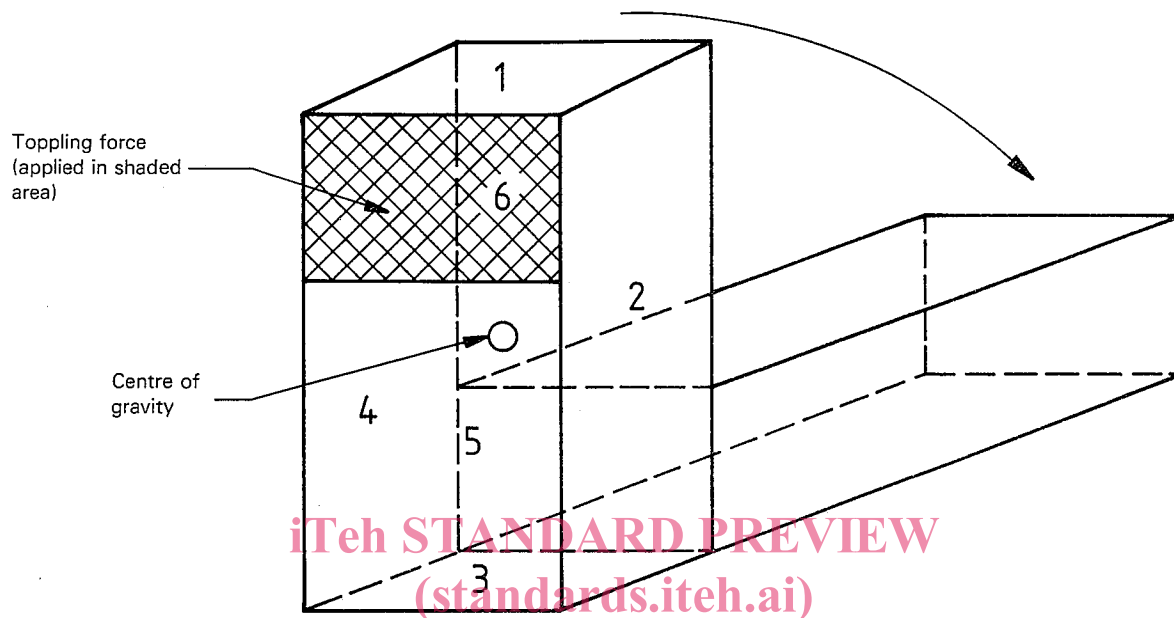

SIST EN 28768:1998
 Figure 1 – Testing of tall packages (i.e. where height is large compared with base dimensions)
<https://standards.iteh.ai/catalog/standards/sist/c9023431-54fb-8c00-4707-9984-c902343154fb/sist-en-28768-1998>

Table 1 – Test sequence for tall packages

Stand on face	Tilt over edge	Topple onto face
3	3-6	6
3	3-5	5
3	3-2	2
3	3-4	4
1*	1-6*	6*
1*	1-5*	5*
1*	1-2*	2*
1*	1-4*	4*

* This part of the sequence is only applied where the normal base is not defined.