



SLOVENSKI STANDARD
SIST EN 13247:2002
01-januar-2002

Embalaža - Podrobni opis povezovalnih trakov za dvigovanje, pritrjevanje in varovanje tovorov

Packaging - Specification for tensional strapping for lifting, lashing and securing of loads

Verpackung - Spezifikation für Umreifungsbänder aus Stahl zum Heben, Binden und Sichern von Ladungen

Emballage - Spécifications relatives aux cerclages d'acier pour le levage, l'arrimage et la fixation des charges

iTeh STANDARD PREVIEW
(standards.iteh.ai)

[SIST EN 13247:2002](https://standards.iteh.ai/catalog/standards/sist/644776ac-907a-4c13-969a-556a3167e601/sist-en-13247-2002)

Ta slovenski standard je istoveten z: EN 13247:2001

<https://standards.iteh.ai/catalog/standards/sist/644776ac-907a-4c13-969a-556a3167e601/sist-en-13247-2002>

ICS:

55.040 T e r a z a j a [[\ A æ Packaging materials and accessories
] æ ä æ b

SIST EN 13247:2002

en

iTeh STANDARD PREVIEW
(standards.iteh.ai)

SIST EN 13247:2002

<https://standards.iteh.ai/catalog/standards/sist/644776ac-907a-4c13-969a-356a3187e601/sist-en-13247-2002>

EUROPEAN STANDARD

EN 13247

NORME EUROPÉENNE

EUROPÄISCHE NORM

March 2001

ICS 55.040

English version

Packaging - Specification for tensional strapping for lifting, lashing and securing of loads

Emballage - Spécifications relatives aux cerclages d'acier
pour le levage, l'arrimage et la fixation des charges

Verpackung - Spezifikation für Umreifungsbänder aus Stahl
zum Heben, Binden und Sichern von Ladungen

This European Standard was approved by CEN on 4 February 2001.

CEN members are bound to comply with the CEN/CENELEC Internal Regulations which stipulate the conditions for giving this European Standard the status of a national standard without any alteration. Up-to-date lists and bibliographical references concerning such national standards may be obtained on application to the Management Centre or to any CEN member.

This European Standard exists in three official versions (English, French, German). A version in any other language made by translation under the responsibility of a CEN member into its own language and notified to the Management Centre has the same status as the official versions.

CEN members are the national standards bodies of Austria, Belgium, Czech Republic, Denmark, Finland, France, Germany, Greece, Iceland, Ireland, Italy, Luxembourg, Netherlands, Norway, Portugal, Spain, Sweden, Switzerland and United Kingdom.

SIST EN 13247:2002

<https://standards.iteh.ai/catalog/standards/sist/644776ac-907a-4c13-969a-356a3187e601/sist-en-13247-2002>



EUROPEAN COMMITTEE FOR STANDARDIZATION
COMITÉ EUROPÉEN DE NORMALISATION
EUROPÄISCHES KOMITEE FÜR NORMUNG

Management Centre: rue de Stassart, 36 B-1050 Brussels

iTeh STANDARD PREVIEW
(standards.iteh.ai)

SIST EN 13247:2002

<https://standards.iteh.ai/catalog/standards/sist/644776ac-907a-4c13-969a-356a3187e601/sist-en-13247-2002>

Foreword

iTeh STANDARD PREVIEW **(standards.iteh.ai)**

SIST EN 13247:2002

<https://standards.iteh.ai/catalog/standards/sist/644776ac-907a-4c13-969a-356a3187e601/sist-en-13247-2002>

iTeh STANDARD PREVIEW
(standards.iteh.ai)

SIST EN 13247:2002

<https://standards.iteh.ai/catalog/standards/sist/644776ac-907a-4c13-969a-356a3187e601/sist-en-13247-2002>

iTeh STANDARD PREVIEW
(standards.iteh.ai)

SIST EN 13247:2002

<https://standards.iteh.ai/catalog/standards/sist/644776ac-907a-4c13-969a-356a3187e601/sist-en-13247-2002>

iTeh STANDARD PREVIEW
(standards.iteh.ai)

SIST EN 13247:2002

<https://standards.iteh.ai/catalog/standards/sist/644776ac-907a-4c13-969a-356a3187e601/sist-en-13247-2002>

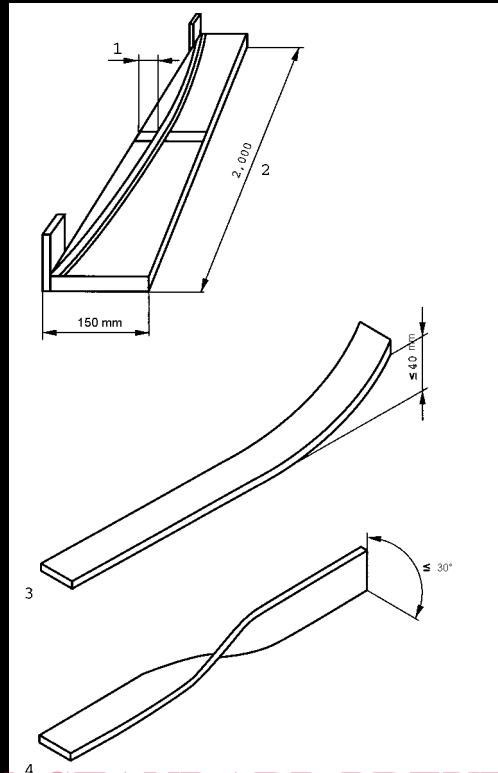

iTeh STANDARD PREVIEW
(standards.iteh.ai)

SIST EN 13247:2002

<https://standards.iteh.ai/catalog/standards/sist/644776ac-907a-4c13-969a-356a3187e601/sist-en-13247-2002>