

iTeh STANDARD PREVIEW
(standards.iteh.ai)

SIST EN 210:2000

<https://standards.iteh.ai/catalog/standards/sist/4af90c14-74e9-4d25-9b0b-b8ad9cb7d829/sist-en-210-2000>

English version

Steel drums - Non-removable head (tight head) drums with a
minimum total capacity of 216,5 lFûts en acier - Fûts à ouverture partielle d'une capacité
totale de 216,5 l minimumStahlfässer - Spundfässer mit einem Gesamtvolumen von
mindestens 216,5 l

This European Standard was approved by CEN on 23 October 1999.

CEN members are bound to comply with the CEN/CENELEC Internal Regulations which stipulate the conditions for giving this European Standard the status of a national standard without any alteration. Up-to-date lists and bibliographical references concerning such national standards may be obtained on application to the Central Secretariat or to any CEN member.

This European Standard exists in three official versions (English, French, German). A version in any other language made by translation under the responsibility of a CEN member into its own language and notified to the Central Secretariat has the same status as the official versions.

CEN members are the national standards bodies of Austria, Belgium, Czech Republic, Denmark, Finland, France, Germany, Greece, Iceland, Ireland, Italy, Luxembourg, Netherlands, Norway, Portugal, Spain, Sweden, Switzerland and United Kingdom.

ITeH STANDARD PREVIEW
(standards.iteh.ai)

SIST EN 210:2000

<https://standards.iteh.ai/catalog/standards/sist/4af90c14-74e9-4d25-9b0b-b8ad9cb7d829/sist-en-210-2000>



EUROPEAN COMMITTEE FOR STANDARDIZATION
COMITÉ EUROPÉEN DE NORMALISATION
EUROPÄISCHES KOMITEE FÜR NORMUNG

Central Secretariat: rue de Stassart, 36 B-1050 Brussels

CONTENTS

	Page
Foreword	3
1. Scope	4
2. Normative references	4
3. Terms and definitions	4
4. Dimensions	5
5. Material	5
6. Construction	5
7. Finish	6
8. Draining	6
9. Designation	6
Annex A (normative)	8
Capacity measurement method for non-removable head (tight head) steel drums	8
Annex B (normative)	10
Draining test method for non-removable head (tight head) steel drums	10
Figure 1 - Non-removable (tight head) drum with a minimum total capacity of 216,5 l	7
Figure B.1 — Determination of drainability	11

iTeh STANDARD PREVIEW
(standards.iteh.ai)

[SIST EN 210:2000](https://standards.iteh.ai/catalog/standards/sist/4af90c14-74e9-4d25-9b0b-b8ad9cb7db29/sist-en-210-2000)

<https://standards.iteh.ai/catalog/standards/sist/4af90c14-74e9-4d25-9b0b-b8ad9cb7db29/sist-en-210-2000>

ASTM INTERNATIONAL
1140 MARKET STREET, PHILADELPHIA, PA 19106
TEL: 610-670-1200 FAX: 610-670-1209
WWW.ASTM.ORG

Foreword

This European Standard has been prepared by Technical Committee CEN/TC 261 "Packaging", the secretariat of which is held by AFNOR.

This European Standard replaces EN 210:1986.

This European Standard shall be given the status of a national standard, either by publication of an identical text or by endorsement, at the latest by June 2000, and conflicting national standards shall be withdrawn at the latest by June 2000.

According to the CEN/CENELEC Internal Regulations, the national standards organizations of the following countries are bound to implement this European Standard: Austria, Belgium, Czech Republic, Denmark, Finland, France, Germany, Greece, Iceland, Ireland, Italy, Luxembourg, Netherlands, Norway, Portugal, Spain, Sweden, Switzerland and the United Kingdom.

This standard cancels and replaces EN 210:1986 in order to include drums with special dimensions for optimal loading of freight containers and drums with differently shaped tops for optimal draining.

This standard is one of a series of standards on steel drums of 17 l to 230 l and closures.

Efficient packaging is of great importance for the distribution and the protection of goods. Insufficient or inappropriate packaging can lead to damage or wastage of the contents of the package.

[SIST EN 210:2000](https://standards.iteh.ai/catalog/standards/sist/4af90c14-74e9-4d25-9b0b-b8ad9cb7d829/sist-en-210-2000)

<https://standards.iteh.ai/catalog/standards/sist/4af90c14-74e9-4d25-9b0b-b8ad9cb7d829/sist-en-210-2000>

1. Scope

This European Standard specifies the characteristics and dimensions of non-removable head (tight head) drums, manufactured from steel sheet, having a minimum total capacity of 216,5 l.

2. Normative references

This European Standard incorporates by dated or undated reference, provisions from other publications. These normative references are cited at the appropriate places in the text and the publications are listed hereafter. For dated references, subsequent amendments to or revisions of any of these publications apply to this European standard only when incorporated in it by amendment or revision. For undated references the latest edition of the publication referred to applies.

EN 10111:1998	Continuously hot-rolled low carbon steel sheet and strip for cold forming - Technical delivery conditions.
EN 10130+A1:1998	Cold rolled low carbon steel flat products for cold forming - Technical delivery conditions.
EN 10131:1991	Cold rolled uncoated low carbon and high yield strength steel flat products for cold forming - Tolerances on dimensions and shape.
prEN 12928:1999	Inserted flange type closure systems for steel drums with a total capacity of 17 l to 230 l.
EN ISO 90-2 : 1999	Light gauge metal containers - Definitions and determination of dimensions and capacities — Part 2: General use containers (ISO 90-2:1997).
ISO 228-1:1994	Pipe threads where pressure-tight joints are not made on the threads - Part 1 :Dimensions, tolerances and designation.
ISO 668:1995	Series 1 freight containers - Classification, dimensions and ratings.

3. Terms and definitions

For the purposes of this standard, the following terms and definitions apply.

3.1

non-removable head (tight head) drum (TH)

cylindrical packaging made of steel, the ends of which are permanently fixed to the body, with openings for filling, emptying and venting in the head

3.2

nominal capacity (NC)

capacity in litres which, by convention, is used to represent a class of drums of similar brimful capacities

3.3**brimful capacity (BC)**

volume of water in litres held by the drum when filled through the filling orifice to the point of overflowing

NOTE Annex A specifies the method for measuring brimful capacity.

3.4**total capacity (TC)**

volume of water in litres held by the drum when filled completely, i.e. following the removal of any air trapped in the drum

NOTE Annex A specifies the method for measuring total capacity.

4. Dimensions

The dimensions of non-removable (tight head) drums with a minimum total capacity of 216,5 l shall be as shown in Figure 1. In addition the steel thickness shall be between 0,6 mm and 1,5 mm, with tolerances as specified in EN 10131:1991 (normal tolerances). Manufacturing tolerances on overall height (*h*) shall be ± 3 mm.

5. Material

iTeh STANDARD PREVIEW
(standards.iteh.ai)

The body and ends of the drums shall be made of steel DC 01 in accordance with EN 10130+A1:1998, hot-rolled steel DD11 in accordance with EN 10111:1998, or steel of a higher strength. Closure flanges shall be manufactured from metal, and closure plugs from metal or plastics material as specified in prEN 12928:1999.

6. Construction

6.1 The longitudinal seam of the body shall be welded.

6.2 The body and ends shall be combined by round or triple seaming or other joining methods (e.g. welding).

6.3 The closures shall be in accordance with prEN 12928:1999 and shall be positioned in the top end of the drum, diametrically opposed, as indicated in Figure 1. The nominal pitch diameter and the pitch of the closures shall be as defined in ISO 228-1:1994, for threads G 3/4 and G2. The insertion of the closure with the G2 thread shall be such that its centre line is as close as possible to the vertical. The metal or plastics plugs shall be fitted with washers of suitable material compatible with the contents of the drum.

NOTE 1 In addition to the two rolling hoops (beads) as shown in Figure 1, the drum body may be reinforced with corrugations leaving a free space of at least 115 mm from the seams.

NOTE 2 Instead of a convex top, as shown in Figure 1, the drum can be fitted with a differently shaped top for optimal draining in an upside down position.

7. Finish

The nature of the internal and external finish shall be appropriate to the physical and chemical requirements of their intended use.

NOTE The nature of the internal and external finish should be agreed between the purchaser and the manufacturer.

8. Draining

8.1 The drum shall be designed so as to minimize the residual volume of the liquid left in the drum after drainage. The residue shall be not more than 100 ml when tested according to B.3 (procedure A)

8.2 The residue obtained when the drum is tested according to B.4 (procedure B) is more dependent on the area and condition of the internal surface of the drum than procedure A and therefore may be in excess of that for procedure A.

NOTE The maximum permitted figure should be agreed between the purchaser and the supplier.

9. Designation

iTeh STANDARD PREVIEW
(standards.iteh.ai)

A non-removable head (tight head) drum (TH) manufactured in accordance with EN 210 with a minimum total capacity of 216,5 l shall be designated:

Steel drum TH EN 210 TC-216,5 l.

NOTE Where the drums are intended to be used for the transport of dangerous goods, attention is drawn to the regulatory requirements which govern the transport of those goods in the countries concerned. In Europe, depending upon the mode of transport, this means meeting the requirements of:

European Agreement Concerning the International Carriage of Dangerous Goods by Road (ADR);

Regulations concerning the International Carriage of Dangerous Goods by Rail (RID);

Technical Instructions for the Safe Transport of Dangerous Goods by Air, Document 9284-AN/905 published by the Council of the International Civil Aviation Organization (ICAO);

The International Maritime Dangerous Goods Code (IMDG-CODE) published by the International Maritime Organization (IMO).

Dimensions in millimetres

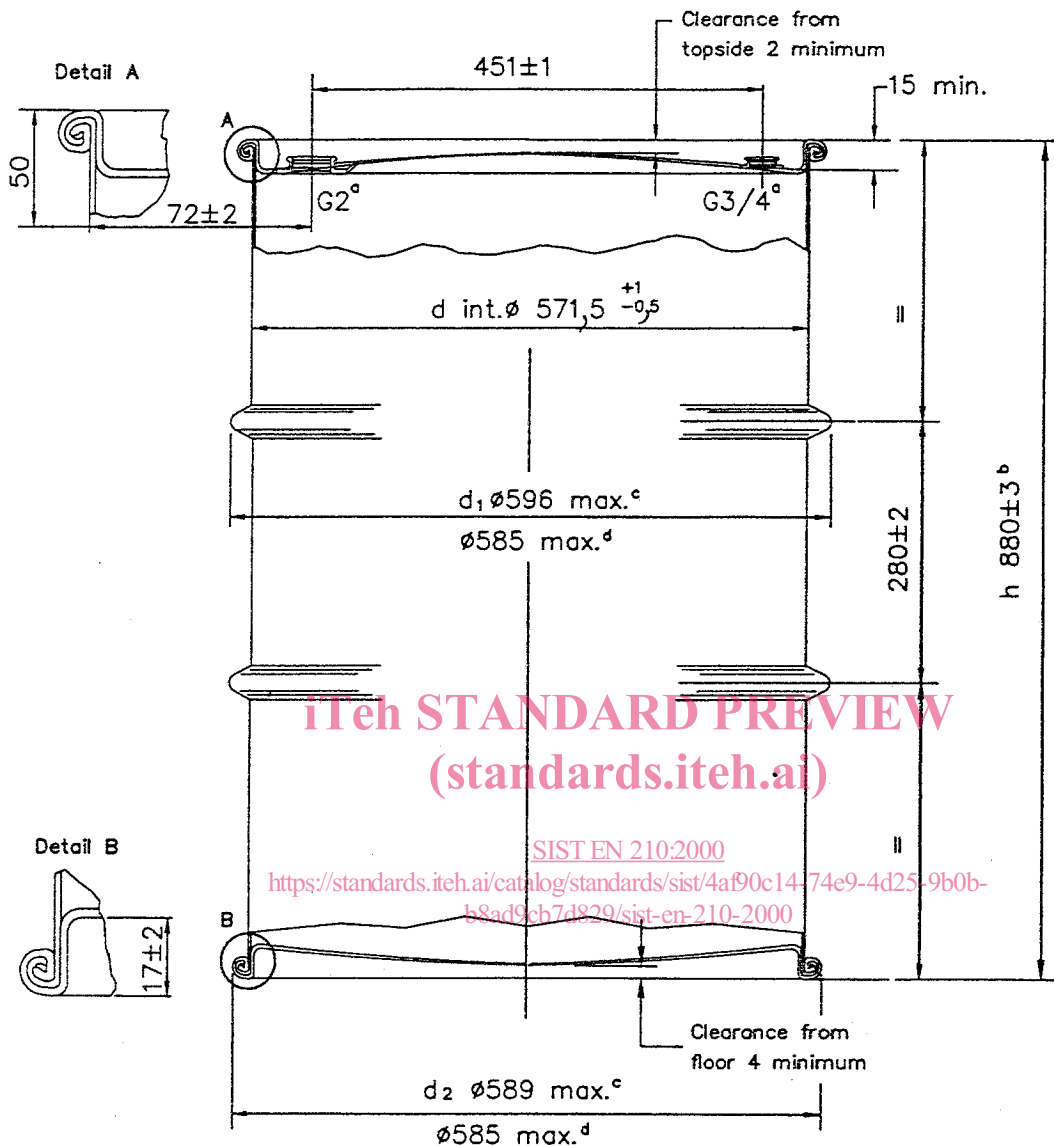

- ^a The complete closures (plugs and capseals) shall not protrude above the top seam.
- ^b The maximum overall height shall be 887 mm for drums having a concave formed top.
- ^c Diameter d_1 and diameter d_2 shall be 596 mm maximum and 589 mm maximum respectively on drums for general purpose.
- ^d Diameter d_1 and diameter d_2 shall be 585 mm maximum on drums for freight containers according to ISO 668:1995.

Figure 1 - Non-removable (tight head) drum with a minimum total capacity of 216,5 l