International Standard



6736

INTERNATIONAL ORGANIZATION FOR STANDARDIZATION • МЕЖДУНАРОДНАЯ ОРГАНИЗАЦИЯ ПО СТАНДАРТИЗАЦИИ • ORGANISATION INTERNATIONALE DE NORMALISATION

Dried milk — Determination of nitrate and nitrite contents — Method by cadmium reduction and photometry

Lait sec — Détermination des teneurs en nitrates et en nitrites — Méthode par réduction au cadmium et photométrie

First edition — 1982-12-01

ITeH STANDARD PREVIEW
(standards.iteh.ai)

[ISO 6736:1982](https://standards.iteh.ai/catalog/standards/sist/cc09a63a-02e7-4098-ab4d-173edfb4173c/iso-6736-1982)

<https://standards.iteh.ai/catalog/standards/sist/cc09a63a-02e7-4098-ab4d-173edfb4173c/iso-6736-1982>

UDC 637.143 : 543.242.8 : 546.173 / .175

Ref. No. ISO 6736-1982 (E)

Descriptors : agricultural products, dairy products, milk, dried milk, chemical analysis, determination of content, nitrates, nitrites, spectrophotometric analysis.

Foreword

ISO (the International Organization for Standardization) is a worldwide federation of national standards institutes (ISO member bodies). The work of developing International Standards is carried out through ISO technical committees. Every member body interested in a subject for which a technical committee has been set up has the right to be represented on that committee. International organizations, governmental and non-governmental, in liaison with ISO, also take part in the work.

Draft International Standards adopted by the technical committees are circulated to the member bodies for approval before their acceptance as International Standards by the ISO Council.

International Standard ISO 6736 was developed by Technical Committee ISO/TC 34, *Agricultural food products*, and was circulated to the member bodies in June 1981.

It has been approved by the member bodies of the following countries :

Australia	India	Romania
Austria	Iraq	South Africa, Rep. of
Belgium	Israel	Spain
Canada	Korea, Rep. of	Sri Lanka
Czechoslovakia	Netherlands	Tanzania
Egypt, Arab Rep. of	New Zealand	Thailand
Ethiopia	Peru	Turkey
France	Philippines	United Kingdom
Germany, F.R.	Poland	USSR
Hungary	Portugal	Yugoslavia

No member body expressed disapproval of the document.

Dried milk — Determination of nitrate and nitrite contents — Method by cadmium reduction and photometry

1 Scope and field of application

This International Standard specifies a method by cadmium reduction and photometry for the determination of the nitrate and nitrite contents of dried milk.

The method is suitable for whole, partly skimmed and skimmed milk powder.

NOTE — Methods for the determination of the nitrate and nitrite contents of whey cheese and dried whey are specified in ISO 6739 and ISO 6740 respectively.

2 Reference

ISO 707, *Milk and milk products — Methods of sampling*¹⁾

3 Definition

nitrate and nitrite contents of dried milk : The contents of substances determined by the procedure specified in this International Standard and expressed respectively as milligrams of nitrate ion (NO_3^-) and of nitrite ion (NO_2^-) per kilogram (parts per million).

4 Principle

Dissolution of the dried milk in water, precipitation of the fat and proteins, and filtration.

Reduction of the nitrate in a portion of the filtrate to nitrite, by means of copperized cadmium.

Development of a red colour, in portions of both unreduced filtrate and of the reduced solution, by addition of sulphanimide and *N*-1-naphthyl-ethylenediamine dihydrochloride, and photometric measurement at a wavelength of 538 nm.

Calculation of the nitrite content of the sample and of the total nitrite content after reduction of nitrate, by comparing the measured absorbances with those of a series of standard sodium nitrite solutions; calculation of the nitrate content from the difference between these two contents.

5 Reagents

All reagents shall be of recognized analytical quality. The water used shall be distilled or deionized water, free from nitrate and nitrite.

NOTE — In order to avoid possible inclusion of small gas bubbles in the copperized cadmium column (6.10), the distilled or deionized water used for the preparation of the column (8.1), for checking the reducing capacity of the column (8.2), and for regeneration of the column (8.3) should preferably be freshly boiled and afterwards cooled to room temperature.

5.1 Cadmium, granules, diameter 0,3 to 0,8 mm.

If cadmium granules are not available commercially, they may be prepared as follows.

Place a suitable number of zinc rods in a beaker and cover with a 40 g/l solution of cadmium sulphate octahydrate ($\text{CdSO}_4 \cdot 8\text{H}_2\text{O}$). From time to time, scrape the cadmium sponge from the rods over a period of 24 h. Remove the zinc rods and decant the liquid until only sufficient remains to cover the cadmium. Wash the sponge two or three times with distilled water. Transfer the cadmium to a laboratory blender together with 400 ml of 0,1 mol/l hydrochloric acid solution and blend for a few seconds to obtain granules of the required size. Return the contents of the blender to the beaker and leave to stand for several hours, occasionally stirring to remove bubbles. Decant most of the liquid and immediately copperize as described in 8.1.1 to 8.1.5.

5.2 Copper(II) sulphate solution.

Dissolve 20 g of copper(II) sulphate pentahydrate ($\text{CuSO}_4 \cdot 5\text{H}_2\text{O}$) in water and dilute to 1000 ml.

5.3 Buffer solution, pH 9,6 to 9,7.

Dilute 50 ml of concentrated hydrochloric acid [ρ_{20} 1,19 g/ml, about 38 % (*m/m*) solution] with 600 ml of water. After mixing, add 135 ml of ammonium hydroxide solution [ρ_{20} 0,91 g/ml, about 25 % (*m/m*) solution]. Dilute to 1000 ml with water and mix.

NOTE — If ammonium hydroxide solution of this concentration is not available, an equivalent amount of a more concentrated solution may be used, for example 100 ml of 35 % (*m/m*) solution (ρ_{20} 0,88 g/ml).

Adjust the pH to 9,6 to 9,7 if necessary.

5.4 Hydrochloric acid, about 2 mol/l solution.

Dilute 160 ml of concentrated hydrochloric acid (ρ_{20} 1,19 g/ml) to 1000 ml with water.

1) At present at the stage of draft. (Revision of ISO/R 707-1968.)

5.5 Hydrochloric acid, about 0,1 mol/l solution.

Dilute 50 ml of the hydrochloric acid solution (5.4) to 1000 ml with water.

5.6 Solutions for precipitation of proteins and fat.

5.6.1 Zinc sulphate solution.

Dissolve 53,5 g of zinc sulphate heptahydrate ($ZnSO_4 \cdot 7H_2O$) in water and dilute to 100 ml.

5.6.2 Potassium hexacyanoferrate(II) solution.

Dissolve 17,2 g of potassium hexacyanoferrate(II) trihydrate [$K_4Fe(CN)_6 \cdot 3H_2O$] in water and dilute to 100 ml.

5.7 EDTA solution.

Dissolve 33,5 g of *d*/sodium ethylenediaminetetraacetate dihydrate ($Na_2C_{10}H_{14}N_2O_8 \cdot 2H_2O$) in water and dilute to 1000 ml.

5.8 Solutions for colour development.

5.8.1 Solution I.

Dissolve, by heating on a water bath, 0,5 g of sulphanilamide ($NH_2C_6H_4SO_2NH_2$) in a mixture of 75 ml of water and 5 ml of concentrated hydrochloric acid (ρ_{20} 1,19 g/ml). Cool to room temperature and dilute to 100 ml with water. Filter if necessary.

5.8.2 Solution II.

Dilute 450 ml of concentrated hydrochloric acid (ρ_{20} 1,19 g/ml) to 1000 ml with water.

5.8.3 Solution III.

Dissolve 0,1 g of *N*-1-naphthyl-ethylenediamine dihydrochloride ($C_{10}H_7NHCH_2CH_2NH_2 \cdot 2HCl$) in water. Dilute to 100 ml with water. Filter if necessary.

The solution may be stored for up to 1 week in a well-stoppered brown bottle in a refrigerator.

5.9 Sodium nitrite, standard solution corresponding to 0,001 g of nitrite per litre.

On the day of use, dissolve in water 0,150 g of sodium nitrite ($NaNO_2$), dried to constant mass at 110 to 120 °C, dilute to 1000 ml with water in a one-mark volumetric flask and mix.

Dilute 10 ml of this solution with 20 ml of the buffer solution (5.3) and dilute further to 1000 ml with water in a one-mark volumetric flask. Mix.

1 ml of this standard solution contains 1,00 µg of NO_2^- .

5.10 Potassium nitrate, standard solution corresponding to 0,004 5 g of nitrate ion per litre.

Dissolve in water 1,468 g of potassium nitrate (KNO_3), dried to constant mass at 110 to 120 °C, dilute to 1000 ml with water in a one-mark volumetric flask and mix.

On the day of use, dilute 5 ml of this solution with 20 ml of the buffer solution (5.3) and dilute further to 1000 ml with water in a one-mark volumetric flask. Mix.

1 ml of this standard solution contains 4,50 µg of NO_3^- .

6 Apparatus

All glassware shall be thoroughly cleaned and rinsed with distilled water to ensure that it is free from nitrate and nitrite.

Usual laboratory apparatus, and in particular

6.1 Analytical balance.

6.2 Sample container, provided with an airtight lid.

6.3 Conical flasks, of capacity 250 ml.

6.4 Conical flask, of capacity 500 ml.

6.5 Volumetric flasks, of capacity 100 — 500 and 1000 ml, complying with the requirements of ISO 1042, class B.

6.6 Pipettes, to deliver 2 — 4 — 5 — 6 — 8 — 10 — 12 — 20 — 25 and 50 ml, complying with the requirements of ISO 648, class A, or ISO 835.

NOTE — Where appropriate, burettes may be used instead of pipettes.

6.7 Graduated cylinders, of capacity 5 — 10 — 25 — 100 — 250 — 500 and 1000 ml.

6.8 Glass funnels, of diameter about 7 cm, with short stem.

6.9 Filter paper, medium grade, of diameter about 15 cm, free from nitrate and nitrite.

6.10 Reduction column (for example as shown in the figure).

6.11 Photoelectric colorimeter or spectrophotometer, suitable for making readings at a wavelength of 538 nm, with cells of optical path length 1 to 2 cm.

7 Sampling

See ISO 707.

8 Procedure

8.1 Preparation of the copperized cadmium column

8.1.1 Transfer the cadmium granules (5.1) (approximately 40 to 60 g for each column) into a conical flask (6.3).

iTeh STANDARD PREVIEW

(standard.it) <https://standards.iteh.ai/catalog/standards/sist/cc09a63a-62e7-4698-ab4d-173edfb4173c/iso-6736-1982>

ISO 6736:1982

<https://standards.iteh.ai/catalog/standards/sist/cc09a63a-62e7-4698-ab4d-173edfb4173c/iso-6736-1982>

173edfb4173c/iso-6736-1982

8.1.2 Add sufficient of the hydrochloric acid solution (5.4) to cover the cadmium. Swirl for a few minutes.

8.1.3 Decant the solution and wash the cadmium in the flask with water, until it is free from chloride.

8.1.4 Copperize the cadmium granules by adding the copper(II) sulphate solution (5.2) (about 2,5 ml per gram of cadmium) and swirling for 1 min.

8.1.5 Decant the solution and wash the copperized cadmium immediately with water, taking care that the cadmium is continuously covered with water. Terminate the washing when the wash water is free from precipitated copper.

8.1.6 Fit a glass wool plug to the bottom of the glass column intended to contain the copperized cadmium (see the figure). Fill the glass column with water.

8.1.7 Transfer the copperized cadmium into the glass column with minimum exposure to air. The height of the copperized cadmium should be 15 to 20 cm.

NOTES

1 Avoid trapping air bubbles between the copperized cadmium granules.

2 Take care that the level of the liquid does not fall below the top of the copperized cadmium.

8.1.8 Condition the newly prepared column by running through it a mixture of 750 ml of water, 225 ml of the standard potassium nitrate solution (5.10), 20 ml of the buffer solution (5.3) and 20 ml of the EDTA solution (5.7), at a flow rate not exceeding 6 ml/min, then wash the column with 50 ml of water.

8.2 Checking the reducing capacity of the column

Carry out this check at least twice a day, at the beginning and at the end of a series of determinations.

8.2.1 Pipette 20 ml of the standard potassium nitrate solution (5.10) into the reservoir on top of the column. Immediately add 5 ml of the buffer solution (5.3) to the contents of the reservoir. Collect the eluate in a 100 ml volumetric flask. The flow rate shall not exceed 6 ml/min.

8.2.2 When the reservoir has nearly run empty, wash the walls of the reservoir with about 15 ml of water and, when this has run off, repeat the same treatment with another 15 ml portion of water. After this second portion of water has run into the column as well, completely fill the reservoir with water and allow it to pass through the column at maximum flow rate.

8.2.3 After nearly 100 ml of eluate has been collected, remove the volumetric flask, make up to the mark with water and mix well.

8.2.4 Pipette 10 ml of the eluate into a 100 ml volumetric flask. Add water to obtain a volume of about 60 ml. Proceed as specified in 8.8.2, 8.8.3 and 8.8.4.

8.2.5 From the nitrite content (in micrograms of nitrite ion per millilitre) of the diluted eluate (8.2.4), determined from the calibration curve (8.10), calculate the percentage reducing capacity of the column (0,067 μg of NO_2^- per millilitre corresponds to 100 % reducing capacity). If the reducing capacity is less than 95 %, the column should be regenerated.

8.3 Regeneration of the column

Regenerate the column as follows, at the end of each day after use, or more frequently if the check (8.2) indicates a loss of efficiency.

8.3.1 Add about 5 ml of the EDTA solution (5.7) and 2 ml of the hydrochloric acid solution (5.5) to 100 ml of water. Run the mixture through the column at a flow rate of about 10 ml/min.

8.3.2 When the reservoir has run empty, wash the column with water, the hydrochloric acid solution (5.5) and water successively.

8.3.3 If the column still does not show a satisfactory efficiency, repeat the procedure specified in 8.1.8.

8.4 Preparation of the test sample

Transfer the dried milk into a container of capacity about twice the volume of the powder, provided with an airtight lid. Close the container immediately. Mix the dried milk thoroughly by repeatedly shaking and inverting the container.

8.5 Test portion

Weigh, to the nearest 0,001 g, 10 g of the test sample and transfer it quantitatively into the conical flask (6.4).

8.6 Extraction and deproteination

8.6.1 Add gradually 112 ml of warm water (50 to 55 °C) to the test portion and dissolve the powder by stirring with a glass rod or by shaking the flask.

8.6.2 Add, in the following order, 24 ml of the zinc sulphate solution (5.6.1), 24 ml of the potassium hexacyanoferrate(II) solution (5.6.2) and 40 ml of the buffer solution (5.3), swirling thoroughly after each addition.

8.6.3 Leave for at least 15 min, but no longer than 1 h. Then filter through a filter paper (6.9), collecting the filtrate in a 250 ml conical flask.

NOTE — It is essential that the filtrate is clear and it may thus be necessary to leave the solution for more than 15 min to satisfy this requirement.

8.7 Reduction of nitrate to nitrite

8.7.1 Pipette 20 ml of the filtrate (8.6.3) into the reservoir on top of the reduction column. Add 5 ml of the buffer solution

(5.3) to the contents of the reservoir and mix by stirring with a small glass rod. Collect the eluate in a 100 ml volumetric flask. The flow rate shall not exceed 6 ml/min.

8.7.2 When the reservoir has nearly run empty, wash the walls of the reservoir with about 15 ml of water and, when this has run off, repeat the same treatment with another 15 ml portion of water. After this second portion of water has run into the column as well, completely fill the reservoir with water and allow it to flow through the column at maximum flow rate.

8.7.3 After nearly 100 ml of eluate has been collected, remove the volumetric flask, make up to the mark with water and mix well.

8.8 Determination

8.8.1 Pipette equal volumes (for example 25 ml) of the filtrate (8.6.3) and of the eluate (8.7.3) into separate 100 ml volumetric flasks. Add water to each to obtain a volume of about 60 ml. Then treat the contents of each flask as in 8.8.2, 8.8.3 and 8.8.4.

8.8.2 Add 6 ml of solution II (5.8.2) and then 5 ml of solution I (5.8.1). Mix carefully and leave the solution for 5 min at room temperature, protected from direct sunlight.

8.8.3 Add 2 ml of solution III (5.8.3). Mix carefully and leave the solution for 5 min at room temperature, protected from direct sunlight. Make up to the mark with water and mix well.

8.8.4 Measure within 15 min the absorbance of the solution against that of a reagents blank (8.9) at a wavelength of 538 nm.

8.9 Blank test

Carry out a reagents blank test using all the reagents, but omitting the test portion.

8.10 Calibration curve

8.10.1 Pipette 0 — 2 — 4 — 6 — 8 — 10 — 12 — 16 and 20 ml of the standard sodium nitrite solution (5.9) into separate 100 ml volumetric flasks. Add water to each volumetric flask to obtain volumes of about 60 ml.

8.10.2 Carry out the procedure described in 8.8.2 and 8.8.3.

8.10.3 Measure within 15 min the absorbances of the solutions against that of the first solution (containing no sodium nitrite) at a wavelength of 538 nm.

8.10.4 Plot the absorbances obtained in 8.10.3 against the nitrite concentrations, in micrograms per millilitre, calculated from the amounts of standard sodium nitrite solution added (see 8.10.1).

9 Expression of results

9.1 Nitrite content

9.1.1 Method of calculation and formula

The nitrite content of the sample, expressed as milligrams of nitrite ion (NO_2^-) per kilogram, is equal to

$$\frac{20\,000 \times c_1}{m \times V}$$

where

c_1 is the concentration, in micrograms of nitrite ion per millilitre, read from the calibration curve, corresponding to the measured absorbance (8.8.4) of the solution obtained using the filtrate (8.6.3);

m is the mass, in grams, of the test portion;

V is the volume, in millilitres, taken (8.8.1) from the filtrate (8.6.3).

Report the result to the nearest 0,1 mg/kg.

9.1.2 Repeatability

The difference between two results obtained within a short time-interval by the same analyst should not exceed 1 mg/kg.

9.2 Nitrate content

9.2.1 Method of calculation and formula

The nitrate content of the sample, expressed as milligrams of nitrate ion (NO_3^-) per kilogram, is equal to

$$1,35 \left(\frac{100\,000 \times c_2}{m \times V} - \text{NO}_2^- \right)$$

where

c_2 is the concentration, in micrograms of nitrite ion per millilitre, read from the calibration curve, corresponding to the measured absorbance (8.8.4) of the solution obtained using the eluate (8.7.3);

NO_2^- is the nitrite content of the sample, expressed in milligrams per kilogram, calculated as described in 9.1.1;

m is the mass, in grams, of the test portion;

V is the volume, in millilitres, taken (8.8.1) from the eluate (8.7.3).

NOTE — If the reducing capacity of the column is taken into account, the nitrate content of the sample, expressed as milligrams of nitrate ion per kilogram, is equal to

$$1,35 \left(\frac{100\,000 \times c_2}{m \times V} - \text{NO}_2^- \right) \frac{100}{r}$$

where r is the reducing capacity of the column at the end of a series of determinations.

Report the result to the nearest 1 mg/kg.

9.2.2 Repeatability

The difference between two results obtained within a short time-interval by the same analyst should not exceed 3 mg/kg if

the nitrate content is less than 30 mg/kg, and should not exceed 10 % of the arithmetic mean of the results if the nitrate content is greater than or equal to 30 mg/kg.

10 Test report

The test report shall show the method used and the results obtained. It shall also mention all operating conditions not specified in this International Standard, or regarded as optional, as well as any circumstances that may have influenced the results.

The test report shall include all the information necessary for the complete identification of the sample.

iTeh STANDARD PREVIEW (standards.iteh.ai)

ISO 6736:1982

<https://standards.iteh.ai/catalog/standards/sist/cc09a63a-02e7-4098-ab4d-173edfb4173c/iso-6736-1982>

Dimensions in millimetres

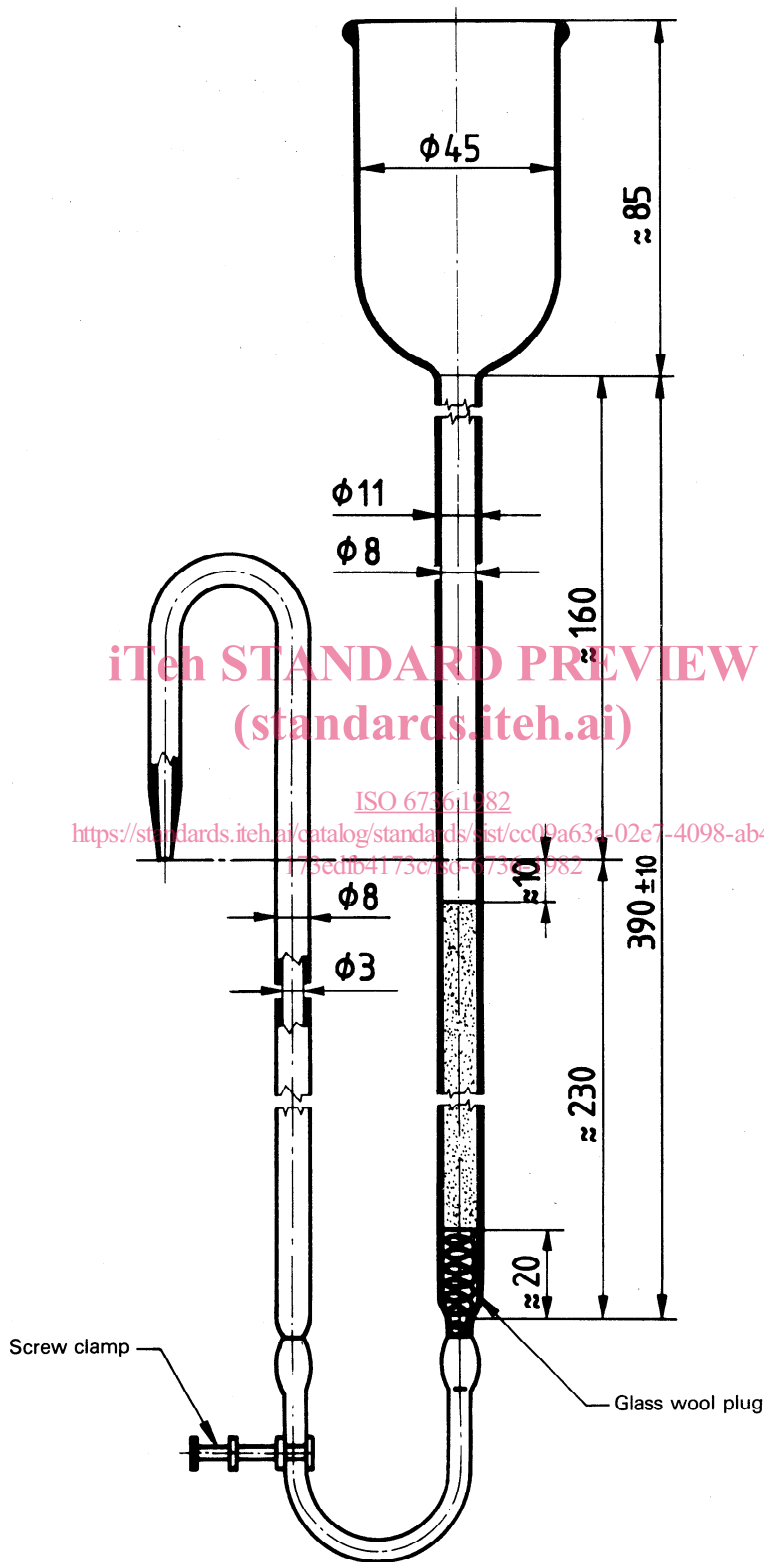

Figure — Apparatus for nitrate reduction