

# INTERNATIONAL STANDARD

ISO  
6739

Second edition  
1988-09-01



---

INTERNATIONAL ORGANIZATION FOR STANDARDIZATION  
ORGANISATION INTERNATIONALE DE NORMALISATION  
МЕЖДУНАРОДНАЯ ОРГАНИЗАЦИЯ ПО СТАНДАРТИЗАЦИИ

---

## Whey cheese — Determination of nitrate and nitrite contents — Method by cadmium reduction and spectrometry

**iTeh STANDARD PREVIEW**

*Fromage de sérum — Détermination des teneurs en nitrates et en nitrites — Méthode par réduction au cadmium et spectrométrie*

(standards.iteh.ai)

[ISO 6739:1988](https://standards.iteh.ai/catalog/standards/sist/65c894cb-de52-4136-8289-8e3d2a0b8014/iso-6739-1988)

<https://standards.iteh.ai/catalog/standards/sist/65c894cb-de52-4136-8289-8e3d2a0b8014/iso-6739-1988>

Reference number  
ISO 6739: 1988 (E)

## Foreword

ISO (the International Organization for Standardization) is a worldwide federation of national standards bodies (ISO member bodies). The work of preparing International Standards is normally carried out through ISO technical committees. Each member body interested in a subject for which a technical committee has been established has the right to be represented on that committee. International organizations, governmental and non-governmental, in liaison with ISO, also take part in the work. ISO collaborates closely with the International Electrotechnical Commission (IEC) on all matters of electrotechnical standardization.

Draft International Standards adopted by the technical committees are circulated to the member bodies for approval before their acceptance as International Standards by the ISO Council. They are approved in accordance with ISO procedures requiring at least 75 % approval by the member bodies voting.

International Standard ISO 6739 was prepared by Technical Committee ISO/TC 34, *Agricultural food products*, in collaboration with the International Dairy Federation (IDF) and the Association of Analytical Chemists (AOAC) and will also be published by these organizations.

This second edition cancels and replaces the first edition (ISO 6739 : 1982), of which it constitutes a minor revision.

# Whey cheese — Determination of nitrate and nitrite contents — Method by cadmium reduction and spectrometry

## 1 Scope

This International Standard specifies a method for the determination of the nitrate and nitrite contents of whey cheese.

The method is suitable for all kinds of whey cheese.

The detection limits of the method are 5 mg of nitrate per kilogram and 0,5 mg of nitrite per kilogram.

## 2 Normative reference

The following standard contains provisions which, through reference in this text, constitute provisions of this International Standard. At the time of publication, the edition indicated was valid. All standards are subject to revision, and parties to agreements based on this International Standard are encouraged to investigate the possibility of applying the most recent edition of the standard listed below. Members of IEC and ISO maintain registers of currently valid International Standards.

ISO 707 : 1985, *Milk and milk products — Methods of sampling*.

## 3 Definition

For the purposes of this International Standard, the following definition applies.

**nitrate and nitrite contents of whey cheese** : The mass fractions of substances determined by the procedure specified in this International Standard.

They are expressed respectively as milligrams of nitrate ion ( $\text{NO}_3^-$ ) and of nitrite ion ( $\text{NO}_2^-$ ) per kilogram.

## 4 Principle

Extraction of the whey cheese with warm water, precipitation of the fat and proteins, and filtration.

Reduction of the nitrate in a portion of the filtrate to nitrite, by means of copperized cadmium.

Development of a red colour, in portions of both the unreduced filtrate and the reduced solution, by addition of sulfanilamide and *N*-1-naphthyl-ethylenediamine dihydrochloride, and spectrometric measurement at a wavelength of 538 nm.

Calculation of the nitrite content of the sample and of the total nitrite content after reduction of nitrate, by comparing the measured absorbances with those of a series of standard sodium nitrite solutions; calculation of the nitrate content from the difference between these two contents.

## 5 Reagents

All reagents shall be of recognized analytical grade. The water used shall be distilled or deionized water, free from nitrate and nitrite.

NOTE — In order to avoid possible inclusion of small gas bubbles in the copperized cadmium column (6.11), the distilled or deionized water used for the preparation of the column (9.1), for checking the reducing capacity of the column (9.2) and for regeneration of the column (9.3) should preferably be freshly boiled and afterwards cooled to room temperature.

### 5.1 Cadmium, granules, of 0,3 mm to 0,8 mm diameter.

If cadmium granules are not available commercially, they may be prepared as follows.

Place a suitable number of zinc rods in a beaker and cover with a 40 g/l solution of cadmium sulfate octahydrate ( $\text{CdSO}_4 \cdot 8\text{H}_2\text{O}$ ). From time to time, scrape the cadmium sponge from the rods over a period of 24 h. Remove the zinc rods and decant the liquid until only sufficient remains to cover the cadmium. Wash the sponge two or three times with distilled water. Transfer the cadmium to a laboratory blender together with 400 ml of 0,1 mol/l hydrochloric acid solution and blend for a few seconds to obtain granules of the required size. Return the contents of the blender to the beaker and leave to stand for several hours, occasionally stirring to remove bubbles. Decant most of the liquid and immediately copperize as described in 9.1.1 to 9.1.5.

### 5.2 Copper(II) sulfate solution.

Dissolve 20 g of copper(II) sulfate pentahydrate ( $\text{CuSO}_4 \cdot 5\text{H}_2\text{O}$ ) in water and dilute to 1000 ml.

### 5.3 Buffer solution, pH 9,6 to 9,7.

Dilute 50 ml of concentrated hydrochloric acid [ $\rho_{20}$  1,19 g/ml, about 38 % (*m/m*) solution] with 600 ml of water. After mixing,

add 135 ml of ammonium hydroxide solution [ $\rho_{20}$  0,91 g/ml, about 25 % (m/m) solution]. Dilute to 1000 ml with water and mix.

NOTE — If ammonium hydroxide solution of this concentration is not available, an equivalent amount of a more concentrated solution may be used, for example 100 ml of 35 % (m/m) solution ( $\rho_{20}$  0,88 g/ml).

Adjust the pH to 9,6 to 9,7 if necessary.

**5.4 Hydrochloric acid**, about 2 mol/l solution.

Dilute 160 ml of concentrated hydrochloric acid ( $\rho_{20}$  1,19 g/ml) to 1000 ml with water.

**5.5 Hydrochloric acid**, about 0,1 mol/l solution.

Dilute 50 ml of the hydrochloric acid solution (5.4) to 1000 ml with water.

**5.6 Solutions for precipitation of proteins and fat.**

**5.6.1 Zinc sulfate solution.**

Dissolve 53,5 g of zinc sulfate heptahydrate ( $ZnSO_4 \cdot 7H_2O$ ) in water and dilute to 100 ml.

**5.6.2 Potassium hexacyanoferrate(II) solution.**

Dissolve 17,2 g of potassium hexacyanoferrate(II) trihydrate [ $K_4Fe(CN)_6 \cdot 3H_2O$ ] in water and dilute to 100 ml.

**5.7 EDTA solution.**

Dissolve 33,5 g of disodium ethylenediaminetetraacetate dihydrate ( $Na_2C_{10}H_{14}N_2O_8 \cdot 2H_2O$ ) in water and dilute to 1000 ml.

**5.8 Solutions for colour development.**

**5.8.1 Solution I.**

Dissolve, by heating on a water-bath, 0,5 g of sulfanilamide ( $NH_2C_6H_4SO_2NH_2$ ) in a mixture of 75 ml of water and 5 ml of concentrated hydrochloric acid ( $\rho_{20}$  1,19 g/ml). Cool to room temperature and dilute to 100 ml with water. Filter if necessary.

**5.8.2 Solution II.**

Dilute 450 ml of concentrated hydrochloric acid ( $\rho_{20}$  1,19 g/ml) to 1000 ml with water.

**5.8.3 Solution III.**

Dissolve 0,1 g of *N*-1-naphthyl-ethylenediamine dihydrochloride ( $C_{10}H_7NHCH_2CH_2NH_2 \cdot 2HCl$ ) in water. Dilute to 100 ml with water. Filter if necessary.

The solution may be stored for up to 1 week in a well-stoppered brown bottle in a refrigerator.

**5.9 Sodium nitrite**, standard solution corresponding to 0,001 g of nitrite ion per litre.

On the day of use, dissolve in water 0,150 g of sodium nitrite ( $NaNO_2$ ), dried to constant mass at 110 °C to 120 °C, dilute to 1000 ml with water in a one-mark volumetric flask and mix.

Dilute 10 ml of this solution with 20 ml of the buffer solution (5.3) and dilute further to 1000 ml with water in a one-mark volumetric flask. Mix.

1 ml of this standard solution contains 1,00 µg of  $NO_2^-$ .

**5.10 Potassium nitrate**, standard solution corresponding to 0,004 5 g of nitrate ion per litre.

Dissolve in water 1,468 g of potassium nitrate ( $KNO_3$ ), dried to constant mass at 110 °C to 120 °C, dilute to 1000 ml with water in a one-mark volumetric flask and mix.

On the day of use, dilute 5 ml of this solution with 20 ml of the buffer solution (5.3) and dilute further to 1000 ml with water in a one-mark volumetric flask. Mix.

1 ml of this standard solution contains 4,50 µg of  $NO_3^-$ .

**6 Apparatus**

All glassware shall be thoroughly cleaned and rinsed with distilled water to ensure that it is free from nitrate and nitrite.

Usual laboratory apparatus and, in particular, the following.

**6.1 Analytical balance.**

**6.2 Appropriate grinding device.**

**6.3 Sample container**, provided with an airtight lid.

**6.4 Suitable laboratory mixer/homogenizer**, with glass containers of 250 ml or 400 ml capacity.

**6.5 Conical flasks**, of 250 ml capacity.

**6.6 Volumetric flasks**, of 100, 500 and 1000 ml capacity, complying with the requirements of ISO 1042 : 1983, *Laboratory glassware — One-mark volumetric flasks*, class B.

**6.7 Pipettes**, to deliver 2, 4, 5, 6, 8, 10, 12, 20, 25 and 50 ml, complying with the requirements of ISO 648 : 1977, *Laboratory glassware — One-mark pipettes*, class A, or ISO 835 : 1981, *Laboratory glassware — Graduated pipettes*.

NOTE — Where appropriate, burettes may be used instead of pipettes.

**6.8 Graduated cylinders**, of 5, 10, 25, 100, 250, 500 and 1000 ml capacity.

**6.9 Glass funnels**, of diameter about 7 cm, with a short stem.

**6.10 Filter paper**, medium grade, of diameter about 15 cm, free from nitrate and nitrite.

**6.11 Reduction column** (for example as shown in figure 1).

**6.12 Spectrometer**, suitable for making readings at a wavelength of 538 nm, equipped with cells of 1 cm to 2 cm thickness.

## 7 Sampling

**7.1** Sampling shall be carried out in accordance with ISO 707.

**7.2** Store the sample in such a way that deterioration and change in its composition are prevented.

## 8 Preparation of the test sample

Grind the sample by means of an appropriate device (6.2); mix the ground mass quickly, and if possible grind a second time and again mix thoroughly. If the sample cannot be ground, mix it thoroughly by intensive stirring and kneading.

Transfer the test sample to an airtight container (6.3) to await analysis, which should be carried out as soon as possible after grinding. If delay is unavoidable, take all precautions to ensure proper preservation of the sample and to prevent condensation or moisture on the inside surface of the container. Ground cheese showing unwanted mould growth or the beginning of deterioration should not be examined.

Clean the device after grinding each sample.

## 9 Procedure

### 9.1 Preparation of the copperized cadmium column

**9.1.1** Transfer the cadmium granules (5.1) (approximately 40 g to 60 g for each column) into a conical flask (6.5).

**9.1.2** Add sufficient of the hydrochloric acid solution (5.4) to cover the cadmium. Swirl for a few minutes.

**9.1.3** Decant the solution and wash the cadmium in the flask with water, until it is free from chloride.

**9.1.4** Copperize the cadmium granules by adding the copper(II) sulfate solution (5.2) (about 2,5 ml per gram of cadmium) and swirling for 1 min.

**9.1.5** Decant the solution and wash the copperized cadmium immediately with water, taking care that the cadmium is continuously covered with water. Terminate the washing when the wash water is free from precipitated copper.

**9.1.6** Fit a glass wool plug to the bottom of the glass column intended to contain the copperized cadmium (see figure 1). Fill the glass column with water.

**9.1.7** Transfer the copperized cadmium into the glass column with minimum exposure to air. The height of the copperized cadmium should be 15 cm to 20 cm.

### NOTES

1 Avoid trapping air bubbles between the copperized cadmium granules.

2 Take care that the level of the liquid does not fall below the top of the copperized cadmium.

**9.1.8** Condition the newly prepared column by running through it a mixture of 750 ml of water, 225 ml of the standard potassium nitrate solution (5.10), 20 ml of the buffer solution (5.3) and 20 ml of the EDTA solution (5.7), at a flow-rate not exceeding 6 ml/min, then wash the column with 50 ml of water.

### 9.2 Checking the reducing capacity of the column

**9.2.1** Carry out this check at least twice a day, at the beginning and at the end of a series of determinations.

**9.2.2** Pipette 20 ml of the standard potassium nitrate solution (5.10) into the reservoir on top of the column. Immediately add 5 ml of the buffer solution (5.3) to the contents of the reservoir. Collect the eluate in a 100 ml volumetric flask. The flow-rate shall not exceed 6 ml/min.

**9.2.3** When the reservoir has nearly run empty, wash the walls of the reservoir with about 15 ml of water and, when this has run off, repeat the same treatment with another 15 ml portion of water. After this second portion of water has run into the column as well, completely fill the reservoir with water and allow it to pass through the column at maximum flow-rate.

**9.2.4** After nearly 100 ml of eluate has been collected, remove the volumetric flask, make up to the mark with water and mix well.

**9.2.5** Pipette 10 ml of the eluate into a 100 ml volumetric flask. Add water to obtain a volume of about 60 ml. Proceed as specified in 9.7.2, 9.7.3 and 9.7.4.

**9.2.6** From the nitrite content (in micrograms of nitrite ion per millilitre) of the diluted eluate (9.2.5), determined from the calibration curve (9.9), calculate the percentage reducing capacity of the column (0,067  $\mu\text{g}$  of  $\text{NO}_2^-$  per millilitre corresponds to 100 % reducing capacity). If the reducing capacity is less than 95 %, the column should be regenerated.

### 9.3 Regeneration of the column

**9.3.1** Regenerate the column as follows, at the end of each day after use, or more frequently if the check (9.2) indicates a loss of efficiency.

**9.3.2** Add about 5 ml of the EDTA solution (5.7) and 2 ml of the hydrochloric acid solution (5.5) to 100 ml of water. Run the mixture through the column at a flow-rate of about 10 ml/min.

**9.3.3** When the reservoir has run empty, wash the column with water, the hydrochloric acid solution (5.5) and water successively.

**9.3.4** If the column still does not show a satisfactory efficiency, repeat the procedure specified in 9.1.8.

**9.4 Test portion**

Weigh, to the nearest 0,001 g, approximately 5 g of the test sample and transfer it quantitatively into the glass container of the mixer/homogenizer (6.4).

**9.5 Extraction and deproteination**

**9.5.1** Add gradually 134 ml of warm water (50 °C to 55 °C) to the test portion. Mix in the mixer/homogenizer until the whey cheese is well suspended.

**9.5.2** Add, in the following order, 12 ml of the zinc sulfate solution (5.6.1), 12 ml of the potassium hexacyanoferrate(II) solution (5.6.2) and 40 ml of the buffer solution (5.3) to the whey cheese suspension, swirling thoroughly after each addition.

**9.5.3** Leave for at least 15 min, but no longer than 1 h. Then filter through a filter paper (6.10), collecting the filtrate in a 250 ml conical flask.

**NOTES**

- 1 The total volume of filtrate approximates to 200 ml and is regarded as such in the calculations (10.1.1 and 10.1.2).
- 2 To obtain a clear filtrate, it may be necessary to add (9.5.2) a larger volume of each precipitation solution (5.6.1 and 5.6.2), having reduced the volume of warm water (9.5.1) accordingly, so as to maintain the volume of filtrate at 200 ml.

**9.6 Reduction of nitrate to nitrite**

**9.6.1** Pipette 20 ml of the filtrate (9.5.3) into the reservoir on top of the reduction column. Add 5 ml of the buffer solution (5.3) to the contents of the reservoir and mix by stirring with a small glass rod. Collect the eluate in a 100 ml volumetric flask. The flow-rate shall not exceed 6 ml/min.

**9.6.2** When the reservoir has nearly run empty, wash the walls of the reservoir with about 15 ml of water and, when this has run off, repeat the same treatment with another 15 ml portion of water. After this second portion of water has run into the column as well, completely fill the reservoir with water and allow it to flow through the column at maximum flow-rate.

**9.6.3** After nearly 100 ml of eluate has been collected, remove the volumetric flask, make up to the mark with water and mix well.

**9.7 Determination**

**9.7.1** For nitrite determination, pipette an adequate volume (between 5 ml and 40 ml) of the filtrate (9.5.3) into a 100 ml volumetric flask. For nitrate determination pipette an adequate volume (between 5 ml and 40 ml) of the eluate (9.6.3) into another 100 ml volumetric flask. Add water to each to obtain a

volume of about 60 ml. Then treat the contents of each flask as in 9.7.2, 9.7.3 and 9.7.4.

**9.7.2** Add 6 ml of solution II (5.8.2) and then 5 ml of solution I (5.8.1). Mix carefully and leave the solution for 5 min at room temperature, protected from direct sunlight.

**9.7.3** Add 2 ml of solution III (5.8.3). Mix carefully and leave the solution for 5 min at room temperature, protected from direct sunlight. Make up to the mark with water and mix well.

**9.7.4** Measure within 15 min the absorbance of the solution against that of a reagents blank (9.8) at a wavelength of 538 nm.

**9.8 Blank test**

Carry out a reagents blank test using all the reagents, but omitting the test portion.

**9.9 Calibration curve**

**9.9.1** Pipette 0, 2, 4, 8, 10, 12 and 20 ml of the standard sodium nitrite solution (5.9) into separate 100 ml volumetric flasks. Add water to each volumetric flask to obtain volumes of about 60 ml.

**9.9.2** Carry out the procedure described in 9.7.2 and 9.7.3.

**9.9.3** Measure within 15 min the absorbances of the solutions against that of the first solution (containing no sodium nitrite) at a wavelength of 538 nm.

**10 Expression of results**

**10.1 Method of calculation**

**10.1.1 Nitrite content**

The nitrite content of the sample, expressed as milligrams of nitrite ion (NO<sub>2</sub><sup>-</sup>) per kilogram, is equal to

$$\frac{20\,000 \times c_1}{m \times V}$$

where

*c*<sub>1</sub> is the concentration, in micrograms of nitrite ion per millilitre, read from the calibration curve, corresponding to the measured absorbance (9.7.4) of the solution obtained using the filtrate (9.5.3);

*m* is the mass, in grams, of the test portion;

*V* is the volume, in millilitres, taken (9.7.1) from the filtrate (9.5.3).

Report the result to the nearest 0,1 mg/kg.

### 10.1.2 Nitrate content

The nitrate content of the sample, expressed as milligrams of nitrate ion ( $\text{NO}_3^-$ ) per kilogram, is equal to

$$1,35 \left( \frac{100\,000 \times c_2}{m \times V} - \text{NO}_2^- \right)$$

where

$c_2$  is the concentration, in micrograms of nitrite ion per millilitre, read from the calibration curve, corresponding to the measured absorbance (9.7.4) of the solution obtained using the eluate (9.7.1);

$\text{NO}_2^-$  is the nitrite content of the sample, expressed in milligrams per kilogram, calculated as described in 10.1.1;

$m$  is the mass, in grams, of the test portion;

$V$  is the volume, in millilitres, taken from the eluate (9.7.1).

NOTE — If the reducing capacity of the column is taken into account, the nitrate content of the sample, expressed as milligrams of nitrate ion per kilogram, is equal to

$$1,35 \left( \frac{100\,000 \times c_2}{m \times V} - \text{NO}_2^- \right) \frac{100}{r}$$

where  $r$  is the reducing capacity of the column at the end of a series of determinations.

Report the result to the nearest 1 mg/kg.

## 10.2 Precision

### 10.2.1 Nitrite

#### 10.2.1.1 Repeatability

The difference between two single results found on identical test material by one analyst using the same apparatus within a short time interval should not exceed 1 mg per kilogram of product.

#### 10.2.1.2 Limit of detection

The detection limit of the method is 0,5 mg of nitrite per kilogram.

### 10.2.2 Nitrate

#### 10.2.2.1 Repeatability

The difference between two single results found on identical test material by one analyst using the same apparatus within a short time interval should not exceed the following values :

5 mg per kilogram of product when the nitrate content is less than 30 mg/kg;

10 % of the arithmetic mean of the results when the nitrate content is greater than or equal to 30 mg/kg.

#### 10.2.2.2 Reproducibility

The difference between two single and independent results found by two operators working in different laboratories on identical test material should not exceed the following values :

10 mg per kilogram of product when the nitrate content is less than 30 mg/kg;

15 % of the arithmetic mean of the results when the nitrate content is greater than or equal to 30 mg/kg.

#### 10.2.2.3 Limit of detection

The detection limit of the method is 5 mg of nitrate per kilogram.

## 11 Test report

The test report shall specify the method used and the result obtained. It shall also mention all operating details not specified in this International Standard, or regarded as optional, together with details of any incidents which may have influenced the result.

The test report shall include all information necessary for the complete identification of the sample.

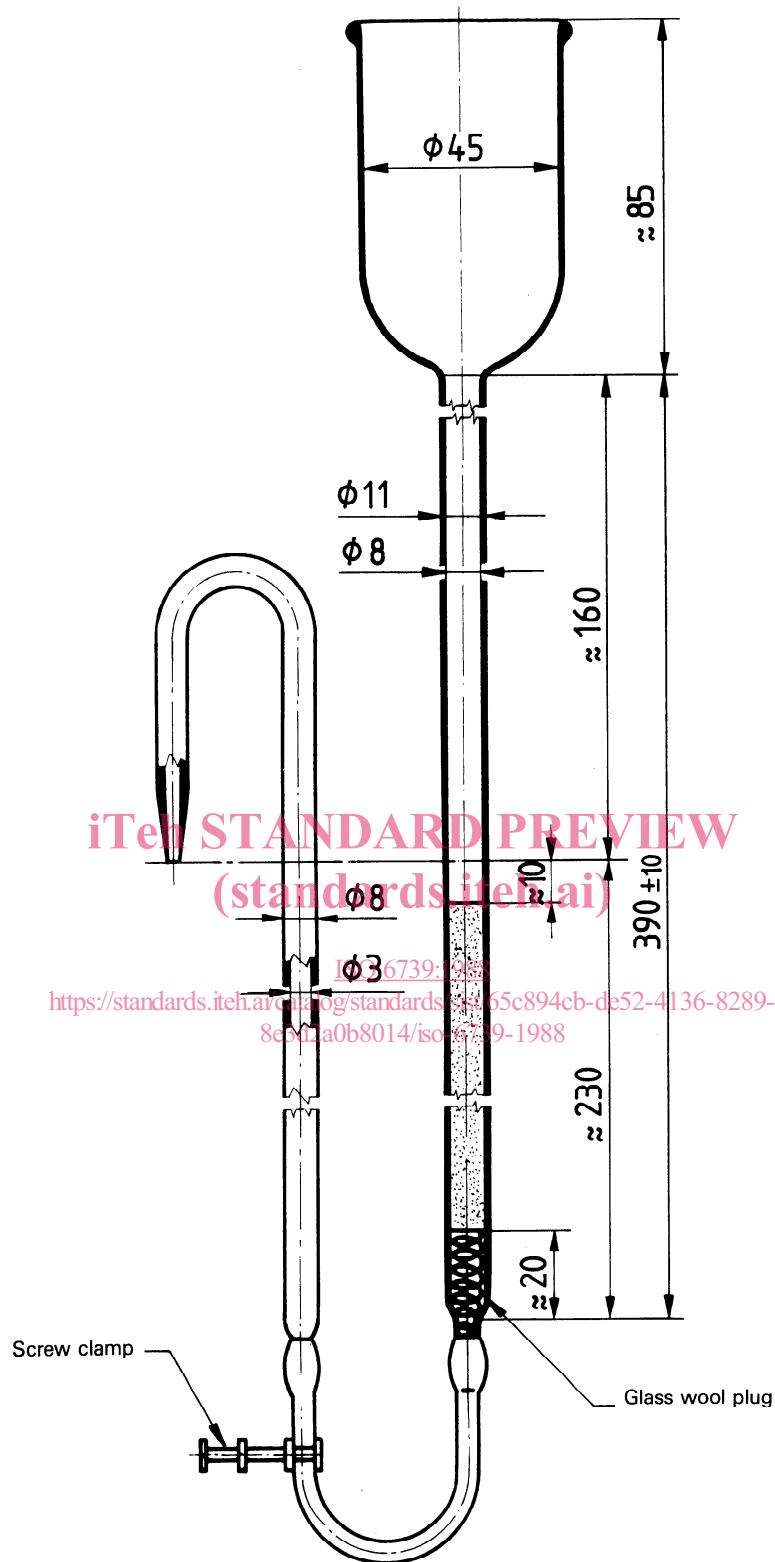

Figure 1 – Apparatus for nitrate reduction

UDC 637.344.6 : 543.42 : [546.173 + .175]

Descriptors : agricultural products, food products, dairy products, cheeses, chemical analysis, determination of content, nitrates, nitrites, spectrometric method.

Price based on 6 pages