International Standard



6742/2

INTERNATIONAL ORGANIZATION FOR STANDARDIZATION • МЕЖДУНАРОДНАЯ ОРГАНИЗАЦИЯ ПО СТАНДАРТИЗАЦИИ • ORGANISATION INTERNATIONALE DE NORMALISATION

**Cycles — Lighting and retro-reflective devices —
Photometric and physical requirements —
Part 2 : Retro-reflective devices**

Cycles — Éclairage et dispositifs rétro réfléchissants — Caractéristiques photométriques et physiques — Partie 2 : Dispositifs rétro réfléchissants

Second edition — 1985-07-15

(standards.iteh.ai)

ISO 6742-2:1985

<https://standards.iteh.ai/catalog/standards/sist/3e85b0f0-5a47-4fd6-888d-85bf80bf64bd/iso-6742-2-1985>

UDC 629.118.3.018.38

Ref. No. ISO 6742/2-1985 (E)

Descriptors : road vehicles, bicycles, lighting equipment, reflectors, cats eyes reflectors (vehicles), specifications, photometric properties, physical properties, colorimetric properties, tests, performance tests, marking

Preisgr. **E**

Price based on 8 pages

Foreword

ISO (the International Organization for Standardization) is a worldwide federation of national standards bodies (ISO member bodies). The work of preparing International Standards is normally carried out through ISO technical committees. Each member body interested in a subject for which a technical committee has been established has the right to be represented on that committee. International organizations, governmental and non-governmental, in liaison with ISO, also take part in the work.

Draft International Standards adopted by the technical committees are circulated to the member bodies for approval before their acceptance as International Standards by the ISO Council. They are approved in accordance with ISO procedures requiring at least 75 % approval by the member bodies voting.

International Standard ISO 6742/2 was prepared by Technical Committee ISO/TC 149, *Cycles*.

ISO 6742/2 was first published in 1984. This second edition cancels and replaces the first edition, of which it constitutes a minor revision in connection with the reflectors (clause 8.9.1).

ITeH STANDARD PREVIEW
(standards.iteh.ai)

<https://standards.iteh.ai/catalog/standards/sist/5c85b010-5a47-4fd6-888d-85bf80bf64bd/iso-6742-2-1985>

Contents

Page

0	Introduction	1
1	Scope and field of application	1
2	References	1
3	Definitions	1
4	Symbols and units used	2
5	Photometric requirements	3
6	Colorimetric requirements	4
7	Physical requirements	5
8	Photometric test for reflectors	6
9	Photometric test for retro-reflective tyres	8
10	Colorimetric test	8
11	Marking	8

iTeh STANDARD PREVIEW
(standards.iteh.ai)
ISO 6742-2:1985
<https://standards.iteh.ai/catalog/standards/sist/3e85b0f0-5a47-4fd6-888d-5b20184d1c1c/iso-6742-2:1985>

iTeh STANDARD PREVIEW
This page intentionally left blank
(standards.iteh.ai)

ISO 6742-2:1985

<https://standards.iteh.ai/catalog/standards/sist/3e85b0f0-5a47-4fd6-888d-85bf80bf64bd/iso-6742-2-1985>

Cycles — Lighting and retro-reflective devices — Photometric and physical requirements — Part 2 : Retro-reflective devices

iTeh STANDARD PREVIEW
(standards.iteh.ai)

0 Introduction

In producing this part of ISO 6742, the aim has been to specify requirements for retro-reflective devices fitted to cycles so that in conditions of poor visibility and at night, such devices are effective in helping to make all road users aware of the presence of a cyclist.

ISO 6742/1 specifies requirements for lighting equipment.

1 Scope and field of application

This part of ISO 6742 specifies photometric and physical requirements for retro-reflective devices for fitting to cycles intended to be used on public roads and, in particular, for use on cycles made in compliance with ISO 4210.

2 References

ISO 3768, *Metallic coatings — Neutral salt spray test (NSS test)*.

ISO 4210, *Cycles — Safety requirements of bicycles*.

IEC Publication No. 50(45), *International Electrotechnical Vocabulary — Lighting*.

CIE Publication No. 15, *Colorimetry : Official recommendations of the International Commission on Illumination (CIE)*.

3 Definitions

For the purposes of this part of ISO 6742, the definitions given below, together with those in IEC Publication No. 50(45) apply.

3.1 retro-reflective device; reflector : An assembly ready for use and comprising one or more retro-reflecting optical units.

3.2 wide angle reflector : Device providing retro-reflection through horizontal entrance angles of not less than 50° on either side of the reference axis.

3.3 conventional reflector : Device providing retro-reflection through horizontal entrance angles of not less than 20° on either side of the reference axis.

4 Symbols and units used (see figure 1)

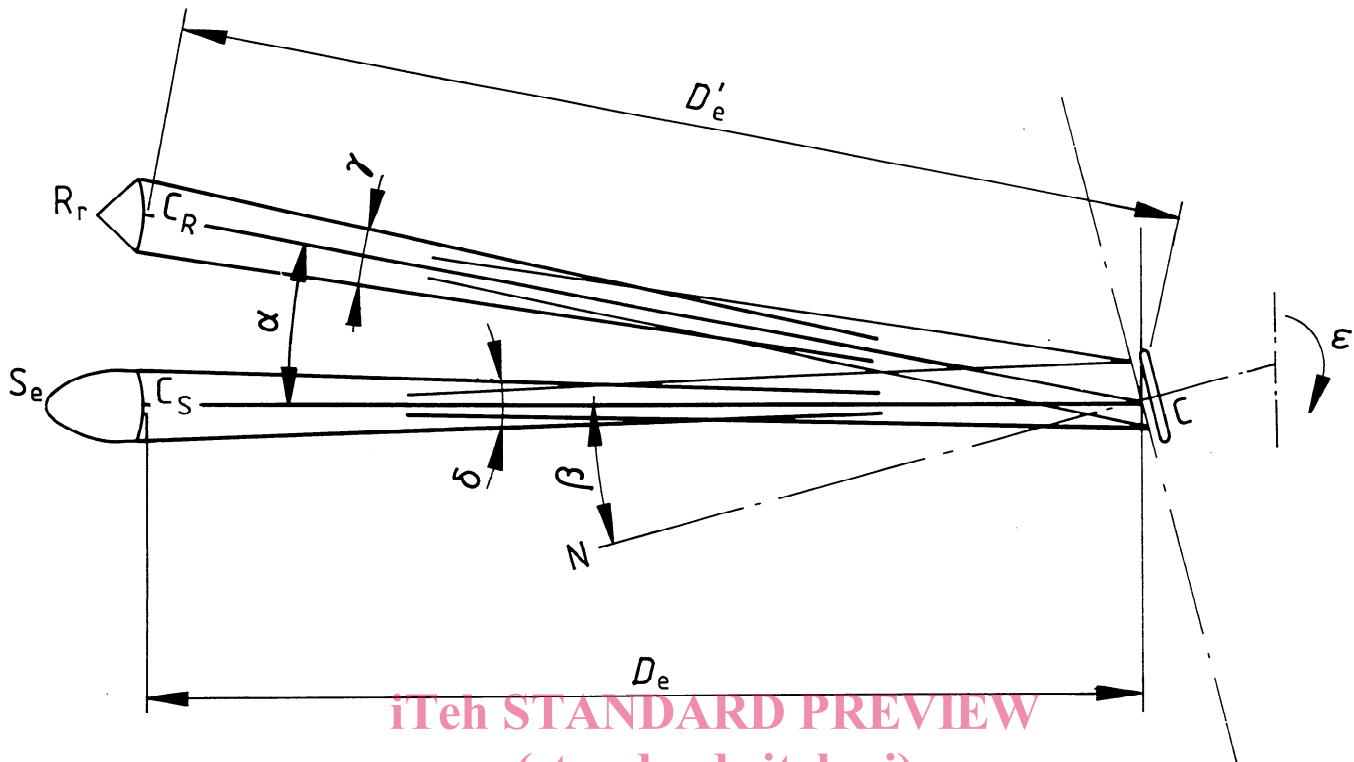

Figure 1 — Explanatory diagram of symbols used

NOTE — The following symbols are in accordance with regulation No. 3 of the UN/ECE concerning retro-reflecting devices.¹⁾

D_e — mean diameter of retro-reflective annulus on retro-reflective tyres, in millimetres.

A : area of the effective reflex surface of the retro-reflecting device, in square centimetres.

α : observation angle.

C : reference centre.

β : entrance angle. With respect to the line C_sC which is always considered to be horizontal, this angle is prefixed with signs — (left), + (right), + (up) or — (down), according to the position of the source S_e in relation to the axis NC , as seen when looking towards the retro-reflecting device. For any direction defined by two angles, vertical and horizontal, the vertical angle is always given first.

NC : reference axis.

R_r : receiver, observer or measuring device.

γ : angular subtense of the measuring device R_r , as seen from point C .

C_R : centre of receiver.

δ : angular subtense of the source S_e as seen from point C .

ϕ_R : diameter of receiver R_r , if circular, in centimetres.

S_e : source of illumination.

ϵ : rotation angle. This angle is positive when the rotation is clockwise as seen when looking towards the illuminated surface. If the reflecting device is marked 'TOP', the position thus indicated is taken as the origin.

C_s : centre of source of illumination.

ϕ_s : diameter of source of illumination, in centimetres.

D_e : distance from centre C_s to centre C , in metres.

D'_e : distance from centre C_R to centre C , in metres.

NOTE — All angles are expressed in degrees and minutes.

NOTE — D_e and D'_e are generally very nearly the same and under normal conditions of observation it may be assumed that $D_e = D'_e$. Furthermore, the effective distances may be used when a collimated system is used in order to obtain an artificially increased measuring distance.

E : illuminance of the retro-reflecting device, in lux.

CIL : coefficient of luminous intensity, in millicandelas per lux.

1) Document E/ECE 324 — E/ECE/TRANS/505 — Addendum 2/Revision 1, Regulation No. 3 : Uniform provisions concerning the approval of reflex reflecting devices for power-driven vehicles and their trailers.

5 Photometric requirements

5.1 Reflectors

When tested by the method given in clause 8, the CIL values for reflectors shall not be less than those specified in table 1 or 2.

Table 1 applies to front, side and rear reflectors. Values given are for clear (white) reflectors. Values for yellow reflectors shall

be $5/8 \times$ clear values. Values for red reflectors shall be $1/4 \times$ clear values.

Table 2 applies to pedal reflectors.

5.2 Retro-reflective tyres

When tested by the method given in clause 9, the CIL values for a retro-reflective tyre shall be not less than those specified in table 3. In the case where D is less than 420 mm the minimum photometric value for each observation and entrance angle shall be equal to the value for $D = 420$ mm.

Table 1 – Coefficients of luminous intensity, CIL, for clear reflectors

Observation angle, α°	Entrance angle, β°					
	Vertical : 0 Horizontal : 0	± 10 0	0 ± 20	0 ± 30	0 ± 40	0 ± 50
Either 0° 12' or 0° 20'	2 500	1 650	850	750	650	550
1° 30'	26	18	11	11	11	11

NOTE — Values for entrance angles of $\pm 30^\circ$, $\pm 40^\circ$ and $\pm 50^\circ$ are not applicable to conventional reflectors.

ISO 6742-2:1985

<https://standards.iteh.ai/catalog/standards/sist/3e85b0f0-5a47-4fd6-888d-85bf80bf64bd/iso-6742-2-1985>

Table 2 – Coefficients of luminous intensity, CIL, for yellow pedal reflectors

Observation angle, α°	Entrance angle, β°		
	Vertical : 0 Horizontal : 0	± 10 0	0 ± 20
Either 0° 12' or 0° 20'	450	350	175
1° 30'	16,5	11,5	7,5

Table 3 – Coefficients of luminous intensity, CIL, for retro-reflective tyres

Observation angle, α°	Entrance angle, β°			
	- 4°	20°	40°	50°
Either 0° 12' or 0° 20'	1,21 D	1,06 D	0,70 D	0,21 D
1° 30'	0,121 D	0,106 D	0,070 D	0,021 D

7 Physical requirements

7.1 Reflectors

7.1.1 Construction

The reflector and/or mount shall incorporate a distinct preferred assembly method to ensure that the reflector can be mounted in its designed orientation with regard to the bicycle.

7.1.2 Tests

7.1.2.1 General

A reflector shall comply with the photometric and colorimetric requirements of 5.1 and 6, and there shall be no loosening of the mounting(s) or distortion of the housing that would affect the performance of the reflector, after being subjected to any or all of the tests specified in 7.1.2.2 to 7.1.2.8.

7.1.2.2 Temperature resistance test

When tested by the following method, a reflector shall exhibit no noticeable defects :

Place the reflector in a pre-heated oven for a minimum period of 1 h at a temperature of 50 ± 5 °C.

NOTE — A pedal reflector may be tested integrally with its pedal.

7.1.2.3 Impact test

When a reflector is tested at room temperature by the following method the lens shall not crack :

Mount the reflector in a manner similar to the way in which it is mounted on the bicycle, but with the lens face horizontal and directed upwards.

Drop a 13 mm diameter polished solid steel ball, once, vertically onto the central part of the lens from a height of 0,76 m. The ball may be guided but not restricted in free fall.

NOTE — Pedal reflectors are exempt from this requirement.

7.1.2.4 Moisture resistance test

Strip all removable parts from the reflective device, whether part of a lamp or not, and immerse for 10 min in water at a temperature of 50 ± 5 °C, the highest point of the upper part of the reflective surface being 20 mm below the surface of the water. Repeat this test after turning the reflective device through 180° so that the reflective surface is at the bottom and the rear face is covered by about 20 mm of water. Then immediately immerse the optical unit in the same conditions in water at a temperature of 25 ± 5 °C.

7.1.2.5 Reflector mount alignment test

When tested by the following method, the optical axis of the reflector (excluding pedal reflectors or spoke-mounted reflectors) shall not deflect more than 15° during the test, and shall not exhibit a permanent displacement greater than 5° after the test.

With the reflector and mount assembled to a rigid fixture duplicating the mating component or frame member for which it is designed and intended for use (including a rigidly mounted bicycle), apply a force of 90 N to the reflector unit in at least three directions selected as most likely to affect its alignment.

7.1.2.6 Resistance to corrosion

After being tested by the method specified in ISO 3768 the reflector shall not exhibit any visible signs of corrosion liable to affect the integrity of the mounting or housing.

The duration of the test shall be 50 h comprising two periods of exposure of 24 h each, separated by an interval of 2 h during which the sample is allowed to dry.

7.1.2.7 Resistance to fuels

Soak the outer surface of the reflector in a mixture of 70 % of *n*-heptane and 30 % toluene (by volume). After 5 min clean the surface by washing in a detergent solution and rinse in clean water.

7.1.2.8 Resistance to lubricating oils

Wipe the outer surface of the reflex reflector lightly with cotton soaked in a detergent lubricating oil. After 5 min clean the surface by washing in a detergent solution and rinse in clean water.

7.2 Retro-reflective tyres

7.2.1 Form and location

The retro-reflective strip shall be in the form of a continuous circle of retro-reflective material on each sidewall of the tyre.

7.2.2 Tests

7.2.2.1 General

When subjected to the tests in 7.2.2.2 to 7.2.2.9 inclusive, the retro-reflective material on the tyre shall comply with the photometric requirements of 5.2 for $\alpha = 0^\circ 12'$ or $0^\circ 20'$ and $\beta = -4^\circ$, and with the colorimetric requirements of clause 6, as specified in table 5.

The table also indicates where a portion of a tyre shall be used instead of a complete tyre. The portion shall be cut from a tyre not previously subjected to the physical tests of this part of ISO 6742. The requirements of 5.2 and 6 do not apply to a portion cut from a tyre.