

---

International Standard



6746/2

---

INTERNATIONAL ORGANIZATION FOR STANDARDIZATION • МЕЖДУНАРОДНАЯ ОРГАНИЗАЦИЯ ПО СТАНДАРТИЗАЦИИ • ORGANISATION INTERNATIONALE DE NORMALISATION

---

**Earth-moving machinery — Definitions of dimensions and symbols —  
Part 2 : Equipment**

*Engins de terrassement — Définitions des dimensions et des symboles — Partie 2 : Équipement*

First edition — 1982-06-01

**iTeh STANDARD PREVIEW**  
**(standards.iteh.ai)**

ISO 6746-2:1982

<https://standards.iteh.ai/catalog/standards/sist/ae769e3a-4c34-4472-a91d-4f2a87a4ac57/iso-6746-2-1982>

---

UDC 621.878/.879 : 001.4

Ref. No. ISO 6746/2-1982 (E)

Descriptors : earth handling equipment, definitions.

Price based on 10 pages

## Foreword

ISO (the International Organization for Standardization) is a worldwide federation of national standards institutes (ISO member bodies). The work of developing International Standards is carried out through ISO technical committees. Every member body interested in a subject for which a technical committee has been set up has the right to be represented on that committee. International organizations, governmental and non-governmental, in liaison with ISO, also take part in the work.

Draft International Standards adopted by the technical committees are circulated to the member bodies for approval before their acceptance as International Standards by the ISO Council.

International Standard ISO 6746/2 was developed by Technical Committee ISO/TC 127, *Earth-moving machinery*, and was circulated to the member bodies in January 1980.

It has been approved by the member bodies of the following countries:

Austria	France	South Africa, Rep. of
Belgium	Germany, F.R.	Sweden
Brazil	Japan	United Kingdom
Bulgaria	Korea, Rep. of	USA
Canada	Pakistan	USSR
Chile	Poland	
Finland	Romania	

The member body of the following country expressed disapproval of the document on technical grounds:

Czechoslovakia

# Earth-moving machinery — Definitions of dimensions and symbols — Part 2 : Equipment

## iTeh STANDARD PREVIEW (standards.iteh.ai)

### 1 Scope

The plane is :

This part of ISO 6746 defines terms and symbols relating to dimensions of earth-moving machinery equipment.

a) for wheel machines, a hard level surface;

b) for crawler machines :

- 1) tractors — the lowest face of the shoe;
- 2) loaders — the bottom tip of the grouser.

### 2 Field of application

This part of ISO 6746 applies to the equipment of basic types of earth-moving machines as defined in ISO 6165.

### 3 References

ISO 6165, *Earth-moving machinery — Basic types — Vocabulary*.

ISO 6746/1, *Earth-moving machinery — Definitions of dimensions and symbols — Part 1 : Base machine*.

### 4 General definitions

For the purpose of this International Standard, the following definitions shall apply :

**4.1 three dimensional reference system** : See annex A.

**4.2 ground reference plane (GRP)** : The zero "Z" plane on which the machine is placed for the measurements.

### 5 General

In the annexes B, C, D and E are contained the symbols and the term definitions relating to dimensions of the equipment of earth-moving machines.

### 6 Coding system

Each dimension listed in the annexes B, C, D and E is assigned a code which is composed of :

**6.1** Two capital letters describing :

*HH* = height dimensions

*WW* = width dimensions

*LL* = length dimensions

*AA* = angle dimensions

**6.2** A number issued in sequence.

## Annex A

### Three-dimensional reference system — Definitions

#### 1 Scope

This annex defines the three-dimensional reference system used to determine dimensions of equipment of earth-moving machines.

The above system shall not be used for commercial documents.

#### 2 Field of application

This annex applies to the equipment of earth-moving machines as defined in ISO 6165.

#### 3 Definitions

**3.1 zero "Y" plane :** Vertical plane which passes through the longitudinal centre-line of the machine.

**3.2 "X" plane :** Any vertical plane normal to the "Y" plane.

**3.3 "Z" plane :** Any horizontal plane normal to the "X" and "Y" planes.

**3.4 positive coordinate :** The positive direction is forward of the zero "X" plane, right of the zero "Y" plane, and above the zero "Z" plane.

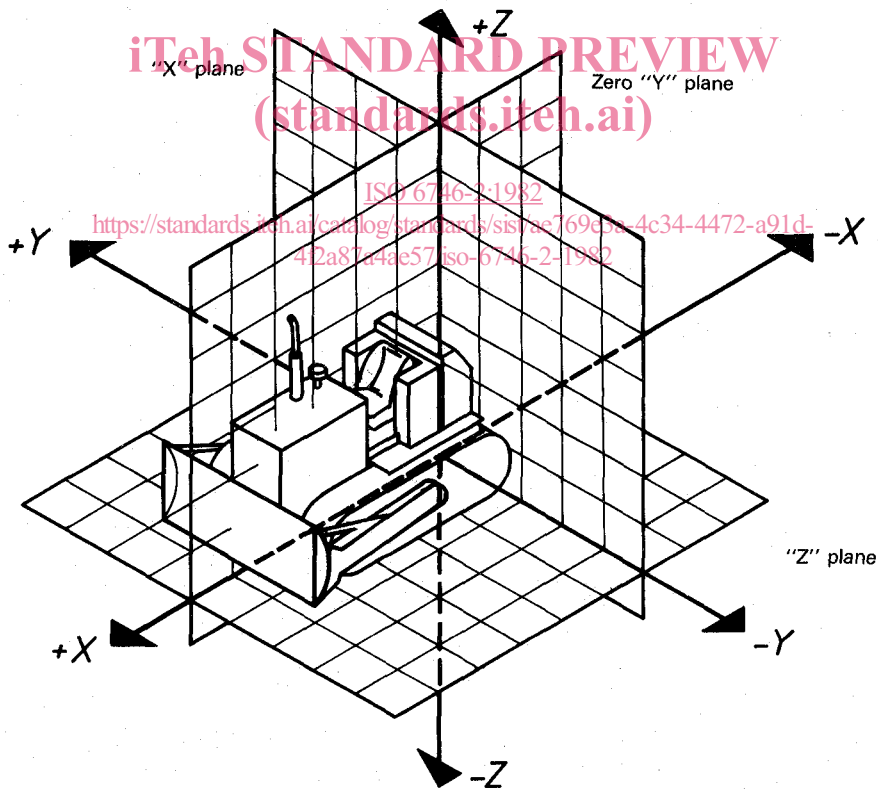

Figure 1 — Three-dimensional reference system

#### NOTES

1 The intersection of the X, Y, Z axes (zero planes) is normally located at well defined base point (i.e. SIP for a seat; crankshaft centre-line for an engine; sprocket or rear axle centre-line for a tractor; ground line for machine measurements).

2 If only equipment for a machine (i.e. dozer, ripper) are shown, the location and positive direction of the axis from the intersection of the X, Y, Z axes (zero planes) shall assume normally expected orientation of the equipment to a machine (i.e. the dozer cutting edge to the front of the machine, ripper to the rear).

3 If a machine and/or its equipment are shown, a machine driving from right to left shall be shown.

Annex B

Height dimensions – Terms and symbols

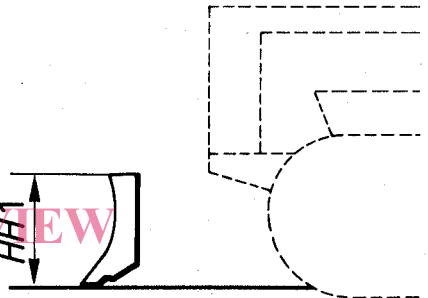
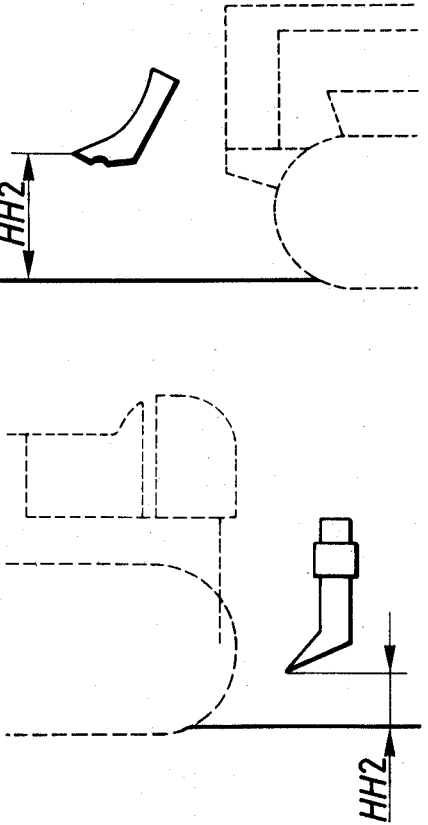
Symbol	Term	Definition	Drawing
<p><i>HH1</i></p>	<p>Blade height</p>	<p>Distance on "Z" coordinate between GRP and the top of the blade (excluding name plate and spill guard) with the blade on the ground in mid-pitch position with no blade tilt or angle.</p>	
<p><i>HH2</i></p>	<p>Lift height</p>	<p>Distance on "Z" coordinate between GRP and the centre of the cutting edge (in mid-pitch position with no blade tilt or angle) for blade or the lowest point for the ripper (in mid-pitch position) with the tooth in lifted position.</p>	

iTeh STANDARD PREVIEW  
(standards.iteh.ai)

ISO 6746-2:1982

<http://standards.iteh.ai/catalog/standards/sist/c769e3a-4c34-4472-a91d-42e8744e5764/iso-6746-2-1982>

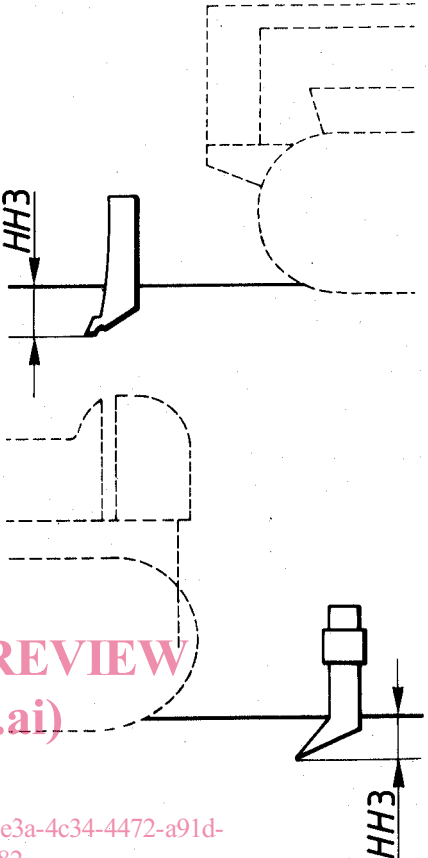
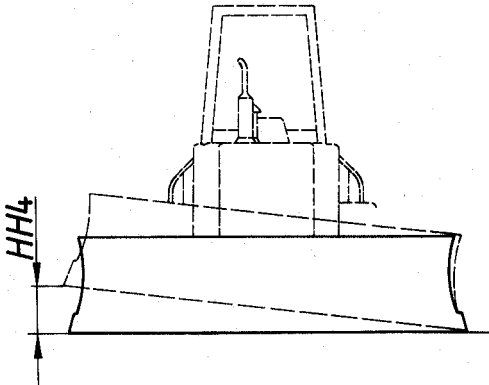
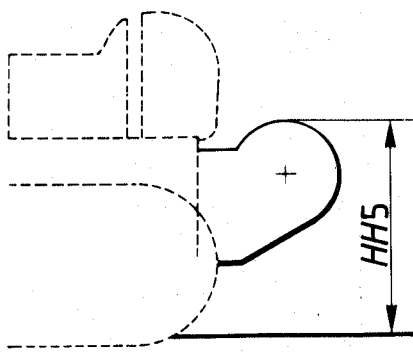
Symbol	Term	Definition	Drawing
<p><i>HH3</i></p>	<p>Cutting depth</p>	<p>Distance on "Z" coordinate between GRP and the centre of the cutting edge (in mid-pitch position with no plade tilt or angle) for blade or the lowest point for the ripper with the tooth below ground.</p>	 <p>The drawing illustrates the measurement of cutting depth (HH3) for two types of tools. The top part shows a blade with a cutting edge; a horizontal line represents the ground level (GRP), and a vertical double-headed arrow labeled HH3 indicates the distance from this line to the center of the cutting edge. The bottom part shows a ripper tooth with a rounded tip; a horizontal line represents the GRP, and a vertical double-headed arrow labeled HH3 indicates the distance from this line to the lowest point of the tooth's tip.</p>
<p><i>HH4</i></p>	<p>Tilt height</p>	<p>Distance on "Z" coordinate between GRP and the end bit. If opposite ends vary, specify both.</p>	 <p>The drawing shows a ripper assembly with a tilted blade. A horizontal line represents the ground level (GRP). A vertical double-headed arrow labeled HH4 indicates the distance from the GRP to the top of the end bit of the ripper.</p>
<p><i>HH5</i></p>	<p>Winch Maximum height</p>	<p>Distance on "Z" coordinate between the GRP and the highest point of the winch.</p>	 <p>The drawing shows a ripper with a winch mechanism. A horizontal line represents the ground level (GRP). A vertical double-headed arrow labeled HH5 indicates the distance from the GRP to the highest point of the winch.</p>

iTeh STANDARD PREVIEW  
(standards.iteh.ai)

ISO 6746-2:1982

<https://standards.iteh.ai/catalog/standards/sist/ae769e3a-4c34-4472-a91d-4f2a87a4ae57/iso-6746-2-1982>

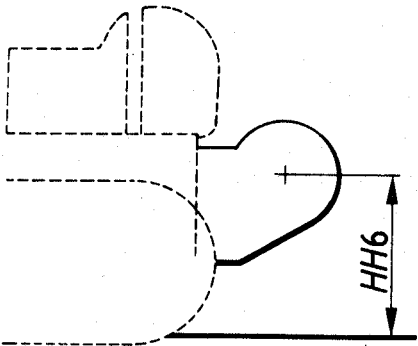
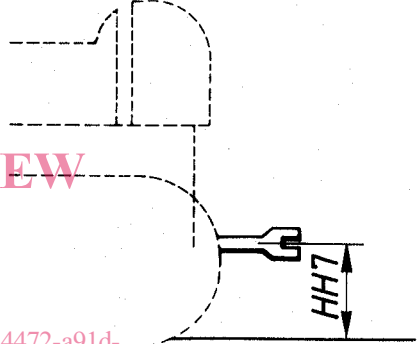
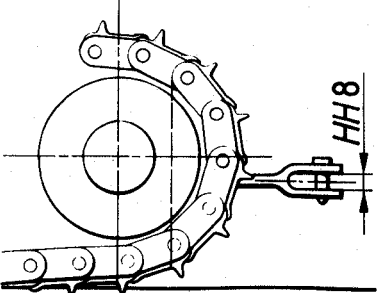
Symbol	Term	Definition	Drawing
HH6	Winch Centre of drum height	Distance on "Z" coordinate between the GRP and the centre of drum.	
HH7	Drawbar height	Distance on "Z" coordinate between the GRP and the centre-line of the drawbar clevis (fork).	
HH8	Clevis width	Distance on "Z" coordinate between two "Z" planes passing through the inside surface of the drawbar clevis (fork).	

iTeh STANDARD PREVIEW  
(standards.iteh.ai)

ISO 6746-2:1982

<https://standards.iteh.ai/catalog/standards/sist/ae769e3a-4c34-4472-a91d-4f2a87a4ac57/iso-6746-2-1982>

### Annex C

### Width dimensions – Terms and symbols

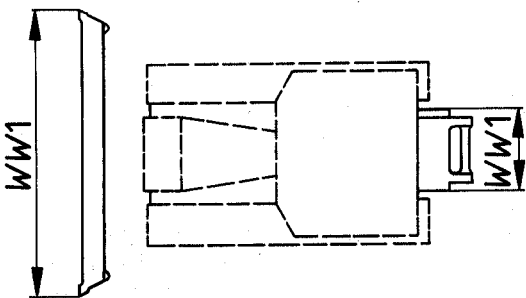
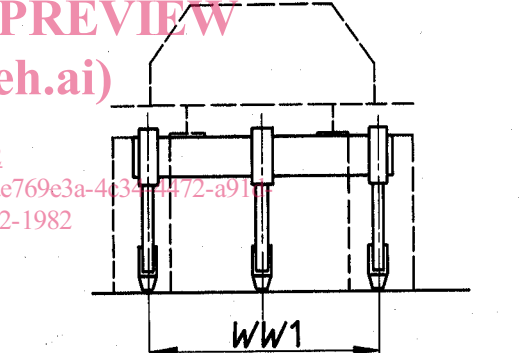
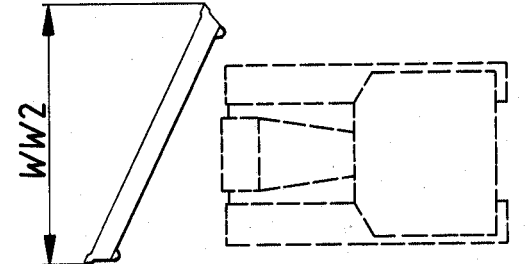
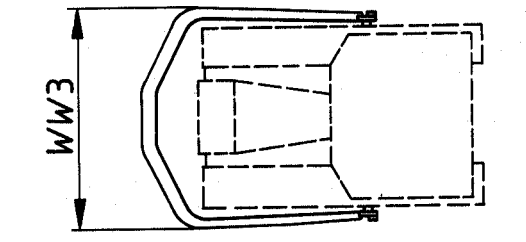
Symbol	Term	Definition	Drawing
WW1	Maximum width	Distance on "Y" coordinate between two "Y" planes passing through the farthest points of the equipment.	 <p style="text-align: center; color: red; font-weight: bold;">iTeh STANDARD PREVIEW (standards.iteh.ai)</p> <p style="text-align: center; color: red; font-size: small;">ISO 6746-2:1982 <a href="https://standards.iteh.ai/catalog/standards/sist/ae769e3a-4634-4472-a911-4f2a87a4ac57/iso-6746-2-1982">https://standards.iteh.ai/catalog/standards/sist/ae769e3a-4634-4472-a911-4f2a87a4ac57/iso-6746-2-1982</a></p> 
WW2	Angle blade width	Distance on "Y" coordinate between two "Y" planes passing through the farthest points of the blade when the blade is at the maximum angle.	
WW3	C-frame width	Distance on "Y" coordinate between two "Y" planes passing through the farthest points of the C-frame.	

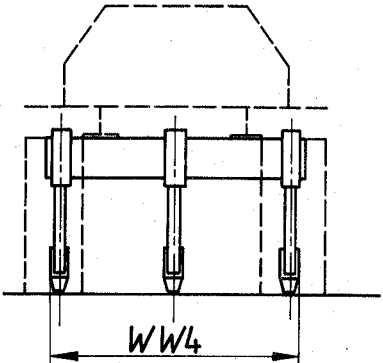
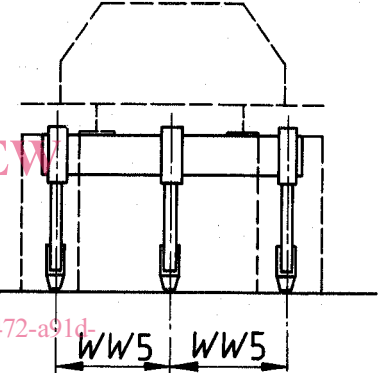

Symbol	Term	Definition	Drawing
WW4	Shanks working width	Distance on "Y" coordinate between two "Y" planes passing through the outermost points of the teeth of the external shanks.	 <p>The drawing shows a top-down view of a three-shank tool bit. A horizontal dimension line with arrows at both ends spans the distance between two vertical dashed lines. These dashed lines are positioned at the outermost points of the teeth of the left and right shanks. The dimension is labeled 'WW4'.</p>
WW5	Shanks centre distance	Distance on "Y" coordinate between the centre-line of two adjoining shanks.	 <p>The drawing shows a top-down view of a three-shank tool bit. Two horizontal dimension lines with arrows at both ends are shown. Each dimension line spans the distance between the vertical center-lines of two adjacent shanks. The dimensions are labeled 'WW5'.</p>

iTeh STANDARD PREVIEW  
(standards.iteh.ai)

ISO 6746-2:1982

<https://standards.iteh.ai/catalog/standards/sist/ae769e3a-4c34-4472-a91d-4f2a87a4ac57/iso-6746-2-1982>