



Designation: F 1821 – 97

Standard Consumer Safety Specification for Toddler Beds¹

This standard is issued under the fixed designation F 1821; the number immediately following the designation indicates the year of original adoption or, in the case of revision, the year of last revision. A number in parentheses indicates the year of last approval. A superscript epsilon (ϵ) indicates an editorial change since the last revision or reapproval.

INTRODUCTION

This consumer safety specification addresses toddler bed incidents that were identified by the Consumer Product Safety Commission (CPSC).

In response to incident data supplied by the commission, this consumer safety specification attempts to minimize: entrapment in bed end structures, entrapment between the guardrail and side rail, and entrapment in the mattress support system. Entrapment of a child's head or neck can result in asphyxiation.

This consumer safety specification is written in accordance with the current available state-of-the-art technology and will be updated whenever substantive information becomes available that necessitates additional requirements or justifies a revision to existing requirements.

1. Scope

1.1 This consumer safety specification covers requirements for the design and performance of toddler beds. It also contains requirements for labeling and instructional material.

1.2 This consumer safety specification is intended to minimize incidents to children resulting from normal use and reasonably foreseeable misuse of toddler beds. It does not address incidents resulting from alteration or unreasonable misuse.

1.3 For the purposes of this consumer safety specification, a toddler bed is a bed that is sized to accept a full-size crib mattress and is intended for use by a child not less than 15 months of age and who weighs no more than 50 lb (22.7 kg).

1.4 No toddler bed produced after the approval date of this consumer safety specification shall indicate compliance with this specification, either by label or by other means, unless it conforms to all the requirements contained herein.

1.5 The values stated in inch-pound units are to be regarded as the standard. The SI values given in parentheses are for information only.

1.6 The following safety hazards caveat pertains only to the test methods portion, Section 7, of this consumer safety specification: *This standard does not purport to address all of the safety concerns, if any, associated with its use. It is the responsibility of the user of this standard to establish appropriate safety and health practices and determine the applicability of regulatory limitations prior to use.*

¹ This consumer safety specification is under the jurisdiction of ASTM Committee F-15 on Consumer Products and is the direct responsibility of Subcommittee F15.18 on Cribs, Toddler Beds, and Play Yards.

Current edition approved Oct. 10, 1997. Published August 1998.

2. Referenced Documents

2.1 ASTM Standards:

F 966 Consumer Safety Specification for Full-Size and Non-Full-Size Baby Crib Corner Post Extensions²

2.2 Code of Federal Regulations:

16 CFR 1303 Ban of Lead-Containing Paint and Certain Consumer Products Bearing Lead-Containing Paint³

16 CFR 1500 Hazardous Substances Act Regulations, including the following sections:

16 CFR 1500.48 Technical Requirements for Determining a Sharp Point in Toys and Other Articles Intended for Children Under 8 Years of Age³

16 CFR 1500.49 Technical Requirements for Determining a Sharp Metal or Glass Edge in Toys and Other Articles Intended for Children Under 8 Years of Age³

16 CFR 1500 .50 - .53 Test Method for Simulating Use And Abuse of Toys and Other Articles Intended for Use By Children³

16 CFR 1501 Method for Identifying Toys and Other Articles Intended for Use by Children Under 3 Years of Age Which Present Choking, Aspiration or Ingestion Hazards Because of Small Parts³

3. Terminology

3.1 Definitions of Terms Specific to This Standard:

3.1.1 *bed, n*—for the purpose of this specification, a toddler bed, as described in 3.1.2.

² Annual Book of ASTM Standards, Vol 15.07.

³ Available from Superintendent of Documents, U.S. Government Printing Office, Washington, DC 20402.

3.1.2 *bed, toddler, n*—for the purpose of this specification, any bed sized to accommodate a full-size crib mattress having minimum dimensions of 51 5/8 in. (1310 mm) in length and 27 1/4 in. (690 mm) in width and is intended to provide free access and egress to a child not less than 15 months of age and who weighs no more than 50 pounds (22.7 kg).

3.1.3 *end structure, n*—an upright structure at the head or foot of a bed to which the side rails or mattress support system, or both, attach.

3.1.4 *guardrail, n*—of a bed, a rail attached to a bed intended to help prevent a sleeping occupant from rolling, sliding, or otherwise falling out of the long side of the bed.

3.1.5 *mattress support system, n*—those components of a bed structure that support the mattress.

3.1.6 *permanent marking, n*—a marking or label that, during an attempt to remove it manually without the aid of tools or solvents, cannot be removed or tears upon removal, or such action damages the surface to which it is attached.

3.1.7 *side rail, n*—the structure connecting the end structures.

4. General Requirements

4.1 The bed shall comply with all requirements of this consumer safety specification before and after testing as specified in Section 7 of this consumer safety specification.

4.2 *Wood Parts*—Prior to testing, any exposed wood parts shall be smooth and free from splinters.

4.3 *Regulations and Standards*—Beds shall conform to all regulations and documents referenced in Section 2 before and after all testing.

4.4 *Scissoring, Shearing, and Pinching*—When in the manufacturer's recommended use position, the bed shall be designed and constructed to prevent injury from any scissoring, shearing, or pinching when members or components rotate about a common axis or fastening point, slide, pivot, or fold or otherwise move relative to one another. Scissoring, shearing, or pinching occurs when the edges of rigid material admit a probe that is greater than 0.210 in. (5.30 mm) diameter and less than 0.375 in. (9.50 mm) diameter at any accessible point throughout the range of motion of such parts that may cause injury.

4.5 *Methods of Protection*—Components such as caps, sleeves, or plugs used for protection from sharp edges, points, or entrapment of fingers or toes shall not be removed when tested in accordance with 7.6.

4.6 *Openings*—Any shaped holes, slots or cracks that exist in the bed in its manufacturer's recommended use position, and that are accessible to the toes or fingers of the occupant, through or recessed, or both, into the surface of any rigid material that admit a 0.210 in. (5.30 mm) diameter rod, shall also admit a 0.375 in. (9.50 mm) diameter rod. Openings that have a minimum dimension between 0.210 and 0.375 in. (5.30 and 9.50 mm) shall be permissible, provided that the depth is no greater than the minimum dimension of the opening.

5. Performance Requirement

5.1 *Mattress Retention:*

5.1.1 The mattress support system, end structures, and side containment shall control the horizontal position of the mattress and prevent it from being moved horizontally creating a

horizontal opening that allows complete passage of the wedge block when tested in accordance with 7.1.

5.1.2 The top of the mattress shall not deflect below the bottom of the mattress support when tested in accordance with 7.1.6.

5.2 *Mattress Support System*—The mattress support system shall not disengage or create a hazardous condition as described in Section 4 of this consumer safety specification when tested in accordance with 7.2.

5.3 *Mattress Support System Attachment to End Structures:*

5.3.1 The mattress support system attachment to the end structures shall not disengage or create a hazardous condition as described in Section 4 of this consumer safety specification when tested in accordance with 7.3.

5.3.2 In products that contain both side rails and a separate mattress support system, the tests described in both 7.3.2 and 7.3.3 shall apply to both.

5.4 *Guardrails*—For products with guardrails, there shall be no opening in the guardrail structure below the lowest surface of the uppermost member of the guardrail and above the mattress support structure that would permit passage of the wedge block shown in Fig. 1 when tested in accordance with 7.4.2.

5.5 *End Structures*—There shall be no opening above the mattress support system in the end structures that will permit passage of the wedge block shown in Fig. 1 when tested in accordance with 7.5.1 unless it also permits passage of the head probe (see Fig. 2) when tested in accordance with 7.5.2.

6. Calibration and Standardization

6.1 Conduct all testing on a concrete floor that may be covered with a 1/8 in. (3 mm) thick vinyl flooring cover, unless test instructs differently.

6.2 Assemble the bed completely in accordance with the manufacturer's instructions, unless otherwise noted.

6.3 No testing shall be conducted within 48 h of manufacturing.

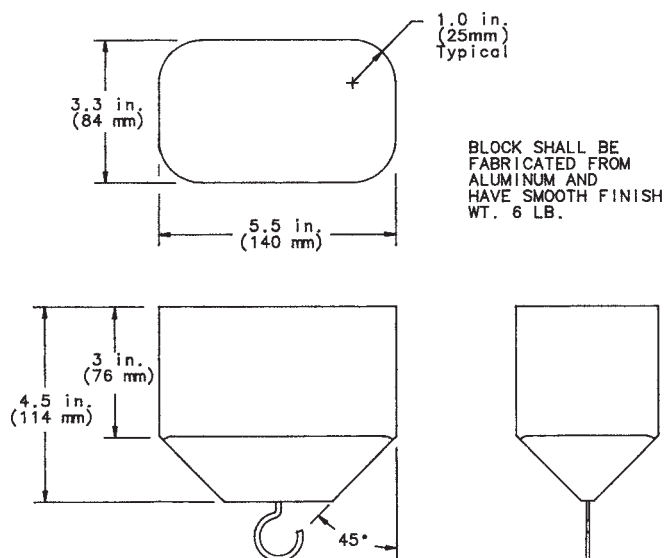
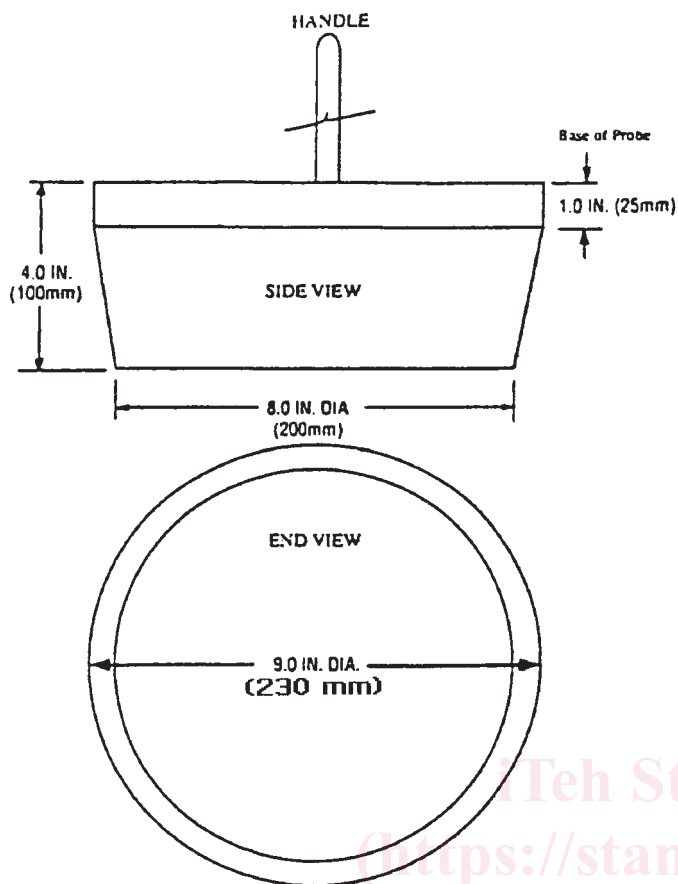

FIG. 1 Wedge Block



NOTE—Material: Any rigid material.
FIG. 2 Head Probe

6.4 The bed to be tested shall be in a room with ambient temperature of $73 \pm 9^\circ\text{F}$ ($23 \pm 5^\circ\text{C}$) for at least 1 h prior to testing. Then conduct testing within this temperature range.

6.5 All testing required by this consumer safety specification is to be conducted on the same unit.

7. Test Methods

7.1 Mattress Retention:

7.1.1 *Test Mattress*—A $4 \pm \frac{1}{8}$ in. (100 ± 3 mm) thick by $51 \frac{5}{8} \pm \frac{1}{8}$ in. (1310 ± 3 mm) long by $27 \frac{1}{4} \pm \frac{1}{8}$ in. (690 ± 3 mm) wide, open cell, polyurethane foam pad having a density of 1 lb/ft^3 (16 kg/m^3) covered with a 5 to 15 gage vinyl material, 0.005 to 0.015 in. (0.13 to 0.38 mm) thick shall be used to represent a mattress during the performance of the following tests:

7.1.1.1 *Rationale*—This is the mattress of the least thickness, length, width, and rigidity found on the open market for full-size cribs.

7.1.2 Secure the bed so that it cannot move during the performance of the following tests.

7.1.3 Using a 3-in. (76-mm) diameter flat, rigid disk, gradually apply a 5 lbf (22 N) horizontally within a period of 5 s to the edge of the mattress at the vertical midpoint and maintain for 30 s in a location that produces the largest gap in the horizontal plane between the end support structures, side rails, or guardrails and the edge of the mattress.

7.1.3.1 *Rationale*—The purpose of this test is to cause maximum displacement of the mattress to the side. This is to open the widest possible gap between the mattress and its support structure to test for potentially hazardous gaps. The test is to be conducted in as many places as is required to discover the place or places that will open the largest possible gap.

7.1.4 After the test described in 7.1.3 has been performed, any gap in the horizontal plane that permits the passage of a vertically oriented 0.19 in. (5 mm) diameter probe with a length of 6 in. (150 mm), minimum, and that has a fully rounded end to pass through without touching either the mattress or the support structure shall be tested in accordance with 7.1.5.

7.1.4.1 *Rationale*—The dimension of 0.19 in. (5 mm) is used as a rounded, two place decimal equivalent to $\frac{3}{16}$ in. (5 mm).

7.1.5 Insert the tapered end of the wedge block, shown in Fig. 1, into any gap identified in 7.1.4 in the most adverse orientation, and gradually apply a 39-lb (17.7 kg) dead weight to the wedge block within a period of 5 s; maintain the load for a period of 30 s.

7.1.6 Place a 3 in. (76 mm) by 7.2 in. (183 mm) sheet of $\frac{3}{4}$ in. (19 mm) thick plywood in the most adverse position on the top of the mattress. Do not allow any portion of the plywood to extend over the edge of the mattress. While keeping the plywood horizontal, gradually apply a 50 lbf (220 N) force normal to the plywood within a period a 5 s. Maintain the load for 30 s.

7.2 Mattress Support System:

7.2.1 Conduct the following test without a mattress in place unless specified otherwise.

7.2.1.1 *Rationale*—The following tests are conducted without a mattress in place. The construction of the mattress would affect the test results, and in any case would help spread the stresses of the tests and thereby reduce their severity. Any reduction of stress within the unit that the mattress provides will help to enhance the actual performance of the product in the field.

7.2.2 Center a sheet of $\frac{3}{4}$ in. (19 mm) thick plywood 19 in. (480 mm) wide by 37 in. (940 mm) long on the mattress support system. Place a mass of 300 lb (136 kg) on the plywood sheet. The mass is to be distributed equally, applied gradually within a period of 5 s and shall remain in place for 5 min. Remove the mass.

7.2.2.1 *Rationale*—This mass represents the weight of the parent and child on the bed together.

7.2.3 Center a sheet of $\frac{3}{4}$ in. (19 mm) thick plywood 19 in. (480 mm) square on the longitudinal centerline of the mattress support system with one edge in line with the inside vertical plane of one end structure of the bed. Place a mass of 225 lb (102 kg) on the plywood sheet. The mass is to be distributed equally, applied gradually within a period of 5 s and shall remain in place for 5 min. Remove the mass. Repeat this test at the opposite end structure.

7.2.3.1 *Rationale*—This weight represents that of an adult who may sit in the center of the bed at either end in the center of the mattress.