



SLOVENSKI STANDARD
SIST ISO 6768:1999
01-marec-1999

Ni bUb]nfU_!`8c`c Yj Ub^a UgbY_cbWbhfUW^YXi y]_cj Y[UX]c_g]XU!`Df]U c^bU
; f]Ygg!GUlma Ubcj Ua YrcXU

Ambient air -- Determination of mass concentration of nitrogen dioxide -- Modified Griess
-Saltzman method

iTeh STANDARD PREVIEW

Air ambient -- Détermination de la concentration en masse de dioxyde d'azote --
Méthode de Griess-Saltzman modifiée

[SIST ISO 6768:1999](https://standards.iteh.ai/catalog/standards/sist/a93dae3-2cd2-4d2f-92a7-75a0c6a414c5/sist-iso-6768-1999)

Ta slovenski standard je istoveten z: [ISO 6768:1998](https://standards.iteh.ai/catalog/standards/sist/a93dae3-2cd2-4d2f-92a7-75a0c6a414c5/sist-iso-6768-1999)

ICS:

13.040.20 Kakovost okoljskega zraka Ambient atmospheres

SIST ISO 6768:1999

en

iTeh STANDARD PREVIEW
(standards.iteh.ai)

SIST ISO 6768:1999

<https://standards.iteh.ai/catalog/standards/sist/a93daef3-2cd2-4d2f-92a7-73a0cba414c5/sist-iso-6768-1999>

INTERNATIONAL STANDARD

**ISO
6768**

Second edition
1998-08-01

Ambient air — Determination of mass concentration of nitrogen dioxide — Modified Griess-Saltzman method

*Air ambient — Détermination de la concentration en masse de dioxyde
d'azote — Méthode de Griess-Saltzman modifiée*

iTeh STANDARD PREVIEW
(standards.iteh.ai)

[SIST ISO 6768:1999](https://standards.iteh.ai/catalog/standards/sist/a93daef3-2cd2-4d2f-92a7-73a0cba414c5/sist-iso-6768-1999)

<https://standards.iteh.ai/catalog/standards/sist/a93daef3-2cd2-4d2f-92a7-73a0cba414c5/sist-iso-6768-1999>



Reference number
ISO 6768:1998(E)

ISO 6768:1998(E)**Foreword**

ISO (the International Organization for Standardization) is a worldwide federation of national standards bodies (ISO member bodies). The work of preparing International Standards is normally carried out through ISO technical committees. Each member body interested in a subject for which a technical committee has been established has the right to be represented on that committee. International organizations, governmental and non-governmental, in liaison with ISO, also take part in the work. ISO collaborates closely with the International Electrotechnical Commission (IEC) on all matters of electrotechnical standardization.

Draft International Standards adopted by the technical committees are circulated to the member bodies for voting. Publication as an International Standard requires approval by at least 75 % of the member bodies casting a vote.

International Standard ISO 6768 was prepared by Technical Committee ISO/TC 146, *Air quality*, Subcommittee SC 3, *Ambient atmospheres*.

This second edition cancels and replaces the first edition (ISO 6768:1985), which has been technically revised.

Annex A of this International Standard is for information only.

iTeh STANDARD PREVIEW **(standards.iteh.ai)**

[SIST ISO 6768:1999](https://standards.iteh.ai/catalog/standards/sist/a93daef3-2cd2-4d2f-92a7-73a0cba414c5/sist-iso-6768-1999)

<https://standards.iteh.ai/catalog/standards/sist/a93daef3-2cd2-4d2f-92a7-73a0cba414c5/sist-iso-6768-1999>

© ISO 1998

All rights reserved. Unless otherwise specified, no part of this publication may be reproduced or utilized in any form or by any means, electronic or mechanical, including photocopying and microfilm, without permission in writing from the publisher.

International Organization for Standardization
Case postale 56 • CH-1211 Genève 20 • Switzerland
Internet iso@iso.ch

Printed in Switzerland

Ambient air — Determination of mass concentration of nitrogen dioxide — Modified Griess-Saltzman method

1 Scope

This International Standard specifies a modified Griess-Saltzman method for the determination of the mass concentration of nitrogen dioxide present in ambient air.

The method is applicable to the determination of the mass concentration of nitrogen dioxide present in ambient and confined air within the range 0,003 mg/m³ to 2 mg/m³ and for sampling times between 10 min and 2 h.

Substances present in the air mass under investigation, and thus in the air sample, and known to have an effect on the instrument reading, are given in 7.4. Information on the performance characteristics is given in 8.2.

The method is not suitable for personal breathing-zone sampling.

The Griess-Saltzman method is suitable for the analytical check of calibration gas mixtures which are used to calibrate chemiluminescence analysers (see ISO 7996).

ITeH STANDARD PREVIEW
(standards.iteh.ai)

2 Normative reference

SIST ISO 6768:1999

<https://standards.iteh.ai/catalog/standards/sist/a93dae3-2cd2-4d2f-92a7-7e00a47c3384/iso-6768-1999>

The following standard contains provisions which, through reference to this text, constitute provisions of this International Standard. At the time of publication, the edition indicated was valid. All standards are subject to revision, and parties to agreements based on this International Standard are encouraged to investigate the possibility of applying the most recent edition of the standard indicated below. Members of IEC and ISO maintain registers of currently valid International Standards.

ISO 6349:1979, *Gas analysis — Preparation of calibration gas mixtures — Permeation method*.

3 Principle

The nitrogen dioxide present in an air sample is absorbed by passage through an azo-dye-forming reagent within a specified period, resulting in the formation of a pink colour within 15 min.

The absorbance of the sample solution is then determined at a wavelength between 540 nm and 550 nm using an appropriate spectrophotometer. The corresponding mass concentration of nitrogen dioxide is determined from a calibration graph of absorbance vs. concentration prepared using sodium nitrite solutions of known concentrations.

4 Reagents

During the analysis, use only reagents of recognized analytical grade and only nitrite-free water (4.1).

4.1 Nitrite-free water.

If the water used to prepare the absorption and calibration solutions results in a pink coloration due to the presence of nitrite in the water, prepare nitrite-free water as follows. Add one crystal each of potassium permanganate (KMnO_4) and barium hydroxide [$\text{Ba}(\text{OH})_2$] to the water and redistill using an all-glass still.

4.2 *N*-(1-naphthyl)ethylenediamine dihydrochloride, 0,5 g/l stock solution.

Dissolve 0,5 g of *N*-(1-naphthyl)ethylenediamine dihydrochloride [$\text{C}_{10}\text{H}_7\text{NH}(\text{CH}_2)_2\text{NH}_2 \cdot 2\text{HCl}$] in 1000 ml of nitrite-free water (4.1).

Store in a stoppered brown glass bottle at a temperature below 5 °C. The solution is stable for several months.

NOTE It is also possible to store small weighed amounts of the solid reagent.

4.3 Absorption solution.

Dissolve 5,0 g of sulfanilic acid ($\text{C}_6\text{H}_4\text{SO}_3\text{H}_2\text{NH}_2$) in approx. 600 ml of nitrite-free water (4.1) and 50 ml of acetic acid by heating, if necessary, in a 1000 ml one-mark volumetric flask. Cool the solution to room temperature, add 100 ml of *N*-(1-naphthyl)ethylenediamine dihydrochloride solution (4.2), mix and make up to the mark with nitrite-free water (4.1)

Store in a well-stoppered brown glass bottle at a temperature below 5°C. The solution is stable for 2 weeks.

4.4 Gas mixtures.

Prepare gas mixtures, which are used to test the absorption efficiency (7.1.1), following the permeation technique specified in ISO 6349 or by an equivalent method.

4.5 Reagents for preparation of the calibration graph

4.5.1 Nitrite solution, $\rho_{\text{NO}_2} = 250 \text{ mg/l}$.

Dissolve 375 mg of sodium nitrite (NaNO_2) in nitrite-free water (4.1) in a 1000 ml one-mark volumetric flask. Make up to the mark with nitrite-free water and mix well.

Store in a well-stoppered bottle. The solution is stable for at least 3 months.

1 ml of this solution contains 250 μg of NO_2^- .

4.5.2 Nitrite solution, $\rho_{\text{NO}_2} = 2,5 \text{ mg/l}$.

Transfer 10,0 ml of nitrite solution (4.5.1) to a 1000 ml one-mark volumetric flask. Make up to the mark with nitrite-free water (4.1) and mix well.

Prepare this solution immediately before use.

1 ml of this solution contains 2,5 μg of NO_2^- .

5 Apparatus

5.1 Ordinary laboratory apparatus and sampling equipment, as specified in 5.1.1 to 5.1.7.

5.1.1 Sampling probe.

Borosilicate glass, stainless steel or polytetrafluoroethylene tube whose internal diameter is approximately 6 mm and which is as short as possible, but in any case not longer than 2 m, provided with a downward-facing air intake.

If the use of such short sampling probes is not possible, an auxiliary sampling pipe consisting of a sampling probe of internal diameter about 50 mm, provided with a joint for attachment to the sampling train, and a pump drawing air at a volume flowrate of about 2 m³/h shall be used [see figure 1 c)].

5.1.2 Cotton wool filter.

Borosilicate glass tube, of internal diameter at least 15 mm and length approximately 80 mm, loosely packed with bleached, not optically brightened, and non-finished cotton wool. It shall be a component of the sampling train only if it is considered necessary to remove ozone from the air before it enters the fritted bubbler (see also 7.4).

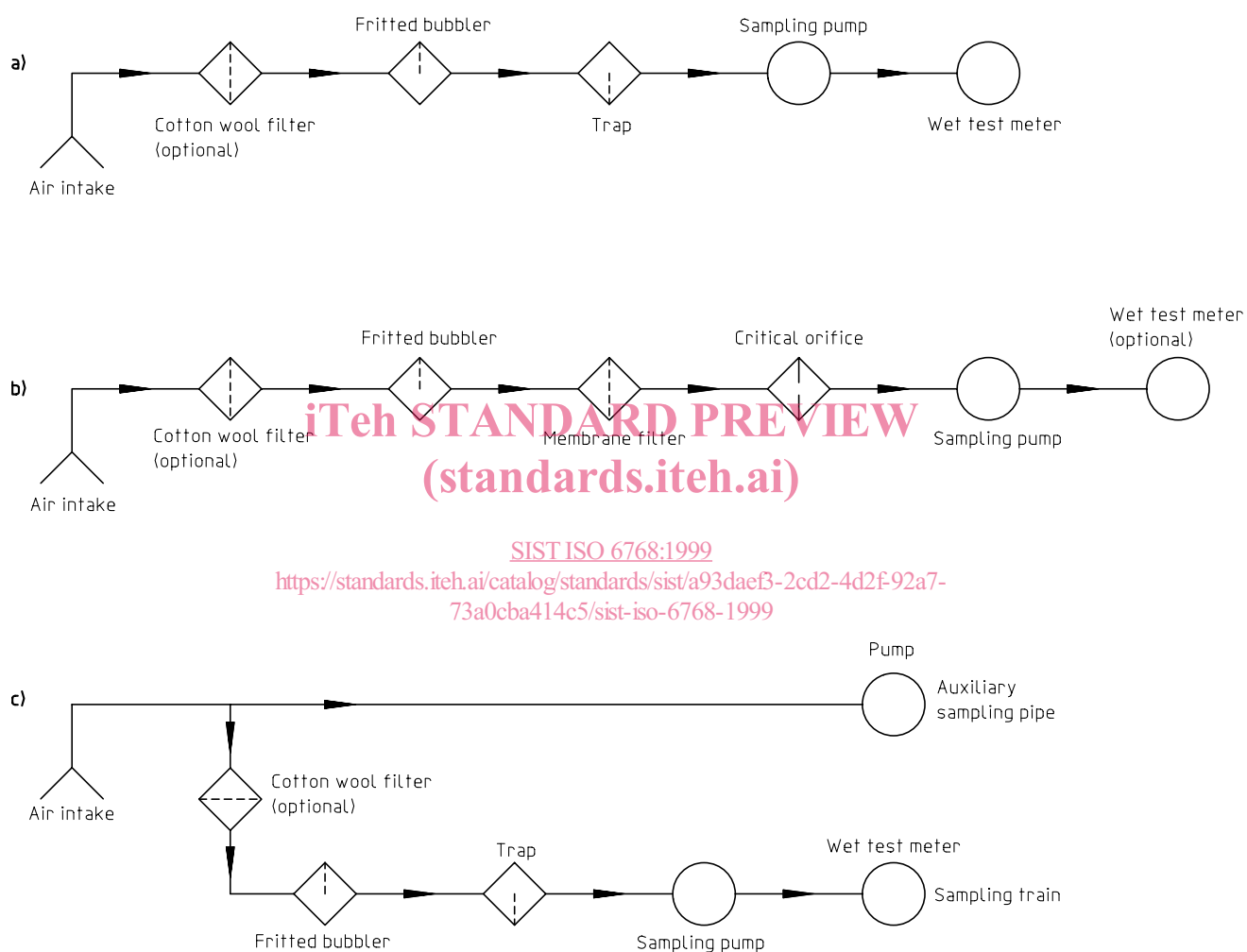

Figure 1 — Examples of sampling trains capable of the determination of the mass concentration of nitrogen dioxide in ambient air

5.1.3 Fritted bubbler.

Borosilicate all-glass bubblers equipped with a frit whose porosity shall be fine enough to enable an absorption efficiency of at least 0,95 to be attained without providing too great a pressure drop in use. Frits having pore diameters between 40 µm and 60 µm are suitable. Four examples of fritted bubblers (types A to D) that have been found to be suitable are shown in figure 2.

The absorption efficiency of each individual fritted bubbler shall be tested at least once a year using calibration gas mixtures prepared following the permeation technique specified in ISO 6349 or by an equivalent method.

Coloured frits shall be cleaned with a mixture of a potassium dichromate solution and concentrated sulfuric acid or other appropriate cleaning agents. When a dichromate-sulfuric acid mixture is used, care shall be taken that the frits are thoroughly rinsed with nitrite-free water (4.1).

WARNING — Avoid physical contact with dichromate and reagents containing dichromate, in particular with a dichromate-sulfuric acid mixture.

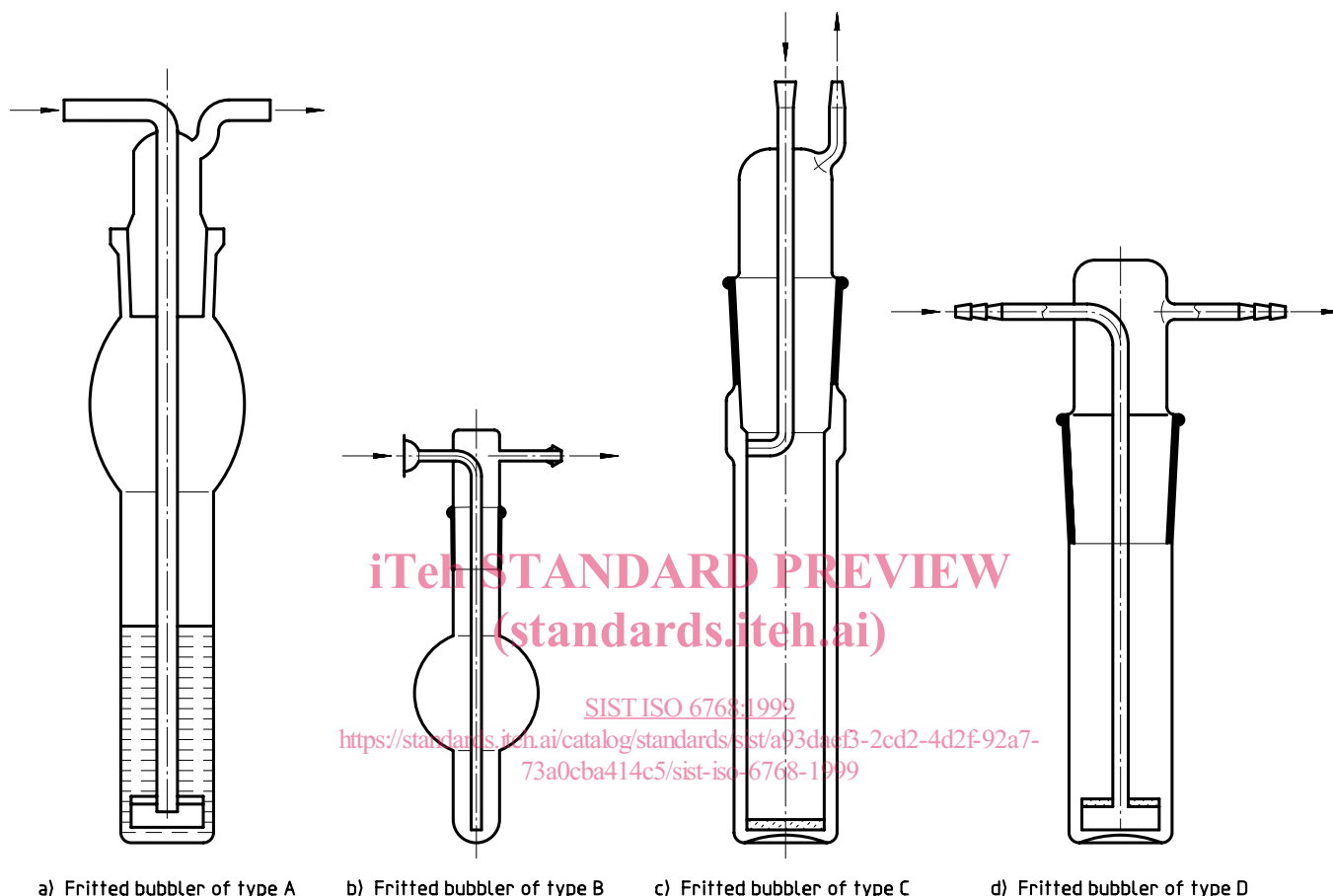

Figure 2 — Examples of absorbers suitable for sampling nitrogen dioxide

(The ends of the glass tubes of each of these absorbers can be designed as spherical ground joints, conical ground joints or olives.)

5.1.4 Trap.

Conical flask of capacity 100 ml, filled with glass-wool.

5.1.5 Membrane filter.

5.1.6 Sampling pump and control system, capable of drawing air at a volume flow rate of about 0,4 l/min to 0,6 l/min during the sampling period.

5.1.7 Air metering device.

Use either a wet test meter, a calibrated all-glass variable-area flowmeter, a calibrated critical orifice or a calibrated mass flowmeter. In all cases, the air volume flowrate should be known to within $\pm 5\%$.

A wet test meter or a soap bubble meter is convenient for testing the calibration of the variable-area flowmeter, the critical orifice or the mass flowmeter.

5.2 Spectrophotometer, capable of determining absorbance at a wavelength of between 540 nm and 550 nm, and capable of taking optical cells for spectrophotometric measurements of liquids as specified in 5.3.

5.3 Optical cells, plane, matched pairs, having an optical pathlength of 10 mm to 50 mm.

5.4 One-mark pipettes, of capacities 5 ml; 10 ml; 15 ml; 20 ml; 25 ml; 50 ml.

6 Sampling

Assemble a sampling train in accordance with the examples shown in figure 1 and any special requirements for the air mass under investigation. Use ground glass joints upstream from the fritted bubbler or butt-to-butt glass with polyvinylchloride or polytetrafluoroethylene connections.

Transfer, by means of a pipette (5.4), a suitable volume of absorption solution (4.3) into the dry fritted bubbler (5.1.3), namely 25 ml for fritted bubblers of type A, 20 ml for fritted bubblers of type B, 50 ml for fritted bubblers of type C and 10 ml for fritted bubblers of type D. Connect the fritted bubbler to the sampling train.

Record the reading on the wet test meter (5.1.7) and the time, and start the sampling pump (5.1.6). Adjust the air-volume flow regulator to give an air-volume flowrate of about 0,4 l/min to 0,6 l/min.

The sampling period shall be 10 min to 2 h as required. Protect the absorption solution from light during sampling.

At the end of the sampling period, switch off the sampling pump, note the reading on the wet test meter and the time. Remove the fritted bubbler from the sampling train. Mix the bulk of the sample solution outside the frit with the small quantity of the sample solution inside the frit by sucking a sufficient portion through the frit and then releasing. Repeat several times.

Stopper the fritted bubbler carefully and protect the sample solution from light. Allow the sample solution to stand for 15 min.

Due to the limited time stability of the sample solution, the interval of time between the end of sampling and the beginning of measurements to be carried out with the sample solution shall not exceed 20 h.

NOTE Generally, the influence of evaporation can be neglected for short sampling periods. However, with an extended sampling period, a small volume of absorption solution and dry air conditions, the influence of evaporation should be taken into account.

7 Procedure

7.1 Test of fritted bubblers

7.1.1 Test of absorption efficiency

In accordance with the examples shown in figure 1, assemble a sampling train where two fritted bubblers of the same type are connected in series, each of them containing the appropriate volume of absorption solution, as specified in clause 6.

Introduce the inlet of the sampling train into the outlet of a permeation device (or use an equivalent method) capable of producing gas mixtures (see 4.4) at a volume flowrate higher than that expected at the intake area of the sampling train. Prepare a gas mixture having a mass concentration of nitrogen dioxide of about 1 mg/m³. Avoid mass concentrations of nitrogen dioxide higher than 2 mg/m³.

Choose a sampling period resulting in the absorption of a mass of nitrogen dioxide of about 0,5 µg per 1 ml of the absorption solution exposed in the first fritted bubbler, and carry out sampling as specified in clause 6.

Calculate the absorption efficiency by dividing the absorbance of the sample solution in the first fritted bubbler by the sum of the absorbances of the sample solution in the first and the second fritted bubbler.