



Designation: D 6195 – 97

Standard Test Methods for Loop Tack¹

This standard is issued under the fixed designation D 6195; the number immediately following the designation indicates the year of original adoption or, in the case of revision, the year of last revision. A number in parentheses indicates the year of last reappraisal. A superscript epsilon (ϵ) indicates an editorial change since the last revision or reappraisal.

1. Scope

1.1 These test methods cover the determination of properties of a pressure-sensitive adhesive. This test method is applicable to those adhesives that form a bond of measurable strength rapidly upon contact with another surface. Tack force may be measured as the force required to separate the adhesive from the adherend at the interface shortly after they have been brought into contact under a load equal only to the weight of the pressure-sensitive article (for example, tape, label, sticker, etc.) on a 1 in.² contact area.

1.2 The following test methods are included:

1.2.1 *Test Method A* (using Tensile Tester), and

1.2.2 *Test Method B* (using Loop Tack Tester).

1.3 The values stated in inch-pound units are to be regarded as the standard. The values given in parentheses are for information purposes only.

1.4 *This standard does not purport to address all of the safety concerns, if any, associated with its use. It is the responsibility of the user of this standard to establish appropriate safety and health practices and determine the applicability of regulatory limitations prior to use.*

2. Referenced Documents

2.1 ASTM Standards:

A 666 Specification for Annealed or Cold-Worked Austenitic Stainless Steel, Sheet, Strip, Plate, and Flat Bar²

D 907 Terminology of Adhesives³

D 2651 Guide for Preparation of Metal Surfaces for Adhesive Bonding³

E 171 Specification for Standard Atmospheres for Conditioning and Testing Flexible Barrier Materials⁴

E 177 Practice for Use of the Terms Precision and Bias in ASTM Test Methods⁵

E 691 Practice for Conducting an Interlaboratory Study to Determine the Precision of a Test Method⁵

2.2 *European Association for the Pre-Adhesed Labeling Industry (FINAT) Standard:*⁶

FTM 9 “Quick-Stick” Tack Measurement

2.3 *Tag and Label Manufacturers Institute, Inc. (TLMI) Standard:*⁷

L-IB1 TLMI Loop Tack Test

L-IB2 Tensile Tester Loop Tack Test

3. Terminology

3.1 Definitions:

3.1.1 Many of the terms found in this test method are defined in Terminology D 907.

4. Summary of Test Method

4.1 These test methods involve allowing a loop of pressure-sensitive adhesive with its backing to be brought into controlled contact with a 1 in.² (25 by 25 mm) surface of stainless steel, with the only force applied being the weight of the pressure-sensitive article itself. The pressure-sensitive article is then removed from the substrate, with the force to remove the pressure-sensitive article from the adherend measured by a recording instrument.

4.2 *Test Method A* (using a Tensile Tester) applies when a Tensile Tester is used to measure loop tack and involves the use of a loop prepared from an 7 in. (175 mm) specimen strip.

4.3 *Test Method B* (using a Loop Tack Tester) applies when a Loop Tack Tester is used to measure loop tack and involves the use of a loop prepared from a 5 in. (125 mm) specimen strip.

5. Significance and Use

5.1 These test methods provide a quantitative measure of the pressure-sensitive tack property of an adhesive.

5.2 These test methods are designed to measure the tack property of the adhesive mass. The tack of a given adhesive varies depending on the backing (generally, stiffer backings lead to higher values).

5.3 These test methods are suitable for quality control and research purposes.

¹ This test method is under the jurisdiction of ASTM Committee D-14 on Adhesives and is the direct responsibility of Subcommittee D14.50 on Hot Melt and Pressure Sensitive Adhesives.

Current edition approved November 10, 1997. Published May 1998.

² *Annual Book of ASTM Standards*, Vol 01.03.

³ *Annual Book of ASTM Standards*, Vol 15.06.

⁴ *Annual Book of ASTM Standards*, Vol 15.09.

⁵ *Annual Book of ASTM Standards*, Vol 14.02.

⁶ Available from FINAT, Laan Copes Van Cattenburch 79, 2585 EW, The Hague, Holland.

⁷ Available from TLMI, 40 Shuman Blvd., Ste. 295, Naperville, IL 60563.

5.4 *Test Method A* (using Tensile Tester) makes use of a specimen strip 7 in. (175 mm) in length. Both the FINAT FTM 9 “Quick Stick” Tack Measurement Test and the TLMI L-IB2 Tensile Tester Loop Tack Test also use a specimen strip of that length.

5.5 *Test Method B* (using Loop Tack Tester) makes use of a specimen strip five in. (125 mm) in length. That is the only length specimen strip that fits properly in the loop tack tester.

5.6 If the adhesive is not already otherwise coated, these test methods incorporate the use of a clear 2 mil (0.05 mm) polyester (PET) film backing for specimen preparation. Use of other backing materials changes performance of the specimen to be tested.

TEST METHOD A (Using a Tensile Tester)

6. Apparatus

6.1 *Tensile Tester*—A constant rate of extension type.

6.2 *Test Fixture* (Fig. 1 or Fig. 2⁸)—To be mounted into the jaws of the tensile tester. A panel held by the test fixture allows for a 1 in.² (25 by 25 mm) contact area of the pressure-sensitive article. Alternately, the test fixture may include a raised area that allows a 1 in.² (25 by 25 mm) contact area of the pressure-sensitive article.

6.2.1 The panel or the raised area of the test fixture is stainless steel as specified in Specification A 666.

6.3 *Apparatus for Cutting:*

6.3.1 *Die Cutter*—A 1 by 7 in. (25 by 175 mm) rectangular mallet-type die cutter with mallet for sample preparation.

6.3.2 If a fixed dimension die is unavailable, substitute a 1-in. (25-mm) steel bar with a double razor knife or other apparatus suitable for cutting the specimen into the specified dimensions to prepare the 1 in. (25 mm) wide specimen strips.

6.4 *Absorbent Lint-Free Cleaning Material*—Materials produced from entirely virgin raw materials and containing less than 0.25 % by weight of solvent-leachable materials.

6.5 *Masking Tape*—1 in. (25 mm) wide.

6.6 2 mil (0.05 mm) PET Film—To be used as a support medium in evaluating unsupported adhesives such as transfer tapes, laminating adhesives, or other free-film adhesives.

6.7 *Reagents*—Appropriate reagents include acetone, diacetone alcohol, n-heptane and toluene, reagent or analytical grade, or an ethanol cleaner for water-based adhesives.

⁸ Available from Chem Instruments, 510 Commercial Drive, Fairfield, OH 45014-7593.

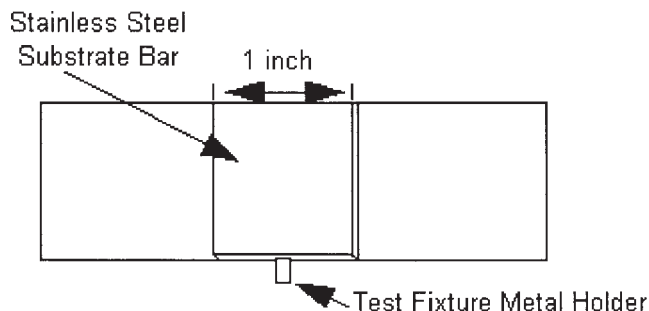
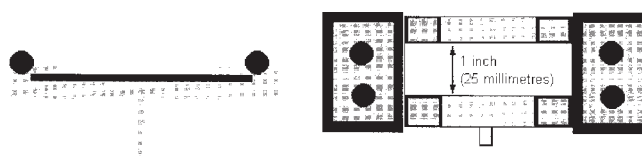

FIG. 1 Loop Tack Test Fixture 1



A. Side View B. Top View

FIG. 2 Loop Tack Test Fixture 2

7. Sample Preparation

7.1 Cut sample into 1 by 7 in. (25 by 175 mm) specimen strips in the machine direction (when known) of the pressure-sensitive article. Use of strips of other lengths may change results. Cut at least three specimen strips for each adhesive to be tested.

NOTE 1—If transfer or unsupported adhesives are to be tested, these are to be laminated to 2 mil (0.05 mm) PET film, used as an adhesive support, prior to cutting the samples into the 1 by 7 in. (25 by 175 mm) specimen strips.

7.2 Condition specimens to be tested for at least 24 h in a testing room at 73.4 ± 3.6°F (23 ± 2°C) and a relative humidity of 50 ± 5 %, in accordance with Specification E 171, prior to conducting the test.

8. Conditioning

8.1 *Testing Room*—Test in a standard laboratory atmosphere, at 73.4 ± 3.6°F (23 ± 2°C) and a relative humidity of 50 ± 5 %, in accordance with Specification E 171.

9. Procedure

9.1 Ensure that the tensile tester is calibrated according to instructions supplied by the manufacturer.

9.2 Set the instrument crosshead speed at 12 in. (300 mm)/min.

9.3 Place the test fixture in the lower grip of the tensile tester. It is important that the test fixture be level and straight in the lower grip. See Fig. 1, Fig. 2 and Fig. 3.

9.4 Set gaps for the crosshead using the minimum and maximum gap setting on the extension cycle. Set gaps 1 ± 0.05 in. (25 ± 1 mm) (critical) and 4 ± 0.1 in. (100 ± 3 mm) (optional) from the bottom of the upper grips to the face of the stainless steel portion of the test fixture when the test fixture is

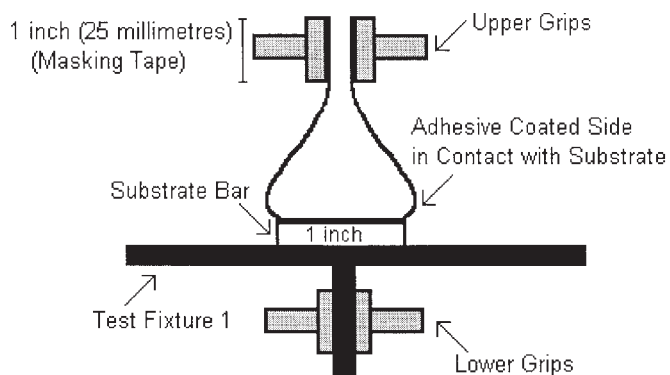

FIG. 3 Loop Tack Sample During Test