

---

# International Standard



# 6786

---

INTERNATIONAL ORGANIZATION FOR STANDARDIZATION • МЕЖДУНАРОДНАЯ ОРГАНИЗАЦИЯ ПО СТАНДАРТИЗАЦИИ • ORGANISATION INTERNATIONALE DE NORMALISATION

---

## Road vehicles — Air braking systems — Identification of connections on units

*Véhicules routiers — Dispositifs de freinage à air comprimé — Repérage des orifices sur les appareils*

First edition — 1980-06-15

ISO 6786:1980  
https://standards.iteh.ai/catalog/standards/sist/7008150-d116-4abe-9ba5-a2e4ec5f787e/iso-6786-1980  
iteh STANDARD PREVIEW  
(standards.iteh.ai)

## Foreword

ISO (the International Organization for Standardization) is a worldwide federation of national standards institutes (ISO member bodies). The work of developing International Standards is carried out through ISO technical committees. Every member body interested in a subject for which a technical committee has been set up has the right to be represented on that committee. International organizations, governmental and non-governmental, in liaison with ISO, also take part in the work.

Draft International Standards adopted by the technical committees are circulated to the member bodies for approval before their acceptance as International Standards by the ISO Council.

International Standard ISO 6786 was developed by Technical Committee ISO/TC 22, *Road vehicles*, and was circulated to the member bodies in July 1979.

**iTeh STANDARD PREVIEW**  
(standards.iteh.ai)

It has been approved by the member bodies of the following countries :

Australia	Italy	South Africa, Rep. of
Austria	Japan	Spain
Belgium	Korea, Dem. P. Rep. of	Sweden
Chile	Korea, Rep. of	Switzerland
China	Netherlands	United Kingdom
Czechoslovakia	New Zealand	USA
France	Poland	USSR
Germany, F. R.	Romania	

No member body expressed disapproval of the document.

# Road vehicles — Air braking systems — Identification of connections on units

## 1 Scope

This International Standard specifies an identification system for pipe connections on units of air braking systems. The digits designated shall be placed close to the ports on the units.

## 2 Field of application

This International Standard applies to motor vehicles and their trailers and may also be used for schematic diagrams of braking systems.

## 3 Identification

**3.1** The identification code consists of a one or two digit number as follows.

**3.1.1** First digit :

- 0 Suction connection
- 1 Energy inlet
- 2 Energy supply (not to atmosphere, see digit 3)
- 3 Exhaust
- 4 Pilot connection (entry into unit)
- 5 Spare
- 6 Spare
- 7 Anti-freeze liquid connection
- 8 Lubricating oil connection (for compressor)
- 9 Cooling liquid connection (for compressor)

**3.1.2** Second digit :

A second digit may be added, when several similar connections are available, for example with split systems. The function represented by this second digit is left to the discretion of the vehicle manufacturer, but should start at 1 and continue uninterrupted, for example 21, 22, 23, etc. Exceptions are permitted when applying the "building block" principle.

**3.2** The following codes are not allowed for free choice :

- 71 Anti-freeze inlet
- 72 Anti-freeze outlet

- 81 Lubricating oil inlet
- 82 Lubricating oil outlet
- 91 Cooling liquid inlet
- 92 Cooling liquid outlet

If there are a number of similar connections belonging to one unit and intended to fulfil the same function, they shall have the same designation.

A connection which can fulfil, in any one application, more than one function shall be identified by two (first) digits. These shall be separated by a dash (see example in clause 4).

A connection which can fulfil more than one function in different applications shall be identified in accordance with agreement between the manufacturer and customer (for example multiway valves).

## 4 Example

Unit with filling and switching connections

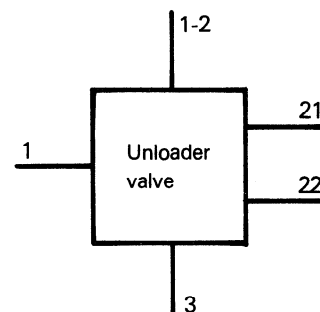

In this example the references signify :

- 1 Energy inlet from the compressor
- 1-2 Energy inlet using a valve for filling the air braking system, and energy supply by use of a valve as used for blowing up tyres
- 3 Connection to atmosphere (venting)
- 21 Energy supply to the energy accumulator (air reservoir)
- 22 Energy supply (switching connection).

**iTeh STANDARD PREVIEW**  
**(standards.iteh.ai)**

This page intentionally left blank

[ISO 6786:1980](#)

<https://standards.iteh.ai/catalog/standards/sist/70088c50-d116-4abe-9ba5-a2e4ee5f787e/iso-6786-1980>