

---

# International Standard



# 6793

---

INTERNATIONAL ORGANIZATION FOR STANDARDIZATION • МЕЖДУНАРОДНАЯ ОРГАНИЗАЦИЯ ПО СТАНДАРТИЗАЦИИ • ORGANISATION INTERNATIONALE DE NORMALISATION

---

## But-2-ene-1,4-diol for industrial use — Determination of iodine value

*Butène-2-diol-1,4 à usage industriel — Détermination de l'indice d'iode*

First edition — 1981-11-01

**ITeH STANDARD PREVIEW**  
**(standards.iteh.ai)**

[ISO 6793:1981](#)

<https://standards.iteh.ai/catalog/standards/sist/4c2b874a-2507-4618-9b5b-9c7d622afbe0/iso-6793-1981>

---

UDC 661.716.2 : 543.242.3

Ref. No. ISO 6793-1981 (E)

Descriptors : industrial products, chemical compounds, determination, iodine number, iodometric analysis, titration.

## Foreword

ISO (the International Organization for Standardization) is a worldwide federation of national standards institutes (ISO member bodies). The work of developing International Standards is carried out through ISO technical committees. Every member body interested in a subject for which a technical committee has been set up has the right to be represented on that committee. International organizations, governmental and non-governmental, in liaison with ISO, also take part in the work.

Draft International Standards adopted by the technical committees are circulated to the member bodies for approval before their acceptance as International Standards by the ISO Council.

International Standard ISO 6793 was developed by Technical Committee ISO/TC 47, *Chemistry*, and was circulated to the member bodies in December 1979.

It has been approved by the member bodies of the following countries :

Australia	France	Poland
Austria	Germany, F. R.	Portugal
Belgium	Hungary	Romania
Brazil	India	South Africa, Rep. of
Bulgaria	Italy	Switzerland
China	Korea, Rep. of	Thailand
Czechoslovakia	Netherlands	United Kingdom
Egypt, Arab Rep. of	Philippines	USSR

No member body expressed disapproval of the document.

This International Standard has also been approved by the International Union of Pure and Applied Chemistry (IUPAC).

# But-2-ene-1,4-diol for industrial use — Determination of iodine value

## 1 Scope and field of application

This International Standard specifies a titrimetric method for the determination of the iodine value of but-2-ene-1,4-diol (HO.CH<sub>2</sub>.CH : CH.CH<sub>2</sub>.OH) for industrial use.

## 2 Definition

**iodine value** : The number of grams of iodine absorbed by 100 g of a substance under specified conditions of test.

NOTE — The iodine value is a measure of the degree of insaturation and, in this determination, gives an indication of the but-2-ene-1,4-diol content.

## 3 Principle

Treatment of a test solution with an excess of acidified potassium bromide-bromate solution in the presence of mercury(II) sulphate and, after addition of potassium iodide solution, titration of the liberated iodine with standard volumetric sodium thiosulphate solution.

## 4 Reagents

During the analysis, use only reagents of recognized analytical grade and only distilled water or water of equivalent purity.

**4.1 Potassium bromide-bromate**, standard volumetric solution,  $c(1/2 \text{ Br}_2) = 0,1 \text{ mol/l}$ .

Dissolve 15 g of potassium bromide (KBr) and 2,78 g of potassium bromate (KBrO<sub>3</sub>) in water, transfer the solution quantitatively to a 1 000 ml one-mark volumetric flask, dilute to the mark and mix.

**4.2 Mercury(II) sulphate**, approximately 30 g/l solution.

**WARNING** — Very toxic by inhalation, in contact with skin and if swallowed. Danger of cumulative effects. After contact with skin, wash immediately with plenty of water.

In case of accident or feeling unwell, seek medical advice immediately (show the label where possible).

Carefully add, with stirring, 28 ml of sulphuric acid solution, approximately  $\rho$  1,84 g/ml, about 96 % (m/m) solution, to 500 ml of water. Dissolve 30 g of mercury(II) sulphate (HgSO<sub>4</sub>) in this solution and dilute to 1 000 ml.

NOTE — In order to prevent pollution of waste water, collect solutions containing mercury salts and remove mercury, following (for example), the method specified in annex B of ISO 5790, *Inorganic chemical products for industrial use — General method for determination of chloride content — Mercurimetric method*.

**4.3 Sulphuric acid**, approximately 294 g/l solution.

**4.4 Sodium thiosulphate**, standard volumetric solution,  $c(\text{Na}_2\text{S}_2\text{O}_3) = 0,1 \text{ mol/l}$ .

Check the concentration before use.

**4.5 Potassium iodide**, 200 g/l solution.

**4.6 Sodium chloride**, 117 g/l solution.

**4.7 Starch solution**.

Triturate 1,0 g of soluble starch with 5 ml of water and, whilst stirring, pour the mixture into 100 ml of boiling water. Boil for a few minutes and cool.

Discard the solution after 2 weeks.

## 5 Apparatus

Ordinary laboratory apparatus and

**5.1 Bromination flask**, conical, of capacity 300 ml, capable of withstanding vacuum, fitted with a rubber stopper.

**5.2 Dropping funnel**, of capacity 100 ml, capable of withstanding vacuum.

**5.3 Vacuum pump**, capable of achieving a pressure less than 10 kPa\*.

NOTE — A diagram of the assembly is shown in the figure.

## 6 Sampling\*\*

Place the laboratory sample, representative of the material from the bulk, in a clean, dry, ground glass stoppered bottle of such a size that it is nearly filled by the sample.

If it is necessary to seal the bottle, care shall be taken to avoid any risk of contamination.

## 7 Procedure

### 7.1 Test portion

Weigh, to the nearest 0,01 g, approximately 7,3 g of the laboratory sample (clause 6).

### 7.2 Blank test

Carry out a blank test at the same time as the determination using the same procedure and the same quantities of reagents [except the standard volumetric sodium thiosulphate solution (4.4)] as used for the determination, but using 10,0 ml of water instead of 10,0 ml of the test solution (7.3).

### 7.3 Preparation of test solution

Place the test portion (7.1) in a 500 ml one-mark volumetric flask, dissolve in water, dilute to the mark and mix.

### 7.4 Determination

Place 50,0 ml of the potassium bromide-bromate solution (4.1) in the bromination flask (5.1) and fit the dropping funnel (5.2). Evacuate the flask and funnel using the vacuum pump (5.3). Close the stopcock of the funnel and disconnect the vacuum pump. Maintaining the vacuum in the flask and making all additions via the funnel, add 5 ml of the sulphuric acid solution (4.3) and, 2 to 3 min later, 15 ml of the mercury(II) sulphate solution (4.2). Immediately add a 10,0 ml aliquot portion of the test solution (7.3), followed by three 5 ml washings of water.

Shake the flask in the dark for 7 min, introduce 15 ml of the sodium chloride solution (4.6) and 15 ml of the potassium iodide solution (4.5) and shake for a further 30 s. Open the stopcock to release the vacuum, disconnect the funnel, add 50 ml of water and titrate the liberated iodine with the standard volumetric sodium thiosulphate solution (4.4) until the colour of the solution is pale yellow. Add about 2 ml of the starch solution (4.7) and continue the titration until the blue colour is just discharged.

## 8 Expression of results

The iodine value is given by the formula

$$\begin{aligned} & (V_0 - V_1) \times \frac{253,81}{2 \times 10^4} \times 50 \times \frac{100}{m} \\ &= (V_0 - V_1) \times \frac{63,45}{m} \end{aligned}$$

where

$V_0$  is the volume, in millilitres, of the standard volumetric sodium thiosulphate solution (4.4) used for the blank test;

$V_1$  is the volume, in millilitres, of the standard volumetric sodium thiosulphate solution (4.4) used for the determination;

$m$  is the mass, in grams, of the test portion (7.1);

$\frac{253,81}{2 \times 10^4}$  is the mass, in grams, of iodine ( $I_2$ ) corresponding to 1 ml of iodine solution  $c(1/2 I_2) = 0,100 \text{ mol/l}$ .

NOTE — If the concentration of the standard volumetric solutions used is not exactly as specified in the list of reagents, an appropriate correction should be made.

## 9 Test report

The test report shall contain the following information :

- an identification of the sample;
- the reference of the method used;
- the results and the method of expression used;
- any unusual features noted during the determination;
- any operation not included in this International Standard, or regarded as optional.

\* 10 kPa = 100 mbar

\*\* The sampling of liquid chemical products for industrial use will form the subject of a future International Standard.

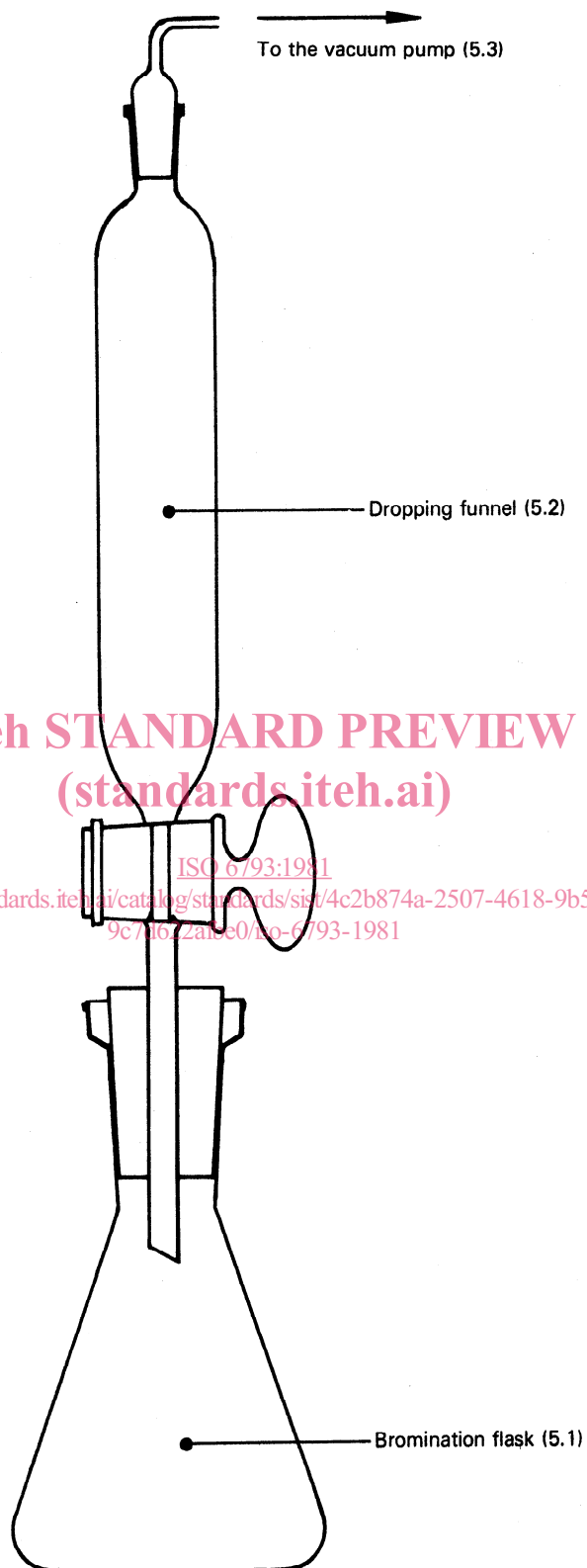

Figure — Diagram of assembled apparatus

**iTeh STANDARD PREVIEW**  
**(standards.iteh.ai)**

This page intentionally left blank

ISO 6793:1981

<https://standards.iteh.ai/catalog/standards/sist/4c2b874a-2507-4618-9b5b-9c7d622afbe0/iso-6793-1981>

**iTeh STANDARD PREVIEW**  
**(standards.iteh.ai)**

This page intentionally left blank

[ISO 6793:1981](#)

<https://standards.iteh.ai/catalog/standards/sist/4c2b874a-2507-4618-9b5b-9c7d622afbe0/iso-6793-1981>

**iTeh STANDARD PREVIEW**  
**(standards.iteh.ai)**

This page intentionally left blank

ISO 6793:1981

<https://standards.iteh.ai/catalog/standards/sist/4c2b874a-2507-4618-9b5b-9c7d622afbe0/iso-6793-1981>