

Revised

ISO

INTERNATIONAL ORGANIZATION FOR STANDARDIZATION

ISO RECOMMENDATION

R 75

PLASTICS

**DETERMINATION OF
TEMPERATURE OF DEFLECTION UNDER LOAD**

1st EDITION

December 1958

COPYRIGHT RESERVED

The copyright of ISO Recommendations and ISO Standards belongs to ISO Member Bodies. Reproduction of these documents, in any country, may be authorized therefore only by the national standards organization of that country, being a member of ISO.

For each individual country the only valid standard is the national standard of that country.

Printed in Switzerland

Also issued in French and Russian. Copies to be obtained through the national standards organizations.

BRIEF HISTORY

The ISO Recommendation R 75, *Plastics - Determination of Temperature of Deflection under Load*, was prepared by Technical Committee ISO/TC 61, *Plastics*, the Secretariat of which is held by the American Standards Association, Incorporated (ASA).

Development of this test method was undertaken at the first meeting of the Technical Committee, held in New York, in September 1951, a digest of U.S.A. information on the subject having been circulated prior to that meeting. The study was assigned to Working Group No. 4, *Thermal Properties*.

The draft formulated by the Working Group was presented to the Technical Committee at its third plenary meeting, held in Stockholm, in August 1953, and then distributed to the members of the Technical Committee as a draft proposal for an ISO Recommendation.

After its reconsideration at the fourth meeting of ISO/TC 61, held in Brighton, in October 1954, the draft proposal was adopted as a Draft ISO Recommendation.

On 31 December 1955, the Draft ISO Recommendation was circulated to all the ISO Member Bodies and, some amendments having been taken into consideration, it was approved by the following 27 Member Bodies (out of a total of 37):

Australia	India	Portugal
Austria	Ireland	Spain
Bulgaria	Israel	Sweden
Chile	Italy	Turkey
Czechoslovakia	Japan	Union of South Africa
*Denmark	Mexico	United Kingdom
Finland	Netherlands	U.S.A.
France	Pakistan	U.S.S.R.
*Greece	Poland	Yugoslavia

No Member Body opposed approval of the Draft.

The Draft ISO Recommendation was then submitted, by correspondence, to the ISO Council, which decided, in December 1958, to accept it as an ISO RECOMMENDATION.

* These Member Bodies stated that they had no objection to the Draft being approved.

PLASTICS
DETERMINATION OF
TEMPERATURE OF DEFLECTION UNDER LOAD

1. SCOPE

- 1.1 This method of test is suitable for plastics materials which are rigid at a room temperature of 20 to 23 °C.
- 1.2 This method of test covers a procedure for determining the temperature at which an arbitrary deformation occurs when the test specimens are subjected to arbitrary bending loads, under conditions of continually rising temperatures. Data obtained by this method may be used to predict the behaviour of plastics materials at elevated temperatures only in applications in which the factors of time, temperature, method of loading and fibre stress are similar to those specified in this ISO Recommendation. This test method is suited to the determination of, and the control of, the quality of plastics materials. The results obtained do not represent maximum use temperatures because of the variables referred to above.
- 1.3 This method applies to moulded materials in thicknesses between 3.0 and 4.2 mm and to materials in sheet form in thicknesses ranging from 3 to 13 mm.

2. APPARATUS

- 2.1 **The apparatus** used is constructed essentially as shown in the figure (page 4) and should conform to the description given below.
- 2.2 **Specimen supports.** The specimen rests horizontally on metal supports which are 100 mm \pm 2.0 mm apart, with the load applied on top of the specimen, vertically and midway between the supports, by means of a rod. The contact edges of the supports and of the rod by which pressure is applied are rounded to a radius of 3.0 mm \pm 0.2 mm. The vertical members which attach the specimen supports to the upper plate are made of material having the same coefficient of linear expansion as is used for the rod (see Note 1).

Note 1. Unless these parts have the same coefficient of linear expansion, the differential change in length of these parts introduces an error in the reading of the apparent deformation of the specimen. A blank test is made on each apparatus using a test bar made of rigid material having a low coefficient of expansion. * The temperature ranges to be used should be covered and a correction factor determined for each temperature. If the correction factor is 0.010 mm or greater, its algebraic sign is noted and the factor is applied to each test by adding it algebraically to the reading of apparent deflection of the test specimens.

* Invar or borosilicate glass has been found suitable for this purpose.

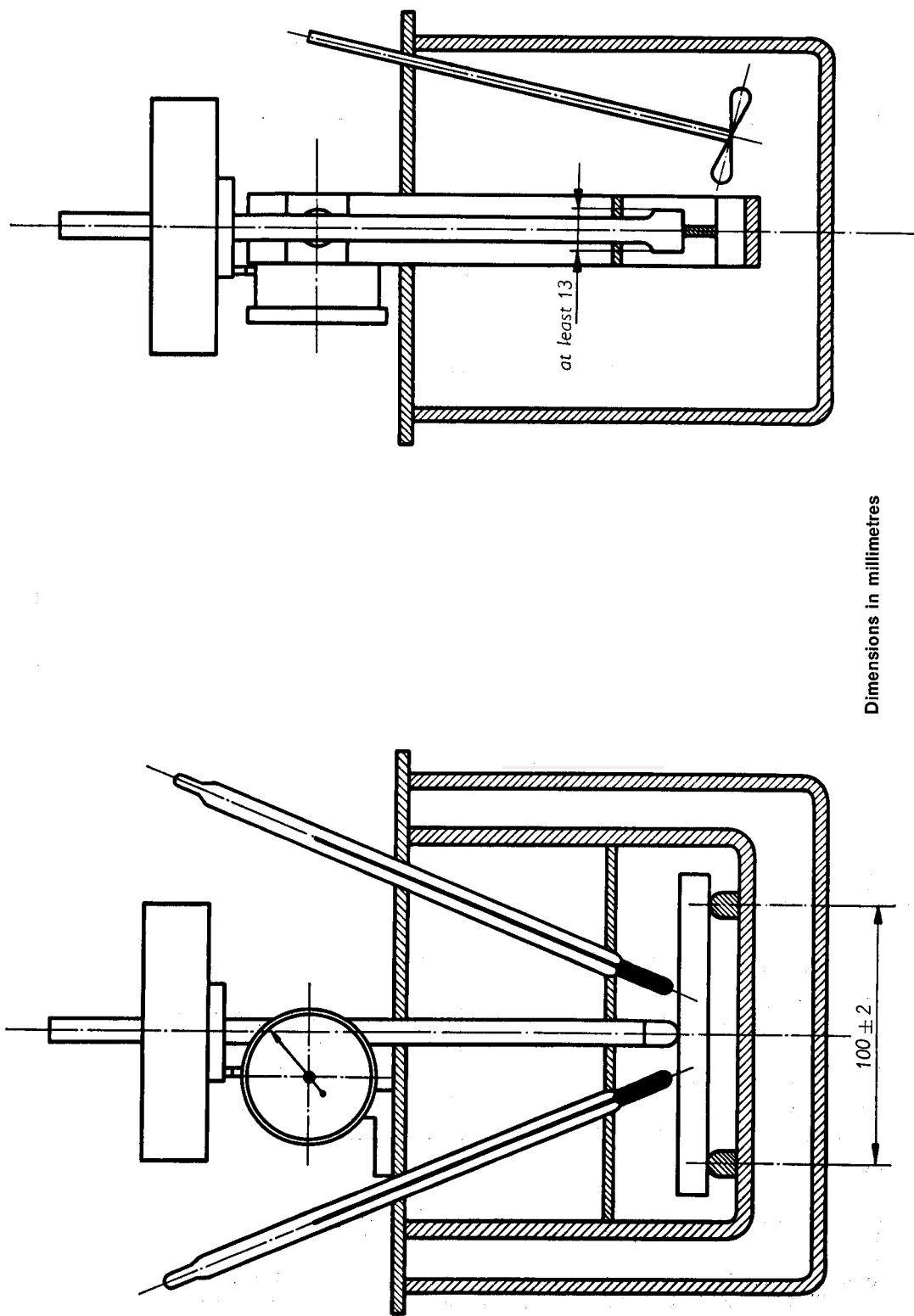

APPARATUS FOR DETERMINATION OF TEMPERATURE OF DEFLECTION UNDER LOAD

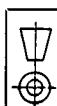

- 2.3 Immersion bath.** The specimen is immersed in a suitable liquid heat-transfer medium (see Notes 2 and 3). It is well stirred during the test and provided with a means of raising the temperature at an average rate of 2 degrees Celsius per minute and the temperature should not deviate from the average by more than ± 1 degree Celsius at any time.

Note 2. A liquid heat-transfer medium is chosen which is stable at the temperatures used, and which does not affect the specimen at the temperatures used. Mineral oil has been found suitable for many plastics materials.

Note 3. If no suitable liquid can be found for use as a heat-transfer medium, as defined in Note 2, this test method should not be used. Some different method, for which air may be found to be a suitable heat-transfer medium, should be used.

- 2.4 Weights.** A set of weights of suitable sizes is made available so that the specimen can be loaded to a fibre stress either of

18.5 kgf/cm² for Method A, or of
4.6 kgf/cm² for Method B.

The weight of the rod which applies the testing force is determined and included as part of the total load. If a dial gauge is used, the force exerted by its spring is determined and included as part of the total load (see Notes 4 and 5).

The load is calculated from the following formula:

$$F = \frac{2 \sigma b d^2}{3 l}$$

where

F = load in kilogrammes-force;

σ = maximum fibre stress in specimen: —
18.5 kgf/cm² when tested according to Method A,
4.6 kgf/cm² when tested according to Method B;

b = width of specimen in centimetres;

d = depth of specimen in centimetres;

l = width of span between supports in centimetres.

The actual load applied is the calculated load ± 2.5 per cent. All dimensions used in the calculation are measured to the nearest 0.1 mm.

Note 4. In certain forms of execution of the apparatus, the force of the dial gauge spring is directed upward and must be subtracted from the load, while in other forms this force acts downward and must be added to the load.

Note 5. Since the force exerted by the spring in certain dial gauges varies considerably over the stroke, this force is measured in that part of the stroke which is to be used.

- 2.5 Thermometers.** The thermometers are mercury in glass thermometers of the partial immersion type, graduated in degrees Celsius. The graduation marks should permit reading one degree Celsius, and a scale error at any reading should not exceed 0.5 degree Celsius. The thermometers are immersed to the depth for which they have been calibrated and which should not be less than 50 mm.

3. PREPARATION OF APPARATUS

- 3.1 The apparatus is arranged so that the deflection of the midpoint of the specimen can be measured on a scale calibrated in hundredths of a millimetre. The apparatus may be arranged to shut off the heat automatically and sound an alarm when the specified deflection has been reached.

4. TEST SPECIMENS

- 4.1 At least two specimens are used to test each sample. The specimens are 110 mm (minimum) in length, between 3.0 and 4.2 mm in width, and between 9.8 and 12.8 mm in depth, except for materials in sheet form, * in which case the width of the specimen is in the range of 3 to 13 mm.
- 4.2 The test results obtained on moulded specimens depend on the moulding conditions used in their preparation. Moulding conditions should therefore be agreed to by all parties concerned.
- 4.3 Discrepancies in test results due to variations in moulding conditions may be minimized by annealing the specimens before test. Since different materials require different annealing conditions, annealing procedures should be employed only if agreed to by all parties concerned.

5. CONDITIONING TEST SPECIMENS

- 5.1 The specimens are conditioned in accordance with the procedures specified for each material, or with procedures agreed to by all parties concerned.

6. PROCEDURE

- 6.1 **Method A.** The test specimen is placed in the apparatus with its depth (as defined in clauses 2.4 and 4.1) in a vertical plane. In case of bars, either compression moulded or cut from moulded sheets, the bars are so placed that the direction of the testing force is perpendicular to the direction of the moulding pressure. The thermometers extend to within 2 mm of the specimen, but do not touch it. The temperature of the bath is 20 to 23 °C at the start of each test, unless previous tests have shown that, for the particular materials under test, no error is introduced by starting at other temperatures. The load is adjusted to give a fibre stress of 18.5 kgf/cm², as calculated by the formula given in clause 2.4. The load is allowed to act for 5 min (see Note 6, page 7); the zero reading or setting of the measuring device is then made and the heating started. This waiting period may be omitted when testing materials which show no appreciable creep during the initial 5 min. Tests are conducted by raising the temperature of the bath, as required in clause 2.3. The temperature at which the bar has reached the standard deflection corresponding to the depth of the test specimen, as given in the table (clause 6.1.1), is reported as the temperature of deflection under load at 18.5 kgf/cm² fibre stress.

* Only in the case of materials in sheet form may the width of test specimens (which dimension is ordinarily the thickness of the sheet) lie between 3 and 13 mm. Work is in progress to determine whether or not this wide range of specimen widths gives satisfactory results for those plastics materials commonly available in sheet form.

6.1.1 Standard deflections

Depth of test bar Millimetres	Standard deflection Millimetres
9.8 to 9.9	0.33
10.0 to 10.3	0.32
10.4 to 10.6	0.31
10.7 to 10.9	0.30
11.0 to 11.4	0.29
11.5 to 11.9	0.28
12.0 to 12.3	0.27
12.4 to 12.7	0.26
12.8	0.25

- 6.2 Method B.** The test is conducted exactly as described for Method A (clause 6.1), except that the load is adjusted to give a fibre stress of 4.6 kgf/cm^2 , as calculated by the formula given in clause 2.4. The temperature at which the bar has reached the standard deflection corresponding to the depth of the test specimen, as given above, is reported as the temperature of deflection under load at 4.6 kgf/cm^2 fibre stress.

Note 6. The 5 min waiting period is provided to compensate partially for the creep exhibited by several materials at room temperature when subjected to the prescribed fibre stress. That part of the creep which occurs in the initial 5 min is usually a large fraction of that which occurs in the first 30 min.

7. REPORT

- 7.1** The report includes the following:

- (a) The width and depth of the specimen measured to the nearest 0.1 mm;
- (b) The temperature of deflection under load for each test specimen in degrees Celsius and the fibre stress;
- (c) The immersion medium;
- (d) The conditioning procedure used;
- (e) The moulding and annealing procedures used, where applicable;
- (f) Any peculiar characteristics of the specimen noted during the test or after removal from the apparatus.