



Designation: G 47 – 98

Standard Test Method for Determining Susceptibility to Stress-Corrosion Cracking of 2XXX and 7XXX Aluminum Alloy Products¹

This standard is issued under the fixed designation G 47; the number immediately following the designation indicates the year of original adoption or, in the case of revision, the year of last revision. A number in parentheses indicates the year of last reapproval. A superscript epsilon (ε) indicates an editorial change since the last revision or reapproval.

This standard has been approved for use by agencies of the Department of Defense.

1. Scope

1.1 This test method covers a uniform procedure for characterizing the resistance to stress-corrosion cracking (SCC) of high-strength aluminum alloy wrought products for the guidance of those who perform stress-corrosion tests, for those who prepare stress-corrosion specifications, and for materials engineers.

1.2 This test method covers method of sampling, type of specimen, specimen preparation, test environment, and method of exposure for determining the susceptibility to SCC of 2XXX (with 1.8 to 7.0 % copper) and 7XXX (with 0.4 to 2.8 % copper) aluminum alloy products, particularly when stressed in the short-transverse direction relative to the grain structure.

1.3 The values stated in SI units are to be regarded as standard. The inch-pound units in parentheses are provided for information.

1.4 *This standard does not purport to address all of the safety concerns, if any, associated with its use. It is the responsibility of the user of this standard to establish appropriate safety and health practices and determine the applicability of regulatory limitations prior to use.*

2. Referenced Documents

2.1 ASTM Standards:

G 38 Practice for Making and Using the C-Ring Stress-Corrosion Test Specimens²

G 44 Practice for Evaluating Stress Corrosion Cracking Resistance of Metals and Alloys by Alternate Immersion in 3.5% Sodium Chloride Solution²

G 49 Practice for Preparation and Use of Direct Tension Stress Corrosion Test Specimens²

G 139 Test Method for Determining the Stress-Corrosion Cracking Resistance of Heat Treatable Aluminum Alloy Products Using the Breaking Load Method²

¹ This test method, which was developed by a joint task group with the Aluminum Association, Inc., is under the jurisdiction of ASTM Committee G-1 on Corrosion of Metals, and is the direct responsibility of Subcommittee G01.06 on Stress Corrosion Cracking and Corrosion Fatigue.

Current edition approved Apr. 10, 1998. Published October 1998. Originally published as G 47 – 76. Last previous edition G 47 – 90.

² *Annual Book of ASTM Standards*, Vol 03.02.

3. Summary of Test Method

3.1 This test method provides a comprehensive procedure for accelerated stress-corrosion testing high-strength aluminum alloy product forms, particularly when stressed in the short-transverse grain direction. It specifies tests of constant-strain-loaded, 3.18-mm (0.125-in.) tension specimens or C-rings exposed to 3.5 % sodium chloride (NaCl) solution by alternate immersion, and includes procedures for sampling various manufactured product forms, examination of exposed test specimens, and interpretation of test results.

4. Significance and Use

4.1 The 3.5 % NaCl solution alternate immersion test provides a test environment for detecting materials that would be likely to be susceptible to SCC in natural outdoor environments, especially environments with marine influences.^{3,4,5} For determining actual serviceability of a material, other stress-corrosion tests should be performed in the intended service environment under conditions relating to the end use, including protective measures.

4.2 Although this test method is intended for certain alloy types and for testing products primarily in the short-transverse stressing direction, this method is useful for some other types of alloys and stressing directions.

5. Interferences

5.1 A disadvantage of the 3.5 % NaCl solution alternate immersion test is that severe pitting may develop in the specimens. Such pitting in tension specimens with relatively small cross section can markedly reduce the effective cross-sectional area and produce a net section stress greater than the

³ Romans, H. B., *Stress Corrosion Testing*, ASTM STP 425, ASTM, 1967, pp. 182–208.

⁴ Brown, R. H., Sprowls, D. O., and Shumaker, M. B., “The Resistance of Wrought High Strength Aluminum Alloys to Stress Corrosion Cracking,” *Stress Corrosion Cracking of Metals—A State of the Art*, ASTM STP 518, ASTM, 1972, pp. 87–118.

⁵ Sprowls, D. O., Summerson, T. J., Ugiansky, G. M., Epstein, S. G., and Craig, H. L., Jr., “Evaluation of a Proposed Standard Method of Testing for Susceptibility to Stress-Corrosion Cracking of High-Strength 7XXX Series Aluminum Alloy Products,” *Stress Corrosion-New Approaches*, ASTM STP 610, ASTM, 1976, pp. 3–31.

nominal gross section stress, resulting in either: (a) fracture by mechanical overload of a material that is not susceptible to SCC; or (b) SCC of a material at an actual stress higher than the intended nominal test stress. The occurrence of either of these phenomena might then interfere with a valid evaluation of materials with relatively high resistance to stress corrosion.

6. Test Specimen

6.1 *Type and Size*—No single configuration of test specimen is applicable for the many complex shapes and sizes of products that must be evaluated. A tension specimen is preferred because it more consistently provides definite evidence of cracking and should be used whenever the size and shape of the product permits; it also provides a more severe test.

6.1.1 *Tension Specimen*—The diameter of the reduced section shall be 3.17 ± 0.03 mm (0.125 ± 0.001 in.).

6.1.2 *C-Ring (see Practices G 38)*—The use of C-rings permits short-transverse tests to be made of sections that are too thin or complex for practical tests with a tension specimen. C-rings may be of various sizes as required for the product to be tested, but in no case less than 15.88 ± 0.05 mm (0.625 ± 0.002 in.) in outside diameter. The ratio of diameter to wall thickness shall be kept in the range from 11:1 to 16:1.

6.2 *Stressing Direction:*

6.2.1 *Short-Transverse Tests:*

6.2.1.1 For specified material thicknesses of 38.10 mm (1.500 in.) and over, the tension specimen shall be used.

6.2.1.2 For specified material thicknesses of 17.78 through 38.08 mm (0.700 through 1.499 in.), a C-ring shall be used. A tension specimen may be used if consistent with the provisions of Practice G 49.

6.2.2 For other stress directions in materials of 6.35 mm (0.250 in.) and over, the tension specimen shall be used.

6.3 *Surface Preparation*—Test specimens shall be degreased prior to exposure.

7. Sampling and Number of Tests

7.1 Unless otherwise specified, tests shall be performed in the short-transverse direction; the intention is to orient the specimen so that the applied tensile stress is perpendicular to the metal flow lines and in the short-transverse direction relative to the grain structure. In rolled or extruded sections that are approximately round or square, there is no true short-transverse direction because in a transverse plane the grains tend to be equiaxial; and, in such cases, the stress should be directed simply in the transverse direction. If, in certain unusual cases, the grain structure is or tends to be equiaxial also in the longitudinal direction, the stress shall be applied in a direction parallel to the smallest dimension of the product.

7.2 *Location of Specimens:*

7.2.1 For products stress relieved by stretching (TX51, TX510, TX511, TXX51, TXX510, TXX511), samples shall not be taken from the portion under the stretcher grips.

7.2.2 *Rolled Plate*—Short-transverse specimens shall be taken so that the region of maximum stress is centered on the mid-plane of the plate and at least $2\frac{1}{2}$ plate thicknesses away from a side of the plate. (The side of the plate is defined as the edge parallel to the rolling direction.)

7.2.3 *Hand Forgings*—Short-transverse specimens shall be taken so that the stress is applied in a direction perpendicular to the forging flow lines. The region of maximum stress shall be centered in the forging thickness and approximately on the longitudinal center line of the forging, no less than $\frac{1}{2}$ the section thickness away from “as-heat treated” edges of the forging.

7.2.4 *Die Forgings*—Because of the wide variety of configurations of die forgings, guidelines are provided for only certain common types of shapes that are widely used. Short-transverse specimens shall be taken so that the stress is applied in a direction perpendicular to the forging flow lines and, if possible, with the region of maximum stress centered on the parting plane. The metal flow pattern in die forgings cannot always be predicted, so only a few general rules are given, and they are illustrated in Fig. 1. Departures from these rules should be made only on the basis of a study of forging flow lines indicating that the intended type of test would not be obtained. In every case, a diagram should be filed with the test results to illustrate specimen locations and orientations.

7.2.4.1 *Flanges*—The centerline of the specimen shall be 12.70 ± 1.27 mm (0.500 ± 0.050 in.) from the base of the fillet of the flash except for flanges that are too thin, in which case, the specimen should be centered.

7.2.4.2 *Flat-Top Die*—The tension specimen should be perpendicular to the parting plane and, if possible, centered in the width.

7.2.4.3 *Boss or Small Cylinder*—The C-ring specimen should be centered on the parting plane and with the outside

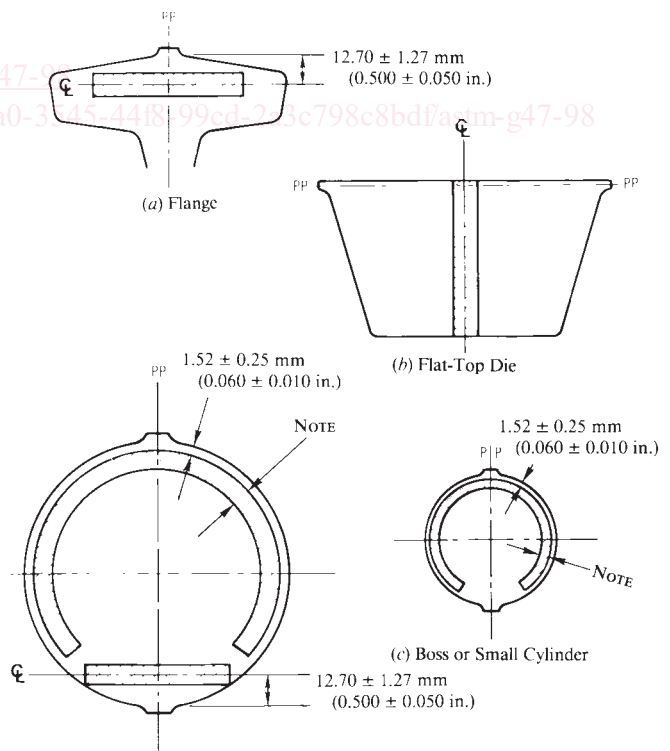

NOTE 1—Similar to that of typical machined part.

FIG. 1 Recommended Specimen Type and Location for Various Configurations of Die Forgings

diameter of the ring being 1.52 ± 0.25 mm (0.060 ± 0.010 in.) from the forging surface (see Fig. 1).

7.2.4.4 Large Cylinder—The centerline of tension specimens shall be 12.70 ± 1.27 mm (0.500 ± 0.050 in.) from the base of the flash. If a C-ring is required, its outside diameter shall be 1.52 ± 0.25 mm (0.060 ± 0.010 in.) from the forging surface (see Fig. 1).

7.2.5 Extruded, Rolled, or Cold Finished Rod, Bar, and Shapes:

7.2.5.1 Width-to-Thickness Ratio Greater than 2—Short-transverse specimens shall be taken so that the region of maximum stress is centered in the section thickness, at least one section thickness away from the sides of the product. In the case of complex configurations for which the grain directionality cannot be predicted, specimen location shall be determined by means of macroetched transverse sections to ensure a short-transverse specimen and to avoid regions of nearly equiaxial (transverse) grain flow.

7.2.5.2 Width-to-Thickness Ratio of 2 or Less—Specimens shall be centered in the section thickness so that the region of maximum stress application will be at least one half the section thickness away from a fabricated surface, if possible. These specimens shall be considered to have a “transverse” orientation to the grain structure. When C-rings are required, they shall be taken so that the region of maximum tensile stress is 3.18 ± 0.25 mm (0.125 ± 0.010 in.) from the product surface.

7.3 Number of Specimens—For each sample, which shall be uniform in thickness and grain structure, a minimum of three adjacent replicate specimens shall be tested.

8. Test Environment

8.1 Corrosion Test Environment—Specimens shall be exposed to the alternate 10-min immersion—50-min drying cycle in accordance with Practice G 44.

8.2 Length of Exposure—The test duration for 3.18-mm (0.125-in.) tension specimens and C-rings shall be 10 days for 2XXX alloys or 20 days for 7XXX alloys, unless cracking occurs sooner. For specimens to be tested in the long transverse direction, the test duration should be 40 days. Longer non-standard test durations are likely to cause failures of the 3.18-mm tension specimens as a result of severe pitting as described in 5.1. There shall be no interruptions except as required for periodic inspection of specimens or changing of the solution.

9. Procedure

9.1 Method of Loading:

9.1.1 Tension Specimens—Stress tension specimens in “constant strain”-type fixtures, as in Fig. 3 of Practice G 49.

9.1.2 C-rings—Stress C-rings by a method that provides constant strain and produces a tensile stress on the ring outside diameter in accordance with Practice G 38.

9.2 Magnitude of Applied Stress—Stress specimens to one or more levels as specified or as required to determine comparative stress corrosion resistance. The application of a stress less than about 103 MPa (15 ksi) is not practicable.

9.3 Examination of Specimens:

9.3.1 Interim Inspection:

Visually inspect specimens each working day for evidence of cracking without removal of corrosion products. Inspection may be facilitated by wetting the specimen with the test solution and by examination at low magnifications.

9.3.2 Final Examination—Perform final examination at a magnification of at least 10X on all surviving specimens after cleaning them in concentrated (70%) nitric acid (HNO_3) at room temperature followed by a water rinse. Section and metallographically examine any C-ring that is considered suspect, as evidenced by linear pitting, to determine whether or not SCC is present. Similar examination of fractured or cracked tension specimens also can be useful to verify SCC as the cause of failure.

10. Interpretation of Results

10.1 Criterion of Failure:

10.1.1 A sample shall be considered to have failed the test if one or more of the specimens fail, except that the retest provisions of Section 11 shall apply.

10.1.2 A specimen that has fractured or which exhibits cracking shall be considered as a stress corrosion failure unless proved otherwise by the provisions of 10.2 and 10.3.

10.2 Macroscopic Examination—Cracking should be clearly differentiated from lined-up pitting. If the presence of SCC is questionable, metallographic examinations should be performed to determine whether or not SCC is present.

NOTE 1—When a specimen fractures within a relatively short time after exposure (ten days or less), metallographic examination is not necessary because such rapid failures are characteristically due to SCC.

10.3 Metallographic Examination:

10.3.1 A specimen that reveals intergranular cracking, even when accompanied by transgranular cracking, shall be considered as an SCC failure. Intergranular fissures that are no deeper than the width of localized areas of intergranular corrosion or, in the case of C-rings, not deeper than those in unstressed or compressively stressed surfaces, shall not be considered as an SCC failure. In the case of tension specimens, the depth of intergranular fissures may be compared to those in an unstressed specimen when available.

10.3.2 A specimen that reveals only pitting corrosion (that is, no intergranular attack), or pitting plus transgranular cracking, shall not be considered as an SCC failure.

NOTE 2—Transgranular cracking in the absence of intergranular attack only occurs in pitted specimens under extremely high stress (intensity) and, for the purpose of this text method, is not considered as a criterion of SCC.

11. Retesting and Resampling

11.1 Retesting shall be permitted only if a single specimen fails by SCC, in which case three replicate specimens shall be tested. If any retest specimen fails, the sample shall be considered to have failed the test.

11.2 If any failure is due to improper preparation of the specimen or to incorrect testing technique, or if the specimen is found to be not representative of the material, the specimen shall be discarded and another specimen substituted.