

INTERNATIONAL STANDARD

**ISO
6804**

Second edition
1991-07-15

Rubber hoses and hose assemblies for washing-machines and dishwashers — Specification for inlet hoses

iTeh STANDARD PREVIEW

*Tuyaux et flexibles en caoutchouc pour l'alimentation des machines à
laver et lave-vaisselle — Spécifications*

ISO 6804:1991

<https://standards.itih.ai/catalog/standards/sist/28cfl6fd-325d-4378-982d-14b3ef1b47b2/iso-6804-1991>

INTERNATIONAL

ISO



Reference number
ISO 6804:1991(E)

Foreword

ISO (the International Organization for Standardization) is a worldwide federation of national standards bodies (ISO member bodies). The work of preparing International Standards is normally carried out through ISO technical committees. Each member body interested in a subject for which a technical committee has been established has the right to be represented on that committee. International organizations, governmental and non-governmental, in liaison with ISO, also take part in the work. ISO collaborates closely with the International Electrotechnical Commission (IEC) on all matters of electrotechnical standardization.

Draft International Standards adopted by the technical committees are circulated to the member bodies for voting. Publication as an International Standard requires approval by at least 75% of the member bodies casting a vote.

International Standard ISO 6804 was prepared by Technical Committee ISO/TC 45, *Rubber and rubber products*.

This second edition cancels and replaces the first edition (ISO 6804:1982), clauses 1, 5 and 6 of which have been technically revised. The requirements for hoses for heated and unheated water are now stated separately, and a new figure (figure 4) has been added to illustrate the mandrel used to determine the mechanical resistance of thermoplastics coupling nuts.

© ISO 1991

All rights reserved. No part of this publication may be reproduced or utilized in any form or by any means, electronic or mechanical, including photocopying and microfilm, without permission in writing from the publisher.

International Organization for Standardization
Case Postale 56 • CH-1211 Genève 20 • Switzerland

Printed in Switzerland

Rubber hoses and hose assemblies for washing-machines and dishwashers — Specification for inlet hoses

1 Scope

This International Standard specifies requirements for inlet rubber hoses and hose assemblies for washing-machines and dishwashers connected to the domestic water supply at a pressure not exceeding 1 MPa (10 bar).

It is applicable to the following types of hose:

Type 1: for unheated water supply only.

Type 2: for heated water supply (maximum temperature 90 °C).

There may be national requirements for hose fittings and hoses conveying drinking water which must be complied with.

2 Normative references

The following standards contain provisions which, through reference in this text, constitute provisions of this International Standard. At the time of publication, the editions indicated were valid. All standards are subject to revision, and parties to agreements based on this International Standard are encouraged to investigate the possibility of applying the most recent editions of the standards indicated below. Members of IEC and ISO maintain registers of currently valid International Standards.

ISO 188:1982, *Rubber, vulcanized — Accelerated ageing or heat-resistance tests.*

ISO 471:1983, *Rubber — Standard temperatures, humidities and times for the conditioning and testing of test pieces.*

ISO 1307:1983, *Rubber and plastics hoses — Bore diameters and tolerances on length.*

ISO 1402:1984, *Rubber and plastics hoses and hose assemblies — Hydrostatic testing.*

ISO 1746:1983, *Rubber or plastics hoses and tubing — Bending tests.*

ISO 7326:1991, *Rubber and plastics hoses — Assessment of ozone resistance under static conditions.*

ISO 8033:1985, *Rubber and plastics hose — Determination of adhesion between components.*

3 Materials and construction

3.1 Lining

The lining shall be made of rubber resistant to the conveyed water.

3.2 Reinforcement

The reinforcement shall be made of natural or synthetic textile material.

3.3 Cover

The cover shall be made of ozone-resistant rubber.

4 Dimensions and tolerances

4.1 Nominal bore

Preferred values for the nominal bore of the hose are 10 mm and 12,5 mm.

Tolerances are dependent on the characteristics of fittings; consequently, they shall be as agreed between the manufacturer of the hose and the constructor of the hose assembly, but shall not exceed the maximum tolerances as specified in ISO 1307.

4.2 Length

Tolerances on length shall be in accordance with ISO 1307.

5 Performance requirements

5.1 Bend test

The test shall be carried out at a standard temperature as specified in ISO 471.

When tested in accordance with ISO 1746 method A, under a bend radius of 7,5 times the nominal diameter, the hose assembly shall never show a T/D ratio of less than 0,8.

5.2 Resistance to kinking

The test shall be carried out at a standard temperature as specified in ISO 471.

The hose assembly is folded through an angle of 180° and then pressed in such a way that the total thickness is equal to twice the outside diameter of the hose, as shown in figure 1.

The pressure is maintained for 5 s, after which the hose assembly is allowed to rest for 1 min.

The test is made 10 times at the same point, the fold being made in the same direction each time.

After the test, the hose assembly shall comply with the requirements of 5.3.

5.3 Resistance to hydrostatic pressure after ageing

The hose assembly, filled with water, shall be aged for 7 days (168 h) in an oven, in accordance with ISO 188, at

70 °C ± 2 °C for type 1 hoses;

90 °C ± 2 °C for type 2 hoses.

After ageing, the hose assembly shall be again filled with water at the specified temperature and then tested at a pressure of 3,15 MPa (31,5 bar) by the method specified in ISO 1402 for 1 min.

During the pressure test, the hose assembly shall not burst or show defects such as leakages or blisters, nor shall there be evidence of coupling slippage.

5.4 Resistance to ozone

The test shall be carried out in accordance with ISO 7326, method 1.

The sample of hose shall be tested in an atmosphere having an ozone concentration of 50 pphm at 40 °C ± 2 °C for 72 h.

When viewed under a magnification of × 2, the cover shall show no evidence of cracking.

5.5 Resistance to impulses

The hose assembly is filled with water having a temperature of

25 °C ± 2 °C for type 1 hoses;

90 °C ± 2 °C for type 2 hoses.

The hose assembly is then subjected to 25 000 sinusoidal pulses with a lower pressure of 1 MPa (10 bar) and an upper pressure of 2 MPa (20 bar) in an arrangement as shown in figure 2, the thermostat being adjusted so that the temperature in the cabinet is maintained within the limits specified for the water inside the hose assembly. The hose assembly is mounted in a looped configuration with a loop diameter of about 300 mm. The pulse frequency, as shown in figure 3, shall be 0,5^{+0,1}₀ Hz.

During the test, the hose assembly shall not burst or show defects such as leakages or blisters, nor shall there be evidence of coupling slippage.

5.6 Adhesion

The hose assembly shall be tested in accordance with ISO 8033, and the minimum adhesion between adjacent components shall be 1,5 kN/m.

5.7 Mechanical resistance of thermoplastics coupling nuts

Thermoplastics coupling nuts of hose assemblies shall have adequate mechanical strength.

Compliance is checked by the following test, which is carried out at a standard temperature as specified in ISO 471.

Before starting the test, the coupling nuts are conditioned for 3 days (72 h) at a temperature of 23 °C ± 2 °C and a relative humidity between 45 % and 55 %.

The nut is screwed on to a hardened-steel mandrel as shown in figure 4, the maximum torque applied being 15 N·m.

During the test, the nut shall not break.

After removal of the nut, it shall show no cracks visible to the naked eye and shall be fit for further use.

6 Marking

6.1 Hoses shall be continuously and durably marked with the following information:

- the reference number of this International Standard;
- the nominal bore size;
- the type (i.e. type 1 or type 2);

- the manufacturer's name or mark;
- the year and quarter of manufacture.

EXAMPLE

ISO 6804/10 mm/type 2/MN/1991/3

6.2 At least one fitting shall be marked with the hose assembly constructor's name or mark.

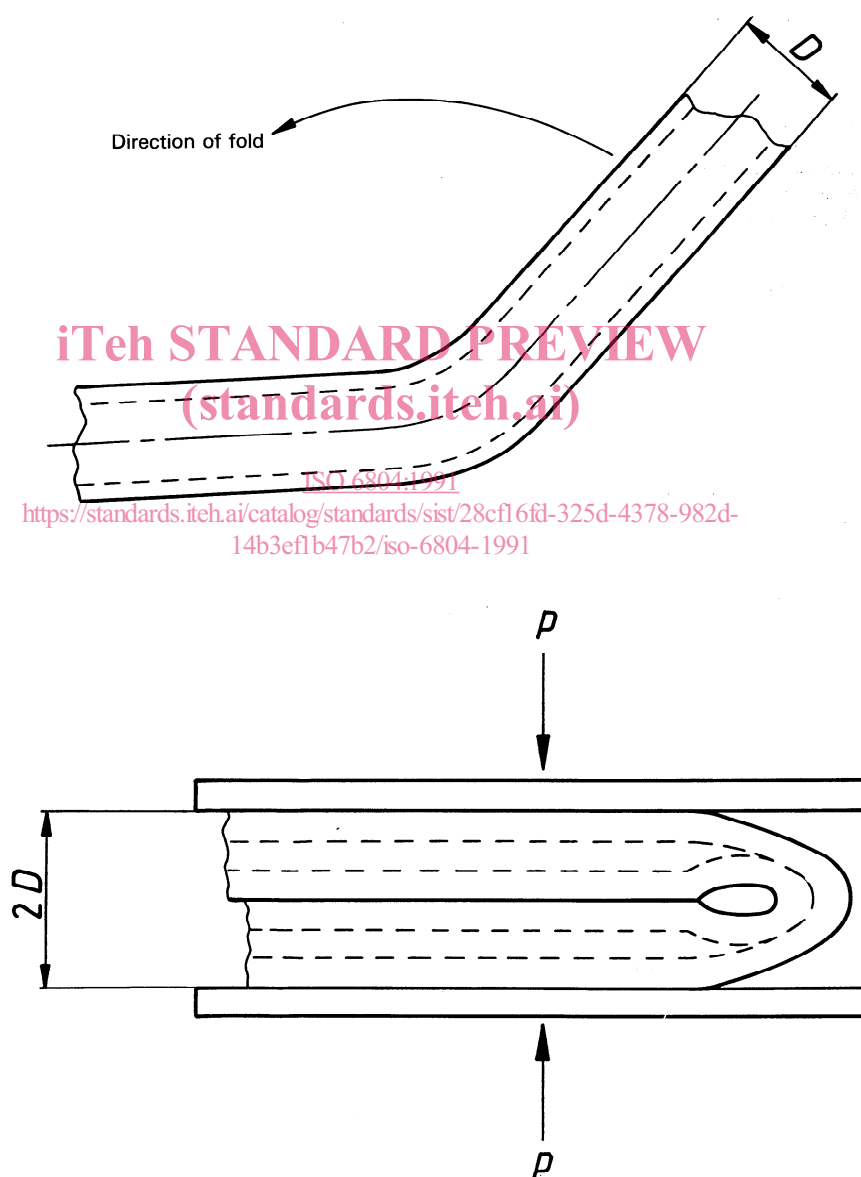
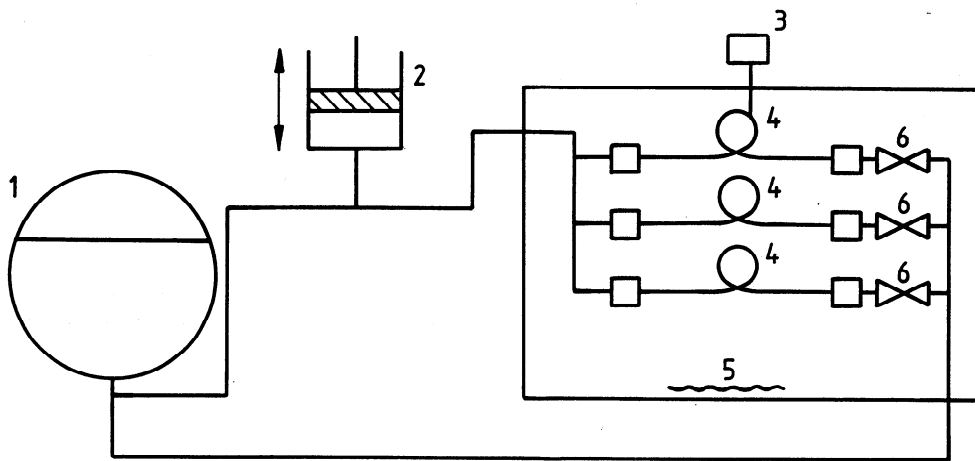

Figure 1 — Test for resistance to kinking



- 1 Pressure reservoir
- 2 Impulse generator
- 3 Thermostat
- 4 Hose assemblies mounted in looped configuration
- 5 Heating element
- 6 Safety valves

Figure 2 — Equipment for testing resistance to impulses

iTeh STANDARD PREVIEW
(standards.iteh.ai)

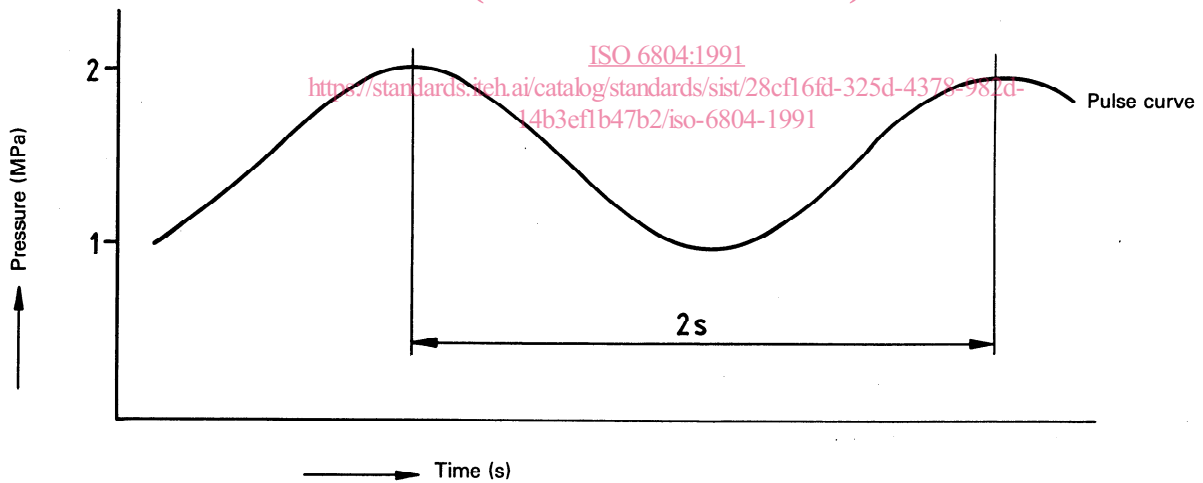

Figure 3 — Pressure pulse diagram

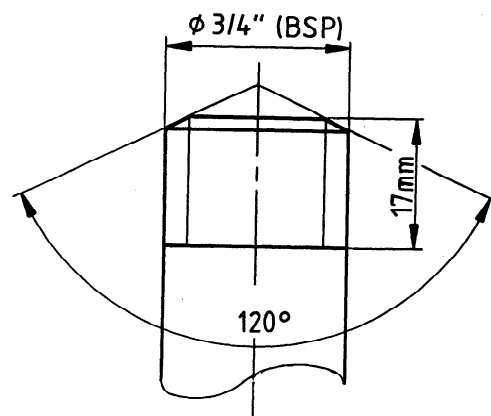

Figure 4 — Mandrel for coupling-nut test

iTeh STANDARD PREVIEW
(standards.iteh.ai)

ISO 6804:1991

<https://standards.iteh.ai/catalog/standards/sist/28cfl6fd-325d-4378-982d-14b3ef1b47b2/iso-6804-1991>

iTeh STANDARD PREVIEW
(standards.iteh.ai)

ISO 6804:1991

<https://standards.iteh.ai/catalog/standards/sist/28cf16fd-325d-4378-982d-14b3ef1b47b2/iso-6804-1991>

UDC 621.643.3.031-036.4:[648.23 + 648.54]

Descriptors: washing machines, dishwashing machines, hoses, rubber hoses, specifications, dimensions, tests, marking.

Price based on 5 pages
