



Designation: F 1801 – 97

## Standard Practice for Corrosion Fatigue Testing of Metallic Implant Materials<sup>1</sup>

This standard is issued under the fixed designation F 1801; the number immediately following the designation indicates the year of original adoption or, in the case of revision, the year of last revision. A number in parentheses indicates the year of last reappraisal. A superscript epsilon ( $\epsilon$ ) indicates an editorial change since the last revision or reappraisal.

### 1. Scope

1.1 This practice covers the procedure for performing corrosion fatigue tests to obtain  $S-N$  fatigue curves or statistically derived fatigue strength values, or both, for metallic implant materials. This practice describes the testing of axially loaded fatigue specimens subjected to a constant amplitude, periodic forcing function in saline solution at 37°C and in air at room temperature. The environmental test method for implant materials may be adapted to other modes of fatigue loading such as bending or torsion. While this practice is not intended to apply to fatigue tests on implantable components or devices, it does provide guidelines for fatigue tests with standard specimens in an environment related to physiological conditions.

1.2 The values stated in SI units are to be regarded as the standard.

1.3 *This standard does not purport to address all of the safety concerns, if any, associated with its use. It is the responsibility of the user of this standard to establish appropriate safety and health practices and determine the applicability of regulatory limitations prior to use.*

### 2. Referenced Documents

#### 2.1 ASTM Standards:

- E 4 Practices for Force Verification of Testing Machines<sup>2</sup>
- E 466 Practice for Conducting Force Controlled Constant Amplitude Axial Fatigue Tests of Metallic Materials<sup>2</sup>
- E 467 Practice for Verification of Constant Amplitude Dynamic Loads on Displacements in an Axial Load Fatigue Testing Machine<sup>2</sup>
- E 468 Practice for Presentation of Constant Amplitude Fatigue Test Results for Metallic Materials<sup>2</sup>
- E 739 Practice for Statistical Analysis of Linear or Linearized Stress-Life ( $S-N$ ) or Strain-Life ( $\epsilon-N$ ) Fatigue Data<sup>2</sup>
- E 1012 Practice for Verification of Specimen Alignment Under Tensile Loading<sup>2</sup>
- E 1150 Definitions of Terms Relating to Fatigue<sup>2</sup>
- F 86 Practice for Surface Preparation and Marking of Metallic Surgical Implants<sup>3</sup>

<sup>1</sup> This practice is under the jurisdiction of ASTM Committee F-4 on Medical and Surgical Materials and Devices and is the direct responsibility of Subcommittee F04.15 on Material Test Methods.

Current edition approved April 10, 1997. Published April 1998.

<sup>2</sup> Annual Book of ASTM Standards, Vol 03.01.

<sup>3</sup> Annual Book of ASTM Standards, Vol 13.01.

F 601 Practice for Fluorescent Penetrant Inspection of Metallic Surgical Implants<sup>3</sup>

G 15 Terminology Relating to Corrosion and Corrosion Testing<sup>4</sup>

2.2 ANSI Standard:

ANSI B46.1 Surface Texture<sup>5</sup>

### 3. Terminology

#### 3.1 Definitions:

3.1.1 The terminology used in conjunction with this practice complies to Terminology E 1150 and Terminology G 15.

#### 3.2 Definitions of Terms Specific to This Standard:

3.2.1  $S-N$  curves— $S-N$  curves (also known as Wöhler-curves) show the correlation between the applied stress ( $S$ ) and the counted number ( $N$ ) of cycles to failure.

### 4. Significance and Use

4.1 Implants, particularly orthopedic devices, are usually exposed to dynamic forces. Thus, implant materials must have high fatigue resistance in the physiological environment.

4.1.1 This practice provides a procedure for fatigue testing in a simulated physiological environment. Axial tension-tension fatigue tests in an environmental test chamber are recommended as a standard procedure. The axial fatigue loading shall comply with Practice E 466 and Practice E 467.

4.1.1.1 Bending and rotating bending beam fatigue tests or torsion tests may be performed in a similar environmental cell.

4.1.2 This practice is intended to assess the fatigue and corrosion fatigue properties of materials that are employed or projected to be employed for implants. This practice is suitable for studying the effects of different material treatments and surface conditions on the fatigue behavior of implant materials. The loading mode of the actual implants may be different from that of this practice. Determining the fatigue behavior of implants and implant components may require separate tests that consider the specific design and loading mode.

4.1.3 As a substitute for body fluid, 0.9 % saline solution is recommended as a standard environment. One of the various Ringer's solutions or another substitute for body fluid may also be suitable for particular tests. However, these various solutions may not give equal fatigue endurance results. The

<sup>4</sup> Annual Book of ASTM Standards, Vol 03.02.

<sup>5</sup> Available from American National Standards Institute, 11 W. 42nd St., 13th Floor, New York, NY 10036.

chloride ions are the most critical constituent in these solutions in initiating corrosion fatigue.

4.1.4 Because implants are manufactured from highly corrosion resistant materials, no visible corrosion may be detectable by optical or electron-optical (SEM) means. Only a decrease of fatigue strength in the high cyclic life range may be noticeable. Therefore, S-N curves covering a broad fatigue loading range should be generated in 0.9 % saline solution (Ringer's solutions) and air. Comparison of fatigue curves generated in air and saline solution may be the only way to assess the effect of the saline environment.

4.1.5 Where the fatigue behavior of a material system is already established, it may suffice to test modifications of the material properties or surface condition in only a selected stress range.

4.1.6 The recommended loading frequency of one Hertz corresponds to the frequency of weight-bearing during walking. For screening tests, higher test frequencies may be used; but it must be realized that higher frequencies may affect the results.

4.1.7 *Summary of Standard Conditions*—For inter-laboratory comparisons the following conditions are considered as the standard test. Axial tension-tension tests with cylindrical specimens in 37°C 0.9 % saline solution and air under a loading frequency of 1Hz.

## 5. Testing Equipment

5.1 The mechanics of the testing machine should be analyzed to ensure that the machine is capable of maintaining the desired form and magnitude of loading for the duration of the test (compare Practice E 4).

### 5.2 Axial Fatigue Testing:

5.2.1 Tension-tension fatigue tests may be performed on one of the following types of axial fatigue testing machines:

- 5.2.1.1 Mechanical,
- 5.2.1.2 Electromechanical or magnetically driven, and
- 5.2.1.3 Hydraulic or electrohydraulic.

5.2.2 The machine shall have a load-monitoring system, such as a transducer mounted in series with the specimen. The test loads shall be monitored continuously in the early stage of the test and periodically thereafter, to ensure that the desired load is maintained. The magnitude of the varying loads, measured dynamically as described in Practice E 467 shall be maintained within an accuracy of less than or equal to 2 % of the extreme loads applied during testing.

5.3 *Non Axial Fatigue Testing*—Corrosion fatigue tests under loading conditions different from axial tension-tension may be requested. In such cases established experimental arrangements for bending, rotating bending beam, or torsional testing may replace the axial tension-tension mode. An environmental test chamber is attached to the equipment and the environmental tests are carried out under conditions as described in this standard. Except for the mechanical testing arrangements the conditions of this standard practice apply where possible. Reporting should follow Section 9 and should include all details where the testing deviates from the standard procedure.

### 5.4 Environmental Chamber:

5.4.1 For corrosion fatigue testing, the machine shall be fitted with an environmental test cell surrounding the specimen gauge section as shown in Fig. 1. A heated solution reservoir, a solution pump, and connecting lines for circulating the test solution to the specimen surface are required. The solution should be pumped from the reservoir through the system at a rate that will maintain the temperature at  $37 \pm 1^\circ\text{C}$  in the test cell, but with flow rates low enough to avoid flow-dependent phenomena like erosion-corrosion. The reservoir should have a minimum capacity of 1000 mL per square centimeter of specimen surface exposed to the electrolyte. The reservoir shall be vented to the atmosphere. If the solution volume decreases, the reservoir shall be replenished with distilled water to maintain the saline concentration, or the solution should be exchanged. During long testing periods exchange of the solution is recommended. A typical environmental test cell for axial fatigue testing is shown in Fig. 1.

5.4.2 The test equipment should be manufactured of materials or should be protected in a manner that corrosion is avoided. In particular galvanic corrosion in conjunction with the test specimen and loosening of the specimen grips due to corrosion must be excluded.

## 6. Test Solution

6.1 To prepare the saline solution, dissolve 9 g of reagent-grade sodium chloride in distilled water and make up to 1000 mL. If other typical Ringer's solutions are used, note the solution in the report.

## 7. Test Specimen

### 7.1 Specimen Design:

#### 7.1.1 Axial Fatigue Testing:

7.1.1.1 The design of the axial load fatigue test specimens should comply to Practice E 466 (see Fig. 2, Fig. 3, Fig. 4 and Fig. 5). For the dimensional proportions of flat specimens refer to the drawing in Practice E 468. The ratio of the test section area to end section area will depend on the specimen geometry and should comply to those standards. The test specimens specified in Practice E 466 and Practice E 468 are designed so that fatigue failure should occur in the section with reduced diameter and not at the grip section.

7.1.1.2 For bending tests one may refer to the specimen configuration suggested in Practice E 466.

7.1.1.3 To calculate the load necessary to obtain the required stress, the cross-sectional area of the specimen test-section must be measured accurately. The dimensions should be measured to the nearest 0.03 mm (0.001 in.) for specimens less than 5.00 mm thick (0.197 in.), and to the nearest 0.05 mm (0.002 in.) for specimens more than 5.00 mm thick (0.197 in.). Surfaces intended to be parallel and straight should be carefully aligned.

7.2 *Specimen Dimensions*—Consult Practice E 466 and Practice E 468 for the dimensions of fatigue specimens for axial tension-tension loading (Fig. 2, Fig. 3, Fig. 4, and Fig. 5). If bending specimens corresponding to the example of Practice E 466 are used, observe the suggested dimensions.

### 7.3 Specimen Preparation:

7.3.1 The method of surface preparation and the resulting surface condition of the test specimens are of great importance

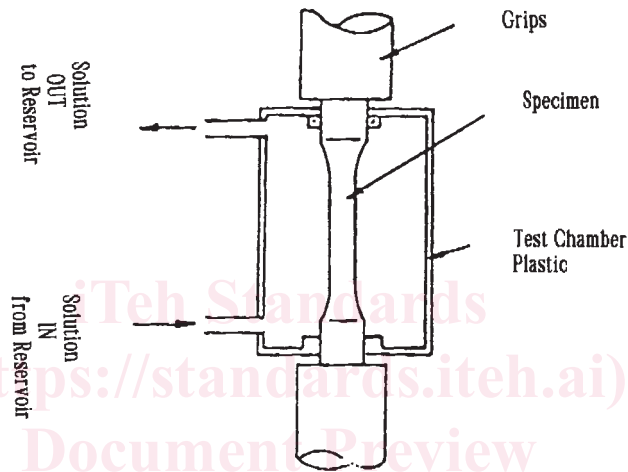
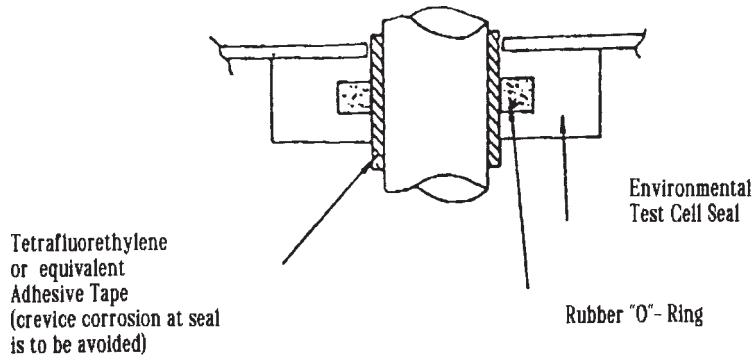

The top of the environmental chamber may be kept open

FIG. 1 Example for Environmental Chamber for Axial Corrosion Fatigue Testing

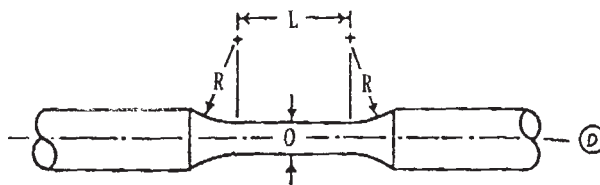

FIG. 2 Specimens With Tangentially Blending Fillets Between the Test Section and the Ends

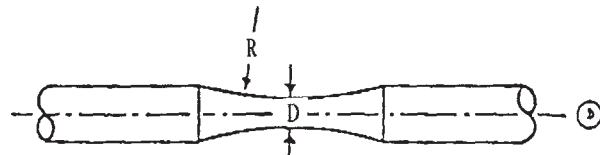

FIG. 3 Specimens With a Continuous Radius Between Ends

because they influence the test results strongly. Standard preparation shall consist of machining, grinding, or polishing, or all of these. A final mechanical polish is suggested to give a finish of 16 Min RA or less in accordance with ANSI B46.1. Alternatively a finish with 600 grit paper in the longitudinal direction may be used. However, specimens that are to be

compared should be prepared the same way. Mechanically finished specimens must then be degreased in acetone, flushed first with ethyl alcohol, then with distilled water, and finally blown dry with warm air.

7.3.1.1 Surface passivation may be carried out where appropriate (compare Practice F 86).