

# INTERNATIONAL STANDARD

ISO  
6841

Second edition  
1988-06-01



---

INTERNATIONAL ORGANIZATION FOR STANDARDIZATION  
ORGANISATION INTERNATIONALE DE NORMALISATION  
МЕЖДУНАРОДНАЯ ОРГАНИЗАЦИЯ ПО СТАНДАРТИЗАЦИИ

---

**Surface active agents — Technical straight-chain  
sodium alkylbenzenesulfonates — Determination of  
mean relative molecular mass by gas-liquid  
chromatography**

**iteh STANDARD PREVIEW**  
**(standards.iteh.ai)**

*Agents de surface — Alkylbenzène sulfonates de sodium linéaires techniques —  
Détermination de la masse moléculaire relative moyenne par chromatographie gaz-liquide*

[ISO 6841:1988](#)

<https://standards.iteh.ai/catalog/standards/sist/f2dd7a43-d81f-42b2-9250-99e78c721266/iso-6841-1988>

Reference number  
ISO 6841 : 1988 (E)

## Foreword

ISO (the International Organization for Standardization) is a worldwide federation of national standards bodies (ISO member bodies). The work of preparing International Standards is normally carried out through ISO technical committees. Each member body interested in a subject for which a technical committee has been established has the right to be represented on that committee. International organizations, governmental and non-governmental, in liaison with ISO, also take part in the work. ISO collaborates closely with the International Electrotechnical Commission (IEC) on all matters of electrotechnical standardization.

Draft International Standards adopted by the technical committees are circulated to the member bodies for approval before their acceptance as International Standards by the ISO Council. They are approved in accordance with ISO procedures requiring at least 75 % approval by the member bodies voting.

International Standard ISO 6841 was prepared by Technical Committee ISO/TC 91, *Surface active agents*.

[ISO 6841:1988](https://standards.iteh.ai/catalog/standards/sist/f2dd7a43-d81f-42b2-9250-5811c1601383)

<https://standards.iteh.ai/catalog/standards/sist/f2dd7a43-d81f-42b2-9250-5811c1601383>

This second edition cancels and replaces the first edition (ISO 6841:1983), of which it constitutes a minor revision.

## Introduction

When using the two-phase titration for the determination of anionic active matter content, it is necessary to know the mean relative molecular mass of the substance.

An accurate and rapid method consists of determining by gas-liquid chromatography (GLC) the mean relative molecular mass of the alkylbenzene used to manufacture the monosulfonated products; the relative molecular mass of the respective monosulfonate or monosulfonic acid can then be calculated by adding the relative molecular mass of the  $\text{SO}_3\text{Na}$  group minus Na, or that of the  $\text{SO}_3\text{H}$  group minus H.

The GLC technique is only applicable to straight-chain alkylbenzenes, since branched-chain types will give chromatograms from which it is impossible to identify and to calculate the relative molecular mass for individual chains.

(NOTE — Any ortho-fused polycyclic hydrocarbon derivatives of low relative molecular mass present, such as indan, and tetrahydronaphthalene, as well as branched-chain alkylbenzenes, are not taken into account in the calculation of the relative molecular mass of the technical straight-chain sodium alkylbenzenesulfonate analysed.)

<https://standards.iteh.ai/catalog/standards/sist/f2dd7a43-d81f-42b2-9250-99e78c721266/iso-6841-1988>

**iTeh STANDARD PREVIEW**  
**(standards.iteh.ai)**

This page intentionally left blank

[ISO 6841:1988](#)

<https://standards.iteh.ai/catalog/standards/sist/f2dd7a43-d81f-42b2-9250-99e78c721266/iso-6841-1988>

# Surface active agents — Technical straight-chain sodium alkylbenzenesulfonates — Determination of mean relative molecular mass by gas-liquid chromatography

## 1 Scope

This International Standard specifies a gas-liquid chromatography (GLC) method for the determination of the mean relative molecular mass of technical straight-chain sodium alkylbenzenesulfonates.

## 2 Normative reference

The following standard contains provisions which, through reference in this text, constitute provisions of this International Standard. At the time of publication, the edition indicated was valid. All standards are subject to revision, and parties to agreements based on this International Standard are encouraged to investigate the possibility of applying the most recent edition of the standard listed below. Members of IEC and ISO maintain registers of currently valid International Standards.

ISO 607: 1980, *Surface active agents and detergents — Methods of sample division.*

## 3 Principle

Desulfonation of a test portion in concentrated phosphoric acid medium and extraction of the liberated alkylbenzene with light petroleum.

Determination of the mean relative molecular mass of the extracted alkylbenzene by GLC.

Calculation of the mean relative molecular mass of the alkylbenzenesulfonate.

## 4 Reagents and materials

During the analysis, use only reagents of recognized analytical grade and only distilled water or water of equivalent purity.

**4.1 Phosphoric acid**, solution, 85 % (*m/m*).

**4.2 Light petroleum**, free from aromatic compounds, distilling between 40 and 60 °C.

**4.3 Sodium sulfate**, anhydrous.

**4.4 Sodium hydroxide**, 160 g/l solution.

**4.5 Reference alkylbenzene**: mixture of alkylbenzenes of known chain lengths, for example from C<sub>15</sub> to C<sub>21</sub> (phenyl group included).

A product of known composition can be adopted as reference sample. This reference sample cannot be used for identification purposes but only for checking the proper performance of the chromatograph.

**4.6 Carrier gas**: nitrogen, helium, argon or hydrogen.

**4.7 Acetone** (if necessary).

## 5 Apparatus

Usual laboratory equipment, and

**5.1 Combustion tube**, one end closed, of diameter 12 mm and length 120 mm. (Ready-made tubes are available on the market.)

**5.2 Test tubes**, of similar dimensions to the combustion tube (5.1), fitted with a ground glass stopper.

**5.3 Metallic safety tube**, capable of accommodating the sealed combustion tube (5.1). It contains a cushioning disc (see the note) to prevent breakage of the combustion tube and is fitted with a screw cap (see figure 1).

NOTE — To obtain the best cushioning effect, the disc should preferably be made of silicone rubber and polytetrafluoroethylene, although silicone rubber discs, of thickness 3 mm, are suitable. The use of polytetrafluoroethylene discs is not advised.

**5.4 Heating device**: capable of being controlled at a temperature of about 250 °C, for example a silicone oil bath.

**5.5 Chromatograph**, with the following elements:

**5.5.1 Capillary column**, of length 20 to 50 m, in spiral form, of internal diameter 0,25 mm and external diameter 1,1 mm, coated with an apolar stationary phase for high temperatures (for example, a dimethylsiloxane type, such as silicone OV 101), preconditioned at the test temperature; or a **packed column**, of length 1 to 6 m, provided that the chromatogram peaks are sufficiently well separated.

5.5.2 Flame ionization detector.

5.5.3 Electronic integrator.

5.5.4 Recorder.

5.6 Syringe, of capacity 5 or 10  $\mu$ l.

5.7 Pasteur pipette.

## 6 Sampling

The laboratory sample of surface active agent shall be prepared and stored in accordance with the instructions given in ISO 607.

## 7 Procedure

### 7.1 Test portion

Weigh, to the nearest 1 mg, into the combustion tube (5.1), 50 to 100 mg of the laboratory sample.

### 7.2 Desulfonation

Add 2 ml of the phosphoric acid solution (4.1) to the combustion tube containing the test portion and seal the tube carefully using an oxygen/gas or oxygen/air flame.

NOTE — The combustion tube should be thoroughly sealed, with minimal reduction of wall thickness to avoid breakage during desulfonation. This is best done by slowly rotating the tube and heating it using an oxygen/gas or oxygen/air flame. As soon as the glass is sufficiently soft, gentle pressure should be applied to each end of the tube so as to thicken the wall. The ends of the tube are then pulled to obtain a capillary tube and it is finally sealed at point A (see figure 2).

Place the sealed tube in the safety tube (5.3) on the cushioning disc and close the safety tube with its screw cap.

Place the safety tube for approximately 15 min in the heating device (5.4), controlled at approximately 250 °C. Remove the safety tube, cool it in running water and remove the sealed combustion tube.

Open the combustion tube and transfer its contents to one of the test tubes (5.2). Rinse the combustion tube with 2 ml of the light petroleum (4.2) and transfer the washings to the test tube.

Stopper the test tube and shake it. Allow to settle and, using the Pasteur pipette (5.7), transfer the light petroleum layer to a second test tube (5.2).

Add a further 2 ml of the light petroleum (4.2) to the first test tube, stopper it, shake and allow to settle. Transfer, using the Pasteur pipette, the light petroleum layer to the second test tube.

Add 1 ml of the sodium hydroxide solution (4.4) to the combined light petroleum extracts, stopper the test tube, shake it and allow to settle. Using the Pasteur pipette, transfer the light petroleum layer to a third test tube (5.2). Wash the light petroleum extract three times more with 1 ml portions of the sodium hydroxide solution, rejecting the aqueous layer after each washing.

Add approximately 1 g of the anhydrous sodium sulfate (4.3) to the light petroleum extract, stopper the test tube and shake.

Transfer the light petroleum extract to another of the test tubes (5.2) and evaporate off most of the light petroleum by gently heating in a water bath controlled at 60 to 70 °C.

### 7.3 Chromatographic analysis

The following conditions are given as examples and have been found to be suitable.

#### 7.3.1 Chromatograph settings

##### 7.3.1.1 Injection

Temperature greater than 210 °C.

##### 7.3.1.2 Column

a) Isothermal conditions

Temperature between 170 and 200 °C according to the nature of the sample.

b) Programmed conditions

Initial temperature between 140 and 170 °C, raised at a rate of 0,5 to 2 °C/min to the final temperature between 180 and 210 °C.

##### 7.3.1.3 Carrier gas

Flow rate between 0,3 and 40 ml/min according to the type and diameter of the column.

##### 7.3.1.4 Detector conditions

Temperature greater than 210 °C.

#### 7.3.2 Instrument performance check

Inject into the chromatograph sufficient of the reference alkylbenzene (4.5) to give a chromatogram which exhibits all the anticipated peaks. Note the retention times and the separations obtained (for future comparison with the sample).

#### 7.3.3 Test

##### 7.3.3.1 Preparation of the test portion

If the capillary column (5.5.1) is used, prepare a mixture of 1 volume of the alkylbenzene extract (7.2) and 1 volume of acetone (4.7). If the packed column (5.5.1) is used, the alkylbenzene extract shall, if possible, be used directly, or otherwise diluted with the acetone up to 1 + 1.

### 7.3.3.2 Introduction of the test portion

By means of the syringe (5.6), inject into the chromatograph sufficient of the solution (7.3.3.1) to obtain a suitable chromatogram.

Two typical chromatograms are shown in figure 3.

## 8 Examination of chromatograms

### 8.1 Qualitative analysis

Identify the components of the test portion by comparing the test chromatogram with that for the reference alkylbenzene (4.5).

### 8.2 Quantitative analysis

Determine the area of each peak corresponding to a particular chain length (or group of isomers) using the data from the integrator (5.5.3). Calculate the total peak area.

## 9 Expression of results

### 9.1 Method of calculation

The area corresponding to a chain length or group of isomers  $B_i$ , expressed as a percentage of the total peak area, is given by the equation

$$B_i = \frac{a_i \times 100}{A}$$

The mean relative molecular mass of the alkylbenzene is given by the formula

$$\frac{100}{\sum_i \frac{B_i}{M_r}}$$

where

$a_i$  is the area of the peak corresponding to a chain length or group of isomers;

$A$  is the total peak area;

$M_r$  is the relative molecular mass of the isomers, the number of carbon atoms of which includes those in the phenyl group, as follows:

	$M_r$
C <sub>15</sub>	204
C <sub>16</sub>	218
C <sub>17</sub>	232
C <sub>18</sub>	246
C <sub>19</sub>	260
C <sub>20</sub>	274
C <sub>21</sub>	288

Calculate the mean relative molecular mass of the alkylbenzenesulfonate by adding 102 to the calculated relative molecular mass of the alkylbenzene.

### 9.2 Precision

Comparative analyses, on a sample of sodium alkylbenzene sulfonate, carried out in 10 laboratories, have given the following statistical results:

— mean (mean relative molecular mass)	340
— standard deviation of repeatability, $\sigma_r$	4
— standard deviation of reproducibility, $\sigma_R$	4,8

## 10 Test report

The test report shall include the following information:

- all the information necessary for the complete identification of the sample;
- the reference of the method used (reference to this International Standard);
- the results and the method of expression used;
- details of any operation not specified in this International Standard, or any operation regarded as optional, together with details of any incidents likely to have affected the results.

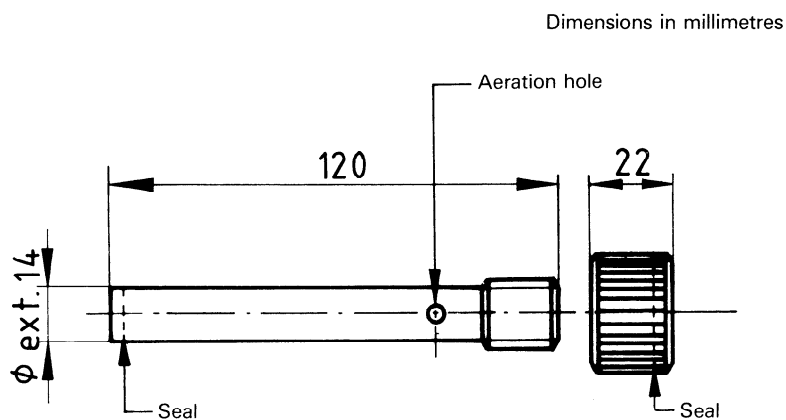

Figure 1 — Safety tube with screw cap

**iTeh STANDARD PREVIEW**  
**(standards.iteh.ai)**

ISO 6841:1988

[https://standards.iteh.ai/catalog/standards/sist/f2dd7a43-d81f-42b2-9250-](https://standards.iteh.ai/catalog/standards/sist/f2dd7a43-d81f-42b2-9250-19c73c722386/iso-6841-1988)

[19c73c722386/iso-6841-1988](https://standards.iteh.ai/catalog/standards/sist/f2dd7a43-d81f-42b2-9250-19c73c722386/iso-6841-1988)

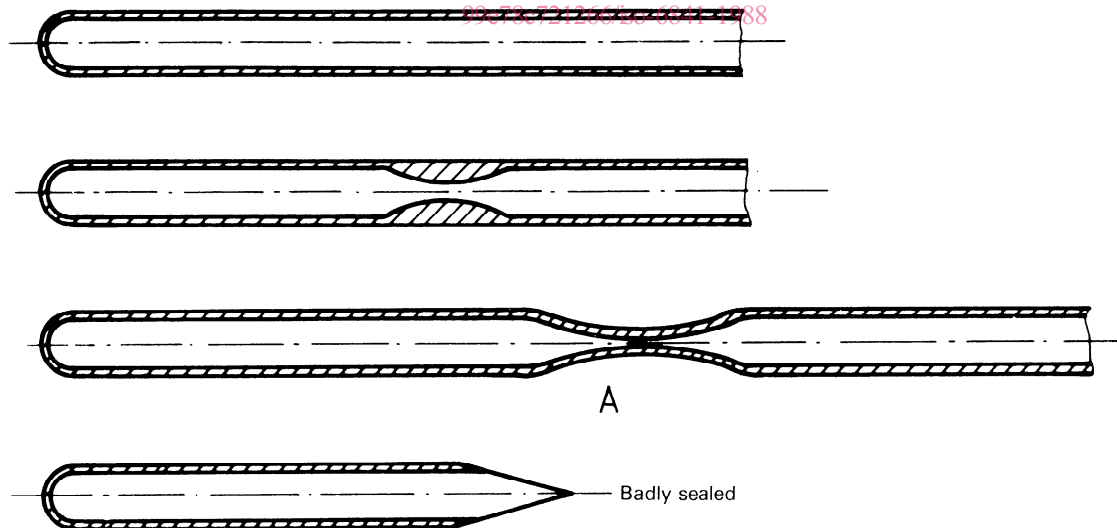

Figure 2 — Sealing the combustion tube



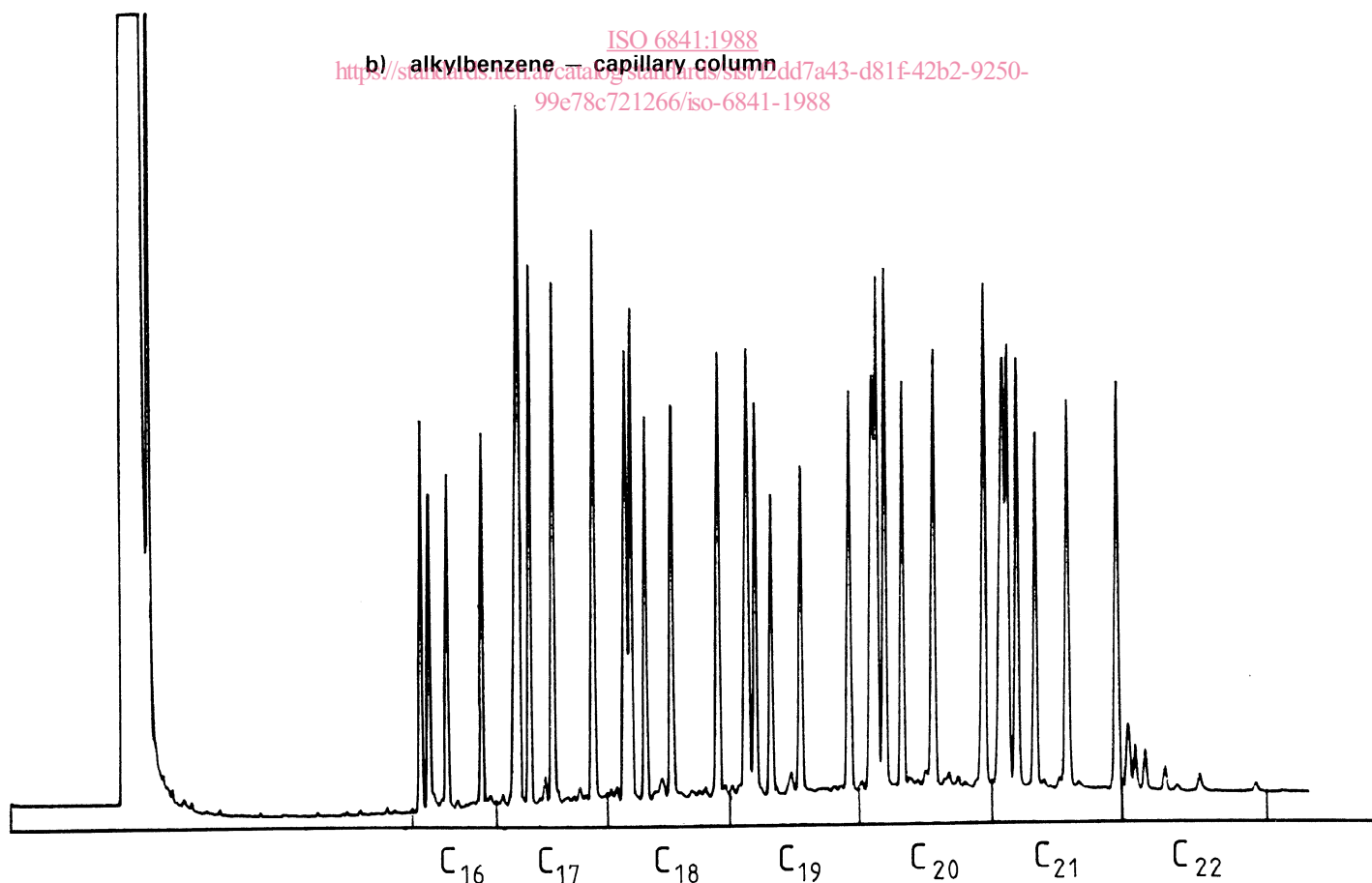
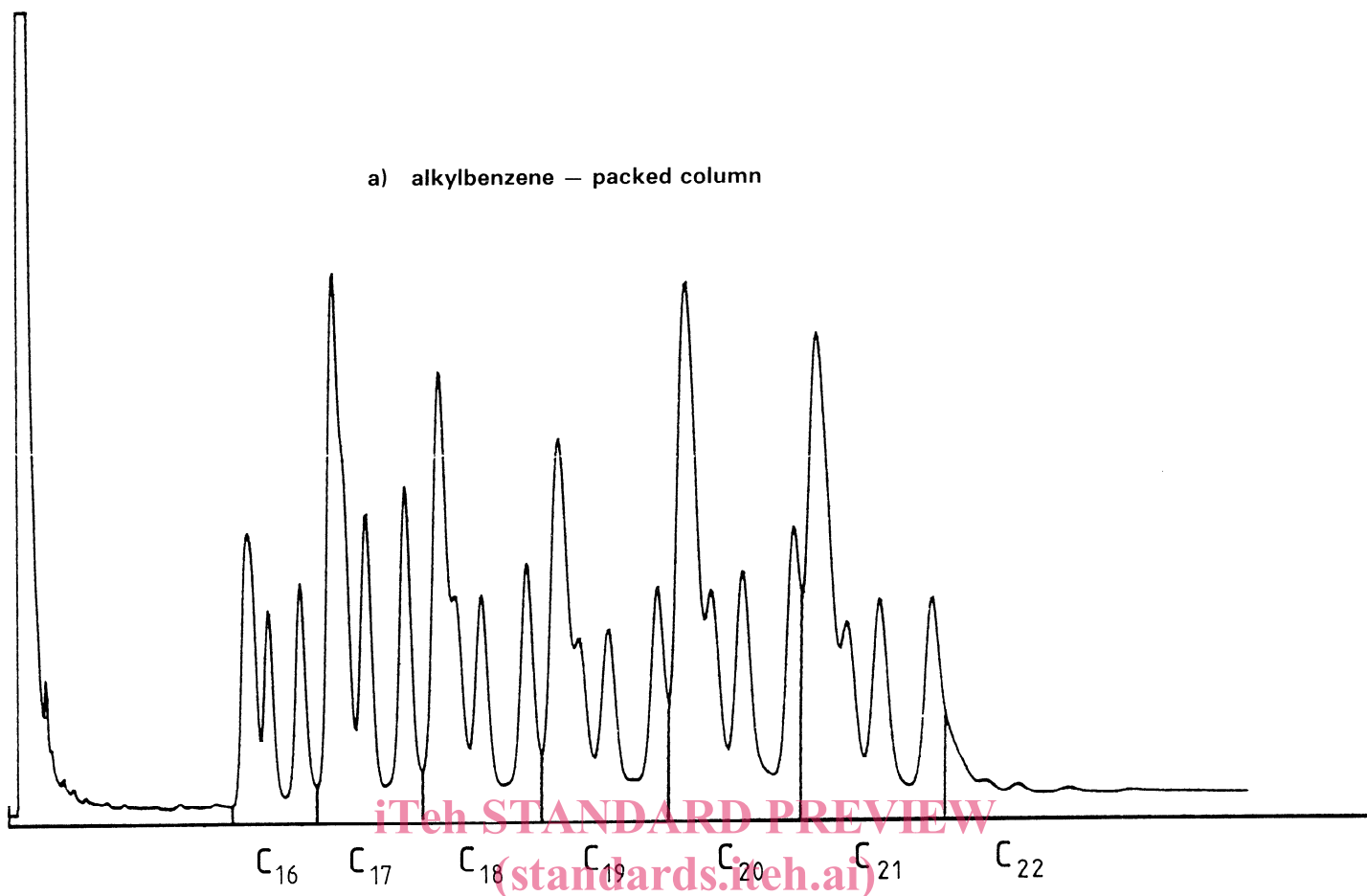

Figure 3 — Typical chromatograms