

INTERNATIONAL STANDARD

**IEC
60205**

Third edition
2006-04

Calculation of the effective parameters of magnetic piece parts

iTech Standards
(<https://standards.iteh.ai>)
Document Preview

[IEC 60205:2006](https://standards.iteh.ai/catalog/standards/iec/60205-2006)

<https://standards.iteh.ai/catalog/standards/iec/60205-2006>



Reference number
IEC 60205:2006(E)

Publication numbering

As from 1 January 1997 all IEC publications are issued with a designation in the 60000 series. For example, IEC 34-1 is now referred to as IEC 60034-1.

Consolidated editions

The IEC is now publishing consolidated versions of its publications. For example, edition numbers 1.0, 1.1 and 1.2 refer, respectively, to the base publication, the base publication incorporating amendment 1 and the base publication incorporating amendments 1 and 2.

Further information on IEC publications

The technical content of IEC publications is kept under constant review by the IEC, thus ensuring that the content reflects current technology. Information relating to this publication, including its validity, is available in the IEC Catalogue of publications (see below) in addition to new editions, amendments and corrigenda. Information on the subjects under consideration and work in progress undertaken by the technical committee which has prepared this publication, as well as the list of publications issued, is also available from the following:

- **IEC Web Site** (www.iec.ch)

- **Catalogue of IEC publications**

The on-line catalogue on the IEC web site (www.iec.ch/searchpub) enables you to search by a variety of criteria including text searches, technical committees and date of publication. On-line information is also available on recently issued publications, withdrawn and replaced publications, as well as corrigenda.

- **IEC Just Published**

This summary of recently issued publications (www.iec.ch/online_news/justpub) is also available by email. Please contact the Customer Service Centre (see below) for further information.

- **Customer Service Centre**

If you have any questions regarding this publication or need further assistance, please contact the Customer Service Centre:

Email: custserv@iec.ch
Tel: +41 22 919 02 11
Fax: +41 22 919 03 00

<https://standards.iteh.ai/catalog/standards/iec/60034-1-487b-b1f9-78d7485369c9/iec-60205-2006>

INTERNATIONAL STANDARD

IEC 60205

Third edition
2006-04

Calculation of the effective parameters of magnetic piece parts

iTech Standards
(<https://standards.itih.ai>)
Document Preview

<https://standards.itih.ai/collections/standards/iec/60205-2006>

<https://standards.itih.ai/collections/standards/iec/60205-2006>

© IEC 2006 — Copyright - all rights reserved

No part of this publication may be reproduced or utilized in any form or by any means, electronic or mechanical, including photocopying and microfilm, without permission in writing from the publisher.

International Electrotechnical Commission, 3, rue de Varembe, PO Box 131, CH-1211 Geneva 20, Switzerland
Telephone: +41 22 919 02 11 Telefax: +41 22 919 03 00 E-mail: inmail@iec.ch Web: www.iec.ch



Commission Electrotechnique Internationale
International Electrotechnical Commission
Международная Электротехническая Комиссия

PRICE CODE

U

For price, see current catalogue

CONTENTS

FOREWORD.....	3
1 Scope.....	5
2 Basic rules.....	5
3 Formulae for the various types of cores.....	6
3.1 Ring cores.....	6
3.2 Pair of U-cores of rectangular section.....	7
3.3 Pair of U-cores of rounded section.....	7
3.4 Pair of E-cores of rectangular section.....	9
3.5 Pair of ETD/EER-cores.....	10
3.6 Pair of pot-cores.....	11
3.7 Pair of RM-cores.....	13
3.8 Pair of EP-cores.....	16
3.9 Pair of PM-cores.....	17
3.10 Pair of EL-cores.....	19
3.11 Pair of ER-cores (low profile).....	21
3.12 Pair of PQ-cores.....	23
3.13 Pair of EFD-cores.....	25
3.14 Pair of E planar-cores.....	26
Annex A (informative) Purpose of revision.....	29

ITeK Standards
(<https://standards.iteh.ai>)
Document Preview

IEC 60205:2006

<https://standards.iteh.ai/catalog/standards/iec/b97d3cd-2521-487b-b1f9-78d7485369c9/iec-60205-2006>

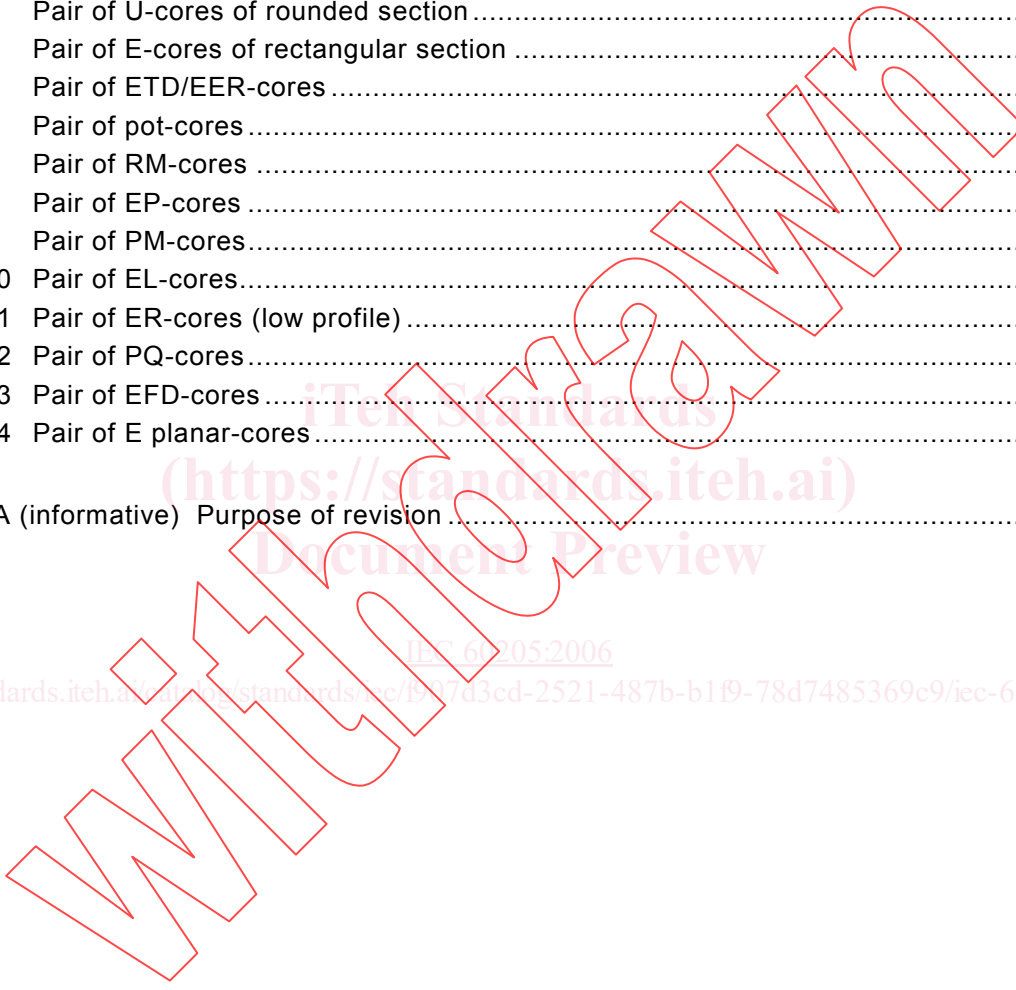

INTERNATIONAL ELECTROTECHNICAL COMMISSION

CALCULATION OF THE EFFECTIVE PARAMETERS OF MAGNETIC PIECE PARTS

FOREWORD

- 1) The International Electrotechnical Commission (IEC) is a worldwide organization for standardization comprising all national electrotechnical committees (IEC National Committees). The object of the IEC is to promote international co-operation on all questions concerning standardization in the electrical and electronic fields. To this end and in addition to other activities, IEC publishes International Standards, Technical Specifications, Technical Reports, Publicly Available Specifications (PAS) and Guides (hereafter referred to as "IEC Publication(s)"). Their preparation is entrusted to technical committees; any IEC National Committee interested in the subject dealt with may participate in this preparatory work. International, governmental and non-governmental organizations liaising with the IEC also participate in this preparation. IEC collaborates closely with the International Organization for Standardization (ISO) in accordance with conditions determined by agreement between the two organizations.
- 2) The formal decisions or agreements of IEC on technical matters express, as nearly as possible, an international consensus of opinion on the relevant subjects since each technical committee has representation from all interested IEC National Committees.
- 3) IEC Publications have the form of recommendations for international use and are accepted by IEC National Committees in that sense. While all reasonable efforts are made to ensure that the technical content of IEC Publications is accurate, IEC cannot be held responsible for the way in which they are used or for any misinterpretation by any end user.
- 4) In order to promote international uniformity, IEC National Committees undertake to apply IEC Publications transparently to the maximum extent possible in their national and regional publications. Any divergence between any IEC Publication and the corresponding national or regional publication shall be clearly indicated in the latter.
- 5) IEC provides no marking procedure to indicate its approval and cannot be rendered responsible for any equipment declared to be in conformity with an IEC Publication.
- 6) All users should ensure that they have the latest edition of this publication.
- 7) No liability shall attach to IEC or its directors, employees, servants or agents including individual experts and members of its technical committees and IEC National Committees for any personal injury, property damage or other damage of any nature whatsoever, whether direct or indirect, or for costs (including legal fees) and expenses arising out of the publication, use of, or reliance upon, this IEC Publication or any other IEC Publications.
- 8) Attention is drawn to the Normative references cited in this publication. Use of the referenced publications is indispensable for the correct application of this publication.
- 9) Attention is drawn to the possibility that some of the elements of this IEC Publication may be the subject of patent rights. IEC shall not be held responsible for identifying any or all such patent rights.

International Standard IEC 60205 has been prepared by IEC technical committee 51: Magnetic components and ferrite materials.

This third edition cancels and replaces the second edition published in 2001, corrigendum 1 (2001). This edition constitutes a technical revision.

This edition includes the following significant technical changes with respect to the previous edition:

- a) unit of angles through the text are described by using "radian";
- b) new words are added in 2.1 "All angles are in radians";
- c) replacement, Clause 3.9, of the equation $\frac{l_2}{A_2} = \frac{\ln d_2 g / d_3}{D\pi(h_1 - h_2)}$ by $\frac{l_2}{A_2} = \frac{\ln d_2 g / d_3}{D\pi(h_1 - h_2)/2}$;
- d) new cores "EL, ER, PQ, EFD and E planar" are added in this edition.

The text of this standard is based on the following documents:

FDIS	Report on voting
51/848/FDIS	51/857/RVD

Full information on the voting for the approval of this standard can be found in the report on voting indicated in the above table.

This publication has been drafted in accordance with the ISO/IEC Directives, Part 2.

The committee has decided that the contents of this publication will remain unchanged until the maintenance result date indicated on the IEC web site under "<http://webstore.iec.ch>" in the data related to the specific publication. At this date, the publication will be

- reconfirmed;
- withdrawn;
- replaced by a revised edition, or
- amended.

A bilingual version of this publication may be issued at a later date.

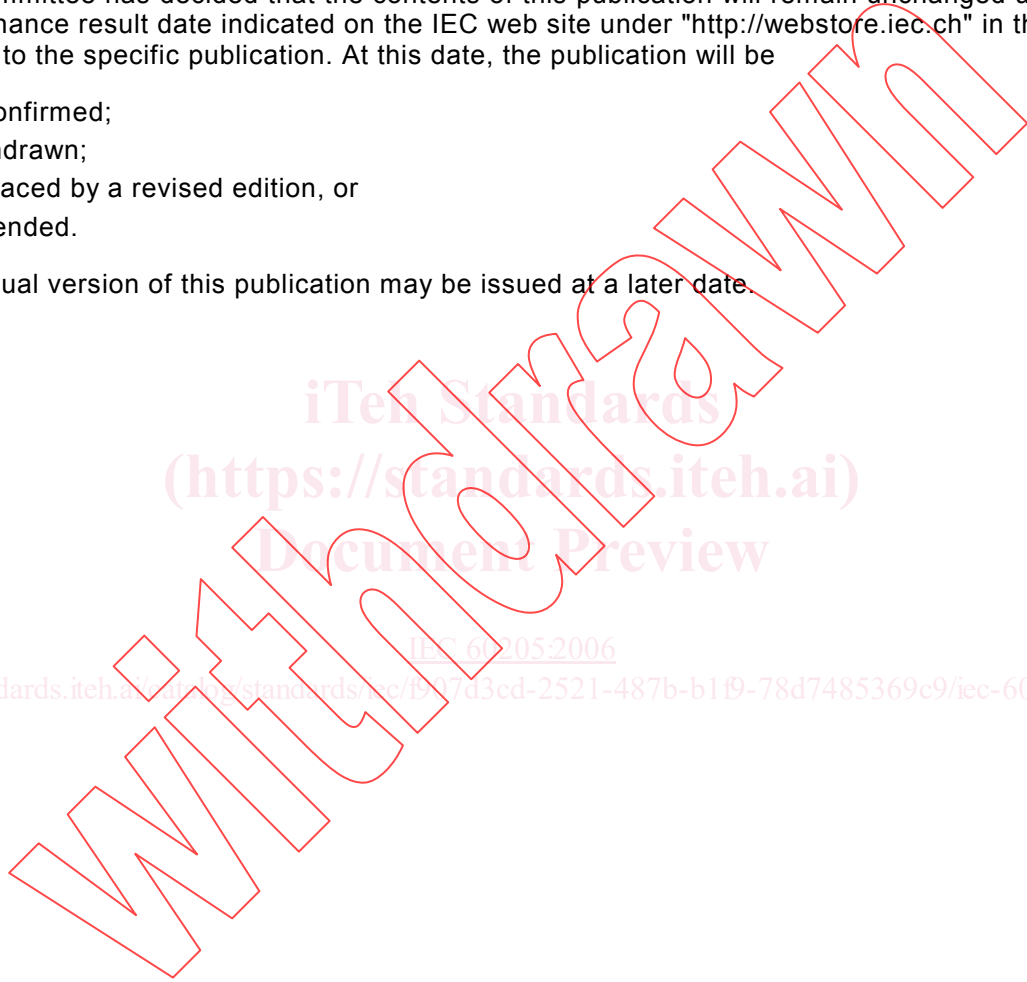

iTech Standards
(<https://standards.itih.ai>)
Document Preview

[IEC 60205:2006](#)

<https://standards.itih.ai/cats/standards/iec/f97d3cd-2521-487b-b1f9-78d7485369c9/iec-60205-2006>

CALCULATION OF THE EFFECTIVE PARAMETERS OF MAGNETIC PIECE PARTS

1 Scope

This International Standard lays down uniform rules for the calculation of the effective parameters of closed circuits of ferromagnetic material.

2 Basic rules

The following basic rules are applicable to this standard.

2.1 All results shall be expressed in units based on the millimetre, shall be accurate to three significant figures, but to derive l_e , A_e , and V_e the values of C_1 and C_2 shall be calculated to five significant figures. All angles are in radians.

NOTE The purpose of specifying this degree of accuracy is only to ensure that parameters calculated at different establishments are identical and it is not intended to imply that the parameters are capable of being determined to this accuracy.

2.2 A_{\min} is the nominal value of the smallest cross-section. All the dimensions used to calculate A_{\min} shall be the mean values between the tolerance limits quoted on the appropriate piece part drawing.

2.3 Calculations are only applicable to the component parts of a closed magnetic circuit.

2.4 All dimensions used for the purpose of calculations shall be the mean value within the tolerance limits quoted on the appropriate piece part drawing.

2.5 All irregularities in the outline of the core, such as small cut-outs, notches, chamfers, etc. shall be ignored unless otherwise described.

2.6 When the calculation involves the sharp corner of a piece part, then the mean length of flux path for that corner shall be taken as the mean circular path joining the centres of area of the two adjacent uniform sections, and the cross-sectional area associated with that length shall be taken as the average area of the two adjacent uniform sections.

Calculation of effective parameters l_e , A_e and V_e .

The effective parameters can be defined as

$$l_e = C_1^2 / C_2 \quad A_e = C_1 / C_2 \quad V_e = l_e A_e = C_1^3 / C_2^2$$

where

l_e is the effective magnetic length of the core (mm);

A_e is the effective cross-sectional area (mm²);

V_e is the effective volume (mm³);

C_1 is the core constant (mm⁻¹);

C_2 is the core constant (mm⁻³).

3 Formulae for the various types of cores

3.1 Ring cores

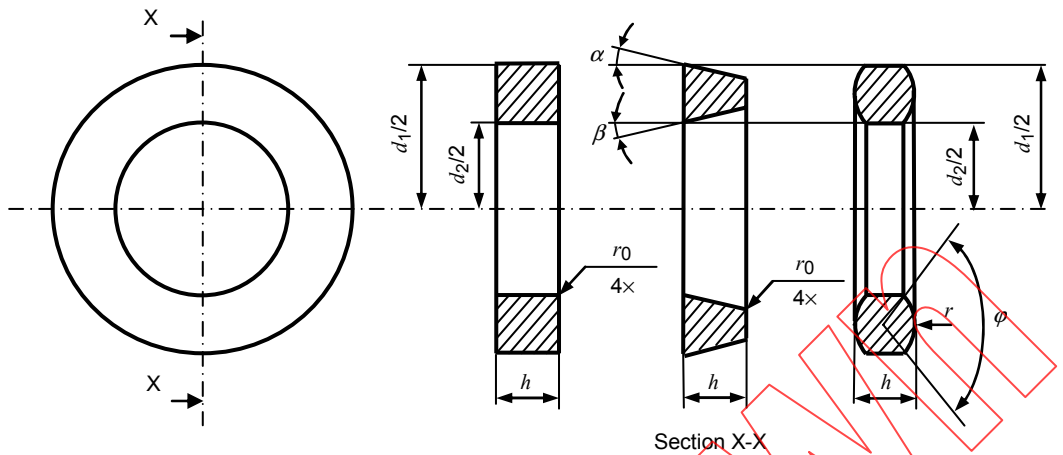

IEC 584/06

$$C_1 = \frac{2\pi}{h_e \ln(d_1/d_2)}$$

$$C_2 = \frac{4\pi(1/d_2 - 1/d_1)}{h_e^2 \ln^3(d_1/d_2)}$$

3.1.1 For ring cores of rectangular cross-section with sharp corners

$$h_e = h$$

3.1.2 For ring cores of rectangular cross-section with an appreciable average rounding radius r_0

$$h_e = h(1 - k_1) \quad k_1 = \frac{1,7168r_0^2}{h(d_1 - d_2)}$$

3.1.3 For ring cores of trapezoidal cross-section with sharp corners

$$h_e = h(1 - k_2) \quad k_2 = \frac{h(\tan \alpha + \tan \beta)}{d_1 - d_2}$$

3.1.4 For ring cores of trapezoidal cross-section with an appreciable average rounding radius r_0

$$h_e = (1 - k_1 - k_2)h$$

3.1.5 For ring cores of cross-section with circular arc frontal sides

$$h_e = h - \frac{d_1 - d_2}{4\sin^2(\varphi/2)} \left(2\sin \frac{\varphi}{2} - \frac{\sin \varphi}{2} - \frac{\varphi}{2} \right)$$

$$\varphi = 2 \arcsin \frac{d_1 - d_2}{4r}$$

NOTE When the winding is uniformly distributed over a ring core, it may be expected that, at all points inside the ring core, the flux lines will be parallel to its surface.

No leakage flux will therefore leave or enter the ring core. This justifies the use of a theoretically more correct derivation of the effective parameters which does not make use of the assumption that the flux is uniformly distributed over the cross-section.

3.2 Pair of U-cores of rectangular section

NOTE U + PLT (Plate)-cores use U core formulas

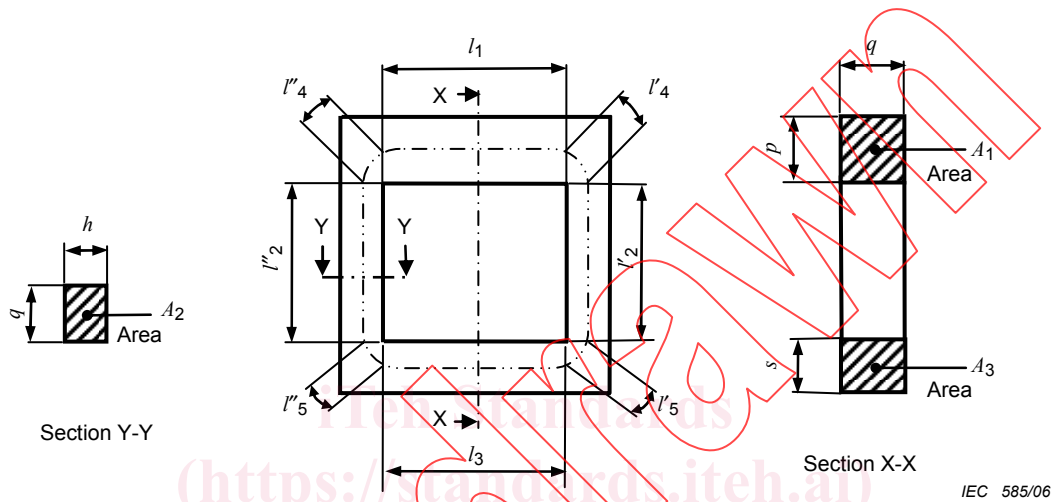

IEC 585/06

Length of flux path associated with area A_2 :

$$l_2 = l'_2 + l''_2$$

Mean length of flux paths at corners:

$$l_4 = l'_4 + l''_4 = \frac{\pi}{4}(p + h)$$

$$l_5 = l'_5 + l''_5 = \frac{\pi}{4}(s + h)$$

Mean areas associated with l_4 and l_5 :

$$A_4 = \frac{A_1 + A_2}{2}$$

$$A_5 = \frac{A_2 + A_3}{2}$$

$$C_1 = \sum_{i=1}^5 \frac{l_i}{A_i} \quad C_2 = \sum_{i=1}^5 \frac{l_i}{A_i^2}$$

3.3 Pair of U-cores of rounded section

NOTE U + PLT (Plate)-cores use U core formulas.

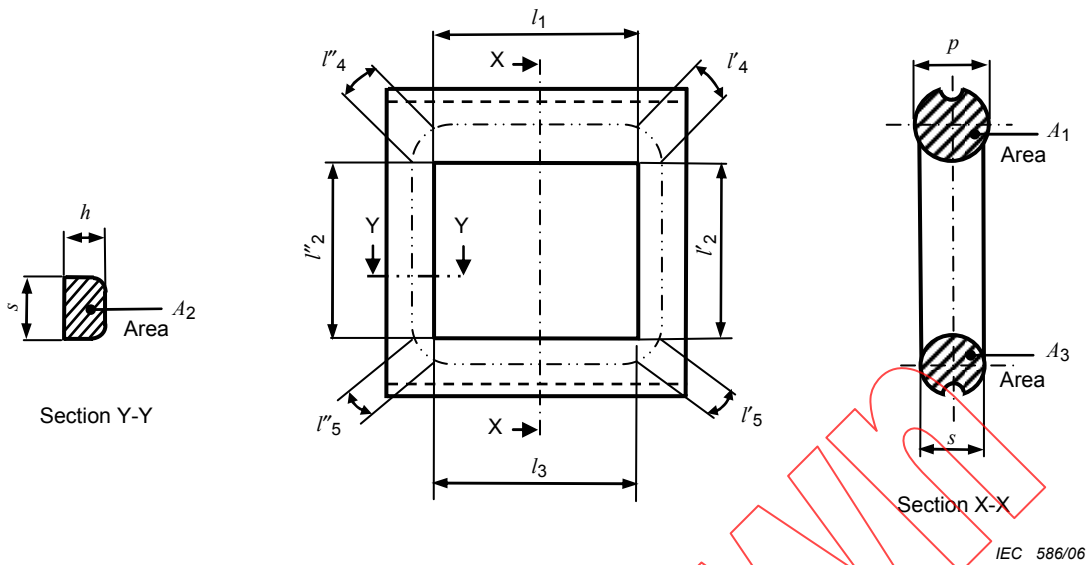

In calculating A_2 ignore any ridges introduced for the purpose of facilitating manufacture.

Length of flux path associated with area A_2 :

$$l_2 = l'_2 + l''_2$$

Mean length of flux path at corners:

$$l_4 = l'_4 + l''_4 = \frac{\pi}{4}(p + h)$$

$$l_5 = l'_5 + l''_5 = \frac{\pi}{4}(s + h)$$

Mean areas associated with l_4 and l_5 :

$$A_4 = \frac{A_1 + A_2}{2}$$

$$A_5 = \frac{A_2 + A_3}{2}$$

$$C_1 = \sum_{i=1}^5 \frac{l_i}{A_i} \quad C_2 = \sum_{i=1}^5 \frac{l_i}{A_i^2}$$

3.4 Pair of E-cores of rectangular section

NOTE E + I (Plate)-cores use E core formulas.

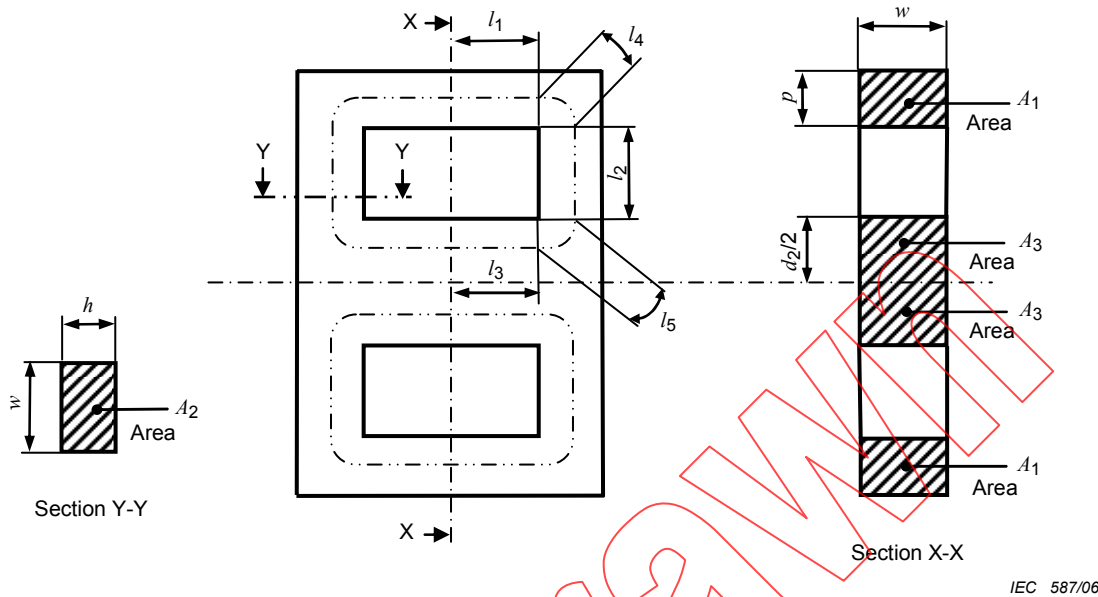

Area of half the centre limb: A_3

Mean length of flux paths at corners:

$$l_4 = \frac{\pi}{8}(p+h)$$

$$l_5 = \frac{\pi}{8}\left(\frac{d_2}{2} + h\right)$$

Mean areas associated with l_4 and l_5 :

$$A_4 = \frac{A_1 + A_2}{2}$$

$$A_5 = \frac{A_2 + A_3}{2}$$

$$C_1 = \sum_{i=1}^5 \frac{l_i}{A_i} \quad C_2 = \sum_{i=1}^5 \frac{l_i}{2A_i^2}$$