



Standard Test Method for Measuring Sleeping Bag Packing Volume¹

This standard is issued under the fixed designation F 1853; the number immediately following the designation indicates the year of original adoption or, in the case of revision, the year of last revision. A number in parentheses indicates the year of last reapproval. A superscript epsilon (ϵ) indicates an editorial change since the last revision or reapproval.

1. Scope

1.1 This test method covers the quantitative volume of a sleeping bag in a cylinder under a standardized load.

1.2 This test method uses a physical volumetric measurement applicable in the laboratory or in the field.

1.3 The values stated in SI units are to be regarded as standard. The inch-pound units given in parentheses are provided for information only.

1.4 *This standard does not purport to address all of the safety concerns, if any, associated with its use. It is the responsibility of the user of this standard to establish appropriate safety and health practices and determine the applicability of regulatory limitations prior to use.*

2. Terminology

2.1 Definitions:

2.1.1 *sleeping bag, n*—a structure made of down, synthetic fiberfill, shell fabrics, or other materials, or both, that is designed for people to use for thermal protection when sleeping (for example, outdoors, tent, cabin).

3. Significance and Use

3.1 This test method can be used to quantify and compare packing volumes of sleeping bags. It defines the volume occupied by a sleeping bag under a standardized load (see 4.2).

4. Apparatus

4.1 *Measuring Cylinder*—A circularly round container, measuring in diameter 45 ± 3 cm (18 ± 1 in.), suitable to contain the sleeping bag being measured, and capable of not deforming when the loading system is applied. See Annex A1 for specifications on a typical design.

4.2 *Loading System*—A circular plate or piston structure that closely matches the diameter of the measuring cylinder, with weights, that provides a 3.45 ± 0.07 kPa (0.50 ± 0.01 psi) load. The diameter of the plate or piston structure should be slightly undersized, compared to the measuring cylinder, to allow air to escape as the bag under test is subject to the

loading force. Small ventilation holes are also acceptable to allow air to escape. See Annex A1 for specifications on a typical design.

4.3 *Measuring Scale*—A scale accurate to 1 mm (1/16 in.) and having a capacity to measure the height of the loading system in the measuring cylinder. For convenience, multiple scales can be placed around (and can be affixed to) the measuring cylinder so opposing height readings can be taken directly. Additionally, scale markings can be customized to read packing volume directly since the cross-sectional area of the cylinder is constant.

5. Procedure

5.1 Perform tests at ambient temperatures between 10 and 25°C (55 and 80°F).

5.2 Zip up the sleeping bag and place feet end first into the measuring cylinder. The bag should be packed down slightly to make its distribution in the measuring cylinder as uniform as possible. Sleeping bags with low air permeability outer shells may be turned inside out to minimize the settling time (entrained air release) when the load is applied.

5.3 Apply the loading system to the sleeping bag in the measuring cylinder and allow to settle. The system is deemed settled when the change in measured height is less than 1 mm in a 1 min interval.

5.3.1 Using the typical design shown in Annex A1, place the 6.12 kg (13.5 lb) piston assembly into the measuring cylinder with the first round disk contacting the surface of the bag. Stack five 9.07 kg (20 lb) weights and one 4.54 kg (10 lb) weight on top of the second disk of the piston assembly for a total of 56.02 kg (123.5 lb).

5.4 Take two height readings to the nearest 1 mm (1/16 in.), one opposite the other, of the height of the compressed bag in the measuring cylinder.

5.4.1 Using the typical design shown in the annex, take two height readings, one opposite the other, at the top of the second disk of the piston assembly. Areas where the bag material creeps up past the loading system or where an air pocket forms should not be used for the measurement. A flashlight can be held inside the semi-transparent measuring cylinder so that the location of the top disk can be accurately determined. Subtract the distance between the top disk and bottom disk (in contact with the bag) from the measurement and use as the bag height

¹ This test method is under the jurisdiction of ASTM Committee F-8 on Sports Equipment and Facilities and is the direct responsibility of Subcommittee F08.22 on Sleeping Bags.

Current edition approved Feb. 10, 1998. Published September 1998.

reading. In accordance with the piston assembly shown in Annex A1, this dimension is 10.2 cm (4 in.).

5.5 *Replication of Tests*—Repeat the procedure above on each bag, where the subject bag is completely removed and shaken for ~1 min and then repacked in the measuring cylinder for each repetition. Average the four resulting height values to yield the sleeping bag height measurement under load.

6. Calculation

6.1 Calculate the packing volume of the sleeping bag under test using the following formula:

$$V = h(\pi r^2) \quad (1)$$

where:

- V = packing volume, m^3 or L, where $1000 \text{ L} = 1 \text{ m}^3$,
 h = height of the sleeping bag under load in the measuring cylinder, m, and
 r = radius of the measuring cylinder, m.

7. Report

7.1 State that the sleeping bag was tested as directed in this test method (ASTM F 1853). Explain any departures from the specified apparatus or procedure.

7.2 Describe the sleeping bag that was tested and its orientation as tested (normal or turned inside out, see 5.2).

7.3 Report the packing volume (V) in m^3 or L, where $1000 \text{ L} = 1 \text{ m}^3$ units. Report packing volume values to three significant figures.

8. Precision and Bias

8.1 *Precision*—The repeatability standard deviation has been determined to be $\pm 6\%$ in one laboratory. The reproducibility of this test method is being determined.

8.2 *Bias*—No information can be presented on the bias of the procedure for determining the packing volume because no sleeping bag having an accepted reference value is available.

9. Keywords

9.1 packing volume; sleeping bag

ANNEX

(Mandatory Information)

A1. DETAILED DESCRIPTION OF APPARATUS

A1.1 A typical packing volume measuring cylinder can be a high density polyethylene (HDPE) seamless, rotation-molded tank with rigid walls, ~46 cm (18 in.) diameter, ~76 cm (30 in.) height, and ~0.5 cm (3/16 in.) wall thickness.

A1.2 A typical loading system in inch-pound units is shown for illustration purposes in Fig. A1.1. The component parts

(also in inch-pound units) are illustrated in Figs. A1.1-A1.5. These are typical examples for construction consideration that meet the dimensional criteria described in Section 4. Weights with a slot width of ~2 cm (3/4 in.) and meeting the National Institute of Standards and Technology Class F tolerances and NIST traceability are preferred.

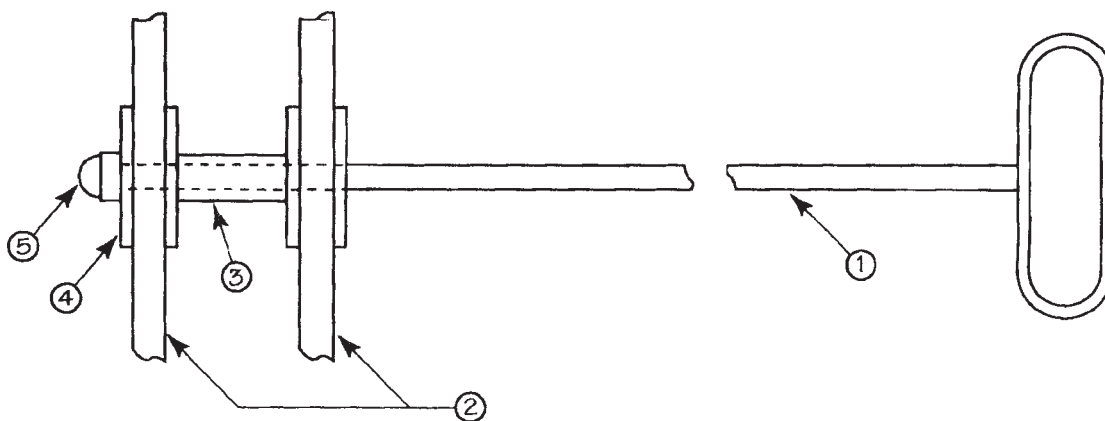

- ① Handle, Part T-4 ③ Spacer, Part T-1 ⑤ Acorn Nut, 1/2-13, Commercial
② Plexiglas Discs, Part T-3 ④ Washer, Part T-2

FIG. A1.1 Typical Sleeping Bag Packing Volume Loading System, Piston Structure