

International Standard



6889

INTERNATIONAL ORGANIZATION FOR STANDARDIZATION • МЕЖДУНАРОДНАЯ ОРГАНИЗАЦИЯ ПО СТАНДАРТИЗАЦИИ • ORGANISATION INTERNATIONALE DE NORMALISATION

Surface active agents — Determination of interfacial tension by drawing up liquid films

Agents de surface — Détermination de la tension interfaciale par étirement de films liquides

First edition — 1982-06-15

iTeh STANDARD PREVIEW
(standards.iteh.ai)

ISO 6889:1982

<https://standards.iteh.ai/catalog/standards/sist/c85f5b9d-6c28-4775-90c5-7327d72ceb1b/iso-6889-1982>

UDC 661.185 : 532.613.4

Ref. No. ISO 6889-1982 (E)

Descriptors : surfactants, tests, determination, interfacial tension.

Price based on 6 pages

Foreword

ISO (the International Organization for Standardization) is a worldwide federation of national standards institutes (ISO member bodies). The work of developing International Standards is carried out through ISO technical committees. Every member body interested in a subject for which a technical committee has been set up has the right to be represented on that committee. International organizations, governmental and non-governmental, in liaison with ISO, also take part in the work.

Draft International Standards adopted by the technical committees are circulated to the member bodies for approval before their acceptance as International Standards by the ISO Council.

iTeh STANDARD PREVIEW
(standards.iteh.ai)

International Standard ISO 6889 was developed by Technical Committee ISO/TC 91, *Surface active agents*, and was circulated to the member bodies in October 1980.

It has been approved by the member bodies of the following countries :

Austria	India	Romania
Belgium	Ireland	South Africa, Rep. of
China	Italy	Spain
Egypt, Arab Rep. of	Japan	Switzerland
France	Korea, Rep. of	USSR
Germany, F. R.	Netherlands	
Hungary	New Zealand	

<https://standards.iteh.ai/catalog/standards/sist/c85f5b9d-6c28-4775-90c5-7327d72c6b1d/iso-6889-1982>

No member body expressed disapproval of the document.

This International Standard cancels and replaces part of ISO Recommendation R 304-1963, of which it constitutes a technical revision.

Surface active agents — Determination of interfacial tension by drawing up liquid films

0 Introduction

Interfacial tension is a fundamental property of systems comprising two phases. This International Standard applies more particularly to two immiscible liquid phases containing one or more surface active agents.

The measurement of this characteristic, however, does not allow, in the case of solutions of surface active agents, any suppositions as to their detergency, emulsifying activities, etc. Indeed, no connection can be established between the performance properties of surface active agents and the interfacial tension of systems of two immiscible liquid phases.

1 Scope and field of application

This International Standard specifies a method by drawing up liquid films for the determination of the interfacial tension between two immiscible liquid phases, one aqueous and one organic, forming an interface. The two phases may contain one or more surface active agents.

The method is also applicable to the measurement of interfacial tension of systems of two immiscible liquid phases other than those mentioned above.

NOTES

1 Various methods have been established to determine interfacial tension, such as :

- a) methods by drawing up liquid films by a plate, stirrup or ring;
- b) drop volume method;
- c) drop sessile method;
- d) suspended drop method;
- e) rotated drop method.

Methods by drawing up liquid films have notable advantages, owing to the simplicity of the procedure.

2 The method described in this International Standard does not provide accurate values. It is acceptable for control in industrial laboratories in which the reproducibility of 2 mN/m* is sufficient for the range of interfacial tensions between 4 and 50 mN/m.

2 References

ISO/R 862, *Surface active agents — Glossary.*

ISO 2456, *Surface active agents — Water used as a solvent for tests.* **

3 Definitions

3.1 **free interfacial energy** : See ISO/R 862.

3.2 **interfacial tension** : See ISO/R 862.

NOTE — The SI unit of interfacial tension is the newton per metre (N/m). In practice, the sub-multiple millinewton per metre (mN/m) is used.

3.3 **age of the liquid-liquid interface** : The time which has elapsed between the formation of the interface in the measuring cup and drawing up of the interfacial liquid film.

4 Principle

Measurement of the maximum force which can be exerted before the film breaks, the force being exerted vertically on a stirrup or ring, in contact with the interfacial liquid film between two immiscible liquid phases placed in a measuring cup, in order to draw up the interfacial film.

The force has to pass through a maximum, otherwise the measurement is not valid.

* 1 mN/m = 1 dyn/cm

** At present at the stage of draft.

5 Apparatus

5.1 Tensiometer, which can be fitted with stirrups and rings, and which shall comprise :

- a) a **horizontal platform**, which can be moved vertically in both directions by means of a micrometer screw; it shall be fitted with a millimetric scale allowing estimation of vertical movements of 0,1 mm;
- b) a **dynamometer**, for continuous measurement of the force applied to the measuring unit with an accuracy of at least 0,1 mN/m;
- c) a **junction piece** between the lower end of the dynamometer and the upper end of measuring unit; this piece shall have an indicator for the "zero position" for the measuring unit, and also a device for wedging it;
- d) a **device** for indicating or recording the values measured by the dynamometer.

The assembly shall be shielded from vibrations and draughts.

5.2 Measuring unit, comprising at least one of the elements

a) and b), and also element c).

- a) A **stirrup**, of platinum-iridium wire of diameter not exceeding 0,1 mm; the length of the horizontal arms shall be 20 to 40 mm, and the length of the two vertical branches shall be 10 mm. The ends of these branches shall terminate in two small platinum balls which act as counterweights (see figure 1).
- b) A **ring**, of platinum-iridium wire, 0,3 mm in diameter. The circumference of the ring shall be generally between 40 and 60 mm. It shall be fixed to a suspending rod by means of a platinum wire stirrup (see figure 2).
- c) A **measuring cup**, to hold the test portion of the two-phase system to be examined, consisting of a small cylindrical glass tank of diameter at least 8 cm and height at least 4 cm.

In the case of a ring, when a smaller measuring cup is used, the ring has to be guided, since a wall effect may attract the ring to the wall of the measuring cup, and the forces measured will not then be perpendicular to the horizontal surface.

6 Procedure

6.1 Preparation of solutions of surface active agents

6.1.1 The solutions of surface active agents for the determination shall be prepared with all necessary care. The water used for their preparation shall be double-distilled water (see sub-clause 5.2 of ISO 2456), checked by measuring its surface tension. Cork stoppers and, more particularly, rubber stoppers, shall on no account be used, either in the construction of the distillation apparatus or for sealing containers in which the water is kept.

6.1.2 The temperature of the solutions shall be maintained to within 0,5 °C.

NOTE — Determinations carried out close to temperatures of critical solubility, such as the Krafft temperature or cloud point temperature of non-ionic surface active agents, are seriously affected by errors. It is preferable to carry out the test at a temperature higher than such temperatures or at a temperature lower than the cloud point temperature of non-ionic surface active agents.

6.1.3 As the interfacial tension of solutions varies with time, due to the mutual saturation of the liquid phases, and as the adsorption of surface active agents onto the interface are not instantaneous phenomena, it is difficult to recommend a standard age for the interface. It is, therefore, desirable to make several measurements over a period of time in order to obtain a curve for the interfacial tension as a function of time, and from this to determine the position of the plateau, which gives the age at which the interface reached its stationary state.

6.1.4 The surface of liquids is extremely sensitive to contamination by atmospheric dust or by vapours from solvents handled in the vicinity. Therefore no volatile products shall be handled in the room where the determinations are carried out, and all the apparatus shall be protected by a bell of the kind used for balances. These precautions also reduce variation in temperature.

6.1.5 The recommended method of taking the test portion of the liquid phases to be examined is to suck it, with a pipette, from the centre of the mass of these phases, as the surface may be liable to soiling by insoluble particles and dust.

6.2 Cleaning the apparatus

6.2.1 Cleaning the measuring cup

In the presence of soils such as silicones, which are not removed by sulpho-chromic acid mixtures, phosphoric acid or solutions of potassium persulphate in sulphonic acid, wash the measuring cup using special products (for example toluene, perchloroethylene or methanolic potassium hydroxide solution).

If these soils are absent, or after cleaning with these products, wash the measuring cup carefully with hot sulpho-chromic acid mixture, and then with concentrated phosphoric acid [83 to 98 % (m/m)]. Finally, rinse in double-distilled water until the rinsings are neutral.

The double-distilled water shall be freshly prepared in accordance with sub-clause 5.2 of ISO 2456.

Before the determination, the measuring cup shall be completely dried.

6.2.2 Cleaning the measuring unit

If necessary, clean the stirrup or ring (5.2) with the special products as described in 6.2.1. In the absence of soils requiring cleaning with these products, or after cleaning with these products, wash the platinum measuring unit with hot concentrated sulphuric acid ($\rho_{20} = 1,839$ g/ml), and then rinse with double-distilled water until neutral.

Dry the rings by passing them through a methanol flame for a few seconds. Do not touch the measuring units and the inner surface of the measuring cup with the fingers.

6.3 Determination

6.3.1 Levelling the tensiometer

Place a liquid level on the platform, and adjust the screws fixed in the base of the tensiometer until the platform is horizontal.

6.3.2 Preparation for the measurement

Attach the junction piece [5.1 c)] to the dynamometer [5.1 b)]. Connect the measuring unit to the junction piece. By means of the dynamometer, apply the force necessary to bring the indicator to the "zero position". Wedge the junction piece.

6.3.2.1 Case where the aqueous phase has the higher density

Place the measuring cup on the platform. Introduce, into the measuring cup, a sufficient volume, measured to the nearest 0,05 ml, of the aqueous phase to obtain a liquid height of about 15 mm. Strictly avoid foaming, by placing the end of the pipette against the lateral internal wall of the measuring cup.

Check that the arm of the stirrup, or the circumference of the ring, is horizontal, by using the surface of the aqueous phase as a mirror and observing the image of the measuring unit almost in contact with the surface of this phase.

NOTE — If the surface of the aqueous phase does not give a sufficiently clear image, remove the measuring cup. Place a mirror on the platform, checking that it is horizontal by means of a liquid level. Check that the arm of the stirrup, or the circumference of the ring, is horizontal as previously described.

Gently raise the platform with the measuring cup until the arm of the stirrup or the ring just touches the aqueous phase.

Then introduce the non-aqueous phase in sufficient volume to obtain a liquid height of about 15 mm. This volume shall be measured to the nearest 0,05 ml.

Strictly avoid the formation of droplets or bubbles at the interface.

6.3.2.2 Case where the aqueous phase has the lower density

Place the measuring cup on the platform. Introduce, into the measuring cup, a sufficient volume, measured to the nearest 0,05 ml, of the non-aqueous phase to obtain a liquid height of about 15 mm.

Then introduce, with all necessary care, a sufficient volume of the aqueous phase to obtain a liquid height of about 15 mm. This volume shall be measured to the nearest 0,05 ml.

Strictly avoid the formation of droplets or bubbles at the interface, and foaming at the surface of the aqueous phase, by placing the end of the pipette against the lateral internal wall of the measuring cup, above the surface of the non-aqueous phase.

Check that the arm of the stirrup, or the circumference of the ring, is horizontal, as described in 6.3.2.1.

Raise the platform with the measuring cup and immerse the measuring unit in the aqueous phase until the horizontal arm of the stirrup or the ring just touches the liquid-liquid interface.

6.3.3 Determination of force before drawing up the film

Unwedge the junction piece. By simultaneously adjusting the force applied by the dynamometer and the height of the platform, bring the horizontal arm of the stirrup or the circumference of the ring to the height of the liquid-liquid interface, and the indicator of the junction piece to the "zero position". Wedge the junction piece.

Wait until the time corresponding to the desired age for the liquid-liquid interface (see 3.3) has elapsed, then unwedge the junction piece. If the indicator is displaced from the "zero position", bring it back to the initial position by adjusting the force applied by the dynamometer. Carefully note the force which maintains the "zero position" (see figure 4). The value of this force F_1 is the "force before drawing up the film".

6.3.4 Determination of the force after drawing up the film

6.3.4.1 Case where the aqueous phase has the higher density

Gently lower the platform through 0,1 mm by means of the micrometer screw. Bring back the indicator to the "zero position" without passing it, by suitably increasing the force applied by the dynamometer to the measuring unit. Carefully note the value of this force.

Repeat the operations described in the last paragraph until the interfacial liquid film breaks.

The value of the force noted just before the film breaks, F_2 , is the "force after drawing up the film".

6.3.4.2 Case where the aqueous phase has the lower density

Gently raise the platform through 0,1 mm by means of the micrometer screw. Bring back the indicator to the "zero position" without passing it, by suitably decreasing the force applied by the dynamometer to the measuring unit. Carefully note the value of this force.

Repeat the operations described in the last paragraph until the interfacial liquid film breaks.

The value of the force noted just before the film breaks, F_3 , is the "force after drawing up the film".

6.3.5 Repetition of determinations

Carry out the determinations described in 6.3.2 to 6.3.4 several times, using each time new test portions for the two liquid phases. The volumes of these phases shall always be the same, to the nearest 0,05 ml, as those used for the first determination.

6.3.6 Force for drawing up the film

6.3.6.1 Case where the aqueous phase has the higher density

The "force for drawing up the film", designated ΔF , is the mean value of the differences $F_2 - F_1$ between the forces applied by the dynamometer to the measuring unit after and before drawing up the interfacial liquid film.

6.3.6.2 Case where the aqueous phase has the lower density

The "force for drawing up the film", designated ΔF , is the mean value of the differences $F_1 - F_3$ between the forces applied by the dynamometer to the measuring unit before and after drawing up the interfacial liquid film.

6.4 Calibration

NOTE — Generally, except in case of a stirrup, the application of theoretical formulae giving the value of the interfacial tension as a function of the force exerted by the dynamometer on the measuring unit and of its geometry, does not always allow determination of exact values of the interfacial tension. Sometimes, with systems having two mutually saturated pure liquid phases, the values obtained differ widely from those given in literature. It is necessary, therefore, to calibrate each measuring unit.

For determinations not requiring very great precision, the stirrup or the ring may be calibrated by using two-phase systems comprising two mutually saturated, superficially pure liquids having a known interfacial tension and densities similar to those of the two-phase system to be examined. In these conditions, a direct relationship may be assumed between the values of interfacial tension and the forces applied by the dynamometer to the measuring unit to draw up the interfacial liquid film so that it does not break.

Carry out the calibration using the procedure described in 6.3 using a standard two-phase system comprising two mutually saturated superficially pure liquids, having a known interfacial tension and densities similar to those of the system to be examined. Ensure that the volumes of the phases of the standard system are the same, to the nearest 0,05 ml, as those of the system to be examined.

Values of the interfacial tension between water and some organic liquids are given in the annex.

7 Expression of results

7.1 Method of calculation

The interfacial tension, γ , in millinewtons per metre, is given by the formula

$$\gamma_{\text{et}} \times \frac{\Delta F}{\Delta F_{\text{et}}}$$

where

γ_{et} is the interfacial tension, in millinewtons per metre, of the standard two-phase system;

ΔF is the "force for drawing up the film", in millinewtons, of the two-phase system examined;

ΔF_{et} is the "force for drawing up the film", in millinewtons, of the standard two-phase system.

7.2 Precision

The accuracy of determinations of interfacial tension varies considerably according to the nature of the two phases of the system examined and their wetting power towards platinum.

7.3 Reproducibility

The difference between the results obtained on the same sample, in two different laboratories, should not exceed 2 mN/m.

8 Test report

The test report shall include the following information :

- all information necessary for the complete identification of the system examined, including details of sampling, and, in the case of solutions of surface active agents, critical solubility temperatures, such as the Krafft temperature, cloud point temperature of non-ionic surface active agents, etc.;
- the reference of the method used (reference to this International Standard) together with an indication of the measuring unit used (stirrup or ring) and the diameter of the measuring cup;
- the nature of the two liquid phases of the system examined and the concentration of products dissolved in these phases;
- the temperature of the determination;
- the age of the interface;
- the results and the method of expression used;
- any operating details not specified in this International Standard, or regarded as optional, as well as any incidents liable to have affected the results.

Dimensions in millimetres

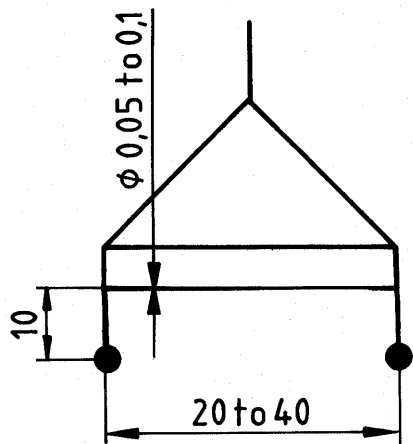

Figure 1 – Stirrup [5.2 a)]

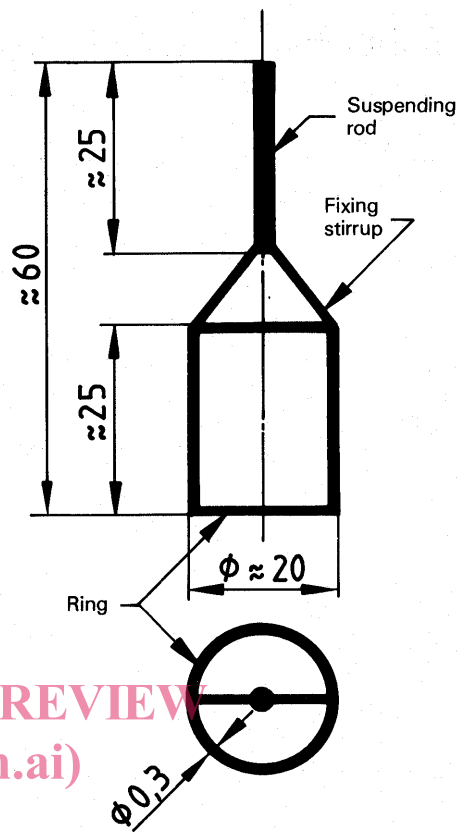

Figure 2 – Ring [5.2 b)]

iTeh STANDARD PREVIEW
(standards.iteh.ai)

ISO 6889:1982

<https://standards.iteh.ai/catalog/standards/sist/c85f5b9d-6c28-4775-90c5-7327d72ceb1b/iso-6889-1982>

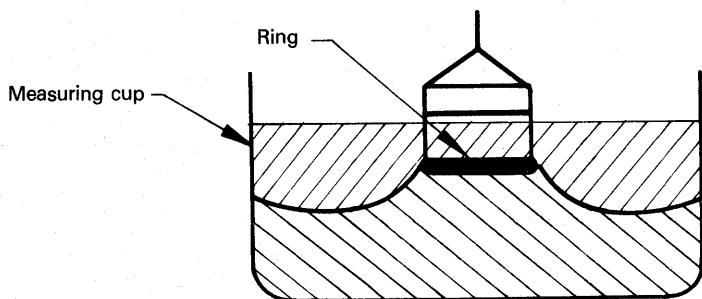

Figure 3 – Measurement using a ring

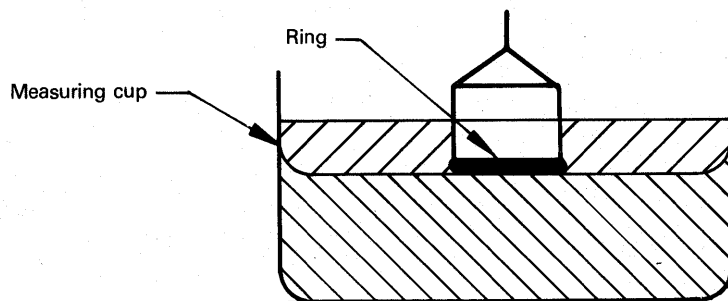

Figure 4 – Ring at "zero position"

Annex

Values of interfacial tension between water and some organic liquids at 20 °C

NOTE — Each phase is previously saturated by the other phase of the system.

Organic liquid	Interfacial tension
	mN/m
Heptanoic acid	7,0
Benzaldehyde	15,5
Nitrobenzene	25,2
Benzene	35,0
Carbon tetrachloride	45,0
Heptane	50,2

iTeh STANDARD PREVIEW
(standards.iteh.ai)

[ISO 6889:1982](https://standards.iteh.ai/catalog/standards/sist/c85f5b9d-6c28-4775-90c5-7327d72ceb1b/iso-6889-1982)

<https://standards.iteh.ai/catalog/standards/sist/c85f5b9d-6c28-4775-90c5-7327d72ceb1b/iso-6889-1982>