



Designation: A 987 – 00

Standard Test Method for Measuring Shape Characteristics of Tin Mill Products¹

This standard is issued under the fixed designation A 987; the number immediately following the designation indicates the year of original adoption or, in the case of revision, the year of last revision. A number in parentheses indicates the year of last approval. A superscript epsilon (ϵ) indicates an editorial change since the last revision or reapproval.

1. Scope

1.1 Shape is a significant quality characteristic for tin mill products. Plate-shape is affected by mill process factors plus the temper, thickness and width of the material supplied. It is the purpose of this test method to define accurately the different plate shape characteristics and to describe the method(s) most commonly used to measure particular characteristics.

1.2 Quantitative limits are not addressed and should be established on an individual producer and user basis, where appropriate.

1.3 *This standard does not purport to address the safety concerns, if any, associated with its use. It is the responsibility of the user of this standard to establish appropriate safety and health practices and to determine the applicability of regulatory limitations prior to use.*

2. Referenced Documents

2.1 ASTM Standards:

- A 599/A 599M Specification for Tin Mill Products, Electrolytic Tin Coated, Cold-Rolled Sheet²
- A 623 Specification for Tin Mill Products, General Requirements²
- A 623M Specification for Tin Mill Products, General Requirements [Metric]²
- A 624/A 624M Specification for Tin Mill Products, Electrolytic Tin Plate, Single Reduced²
- A 625/A 625M Specification for Tin Mill Products, Black Plate, Single Reduced²
- A 626/A 626M Specification for Tin Mill Products, Electrolytic Tin Plate Double Reduced²
- A 650/A 650M Specification for Tin Mill Products, Black Plate, Double Reduced²
- A 657/A 657M Specification for Tin Mill Products, Black Plate Electrolytic Chromium-Coated, Single and Double Reduced²

¹ This test method is under the jurisdiction of ASTM Committee A01 on Steel, Stainless Steel, and Related Alloys and is the direct responsibility of Subcommittee A01.20 on Tin Mill Products.

Current edition approved Oct. 10, 2000. Published November 2000. Originally published as A 987-98. Last previous edition A 987-98.

² *Annual Book of ASTM Standards*, Vol 01.06.

3. Classification

3.1 The substrate shall conform to all the requirements of the appropriate specifications as follows: Specifications A 623, A 623M, A 599/A 599M, A 624/A 624M, A 625/A 625M, A 626/A 626M, A 650/A 650M, and A 657.

4. Significance and Use

4.1 The definitions and procedures for measuring shape characteristics of tin mill products are provided so that purchasers and suppliers have common measuring procedures and definitions of shape characteristics. These procedures provide definitions and measuring techniques of shape characteristics. The intention of these definitions and measuring methods is not to provide a dimensional specification for shape characteristics, but rather common procedure(s) for quantifying shape anomalies.

5. Interferences

5.1 Measurement of shape often has been subjective, at best. Successful measurement of various shape anomalies on quantitative terms requires recognition of several factors that can interfere with accurate measurements.

5.1.1 Flat surfaces are required. Measurement of several anomalies require laying of the sample on a flat surface. A machined flat surface is recommended. Laying a sample on a floor may introduce error due to areas on a floor that are not flat.

5.1.2 Several anomalies are measured by hanging the sheet. Hanging by holding the sample with a hand can introduce error from pressures exerted by fingers. A mechanical single device clamp to help hold these samples is recommended.

5.1.3 Stepblock gages or tapered gages should be checked regularly with a calibrated hand micrometer. Wear or dirt build up could affect accuracy.

5.1.4 The ShapemasterTM³ table must be clean and the sensors must be in good condition. The sheet sample must be damage free.

³ A contact or noncontact flatness measuring instrument, manufactured by SP&C Computer Systems, Inc., 7292 Park Drive, Bath, PA 18014. See Figs. 1 and 2 of the noncontact, laser sensor, Shapemaster TL 1000 shape gage in use. Other instruments of appropriate design also may be used.

6. Apparatus

6.1 Appropriate tools to measure shape anomalies are described along with drawings (attached) as required.

6.1.1 *Flat Surfaces*—Accurate measurements of shape anomalies require a flat surface, machined flat preferred.

6.1.2 *Machined Stepblock Gage*—See Fig. 3, typically, steps are in $\frac{1}{16}$ -in. increments.

6.1.3 *Tapered Gage*—See Fig. 4.

6.1.4 *Standard Ruler or Tape Measure*.

6.1.5 *Hand Micrometer*.

6.1.6 *Shape Test Jig*—Fig. 5, or other shape test jigs of appropriate design.

6.1.7 *Light-Weight Straight-Edge*.

6.1.8 The Shapemaster^{TM3} shape gage is a computer-based system designed for flatness measurements on samples of cold rolled sheet products. The system consists of a large steel table, computer-based operator's console, and a motor-driven bridge containing one or more LVDT position sensors to contact the strip or by use of a laser sensor, noncontact measuring system.

7. Procedure

Definitions and Measuring Methods of Shape Anomalies

7.1 *Wavy Edge (See Fig. 6):*

7.1.1 *Definition*—A series of rolling direction edge deviations from a recognized flat surface. When a sample is placed on a recognized flat table, wavy edges will appear as undulations along the edge, having the height (*A*) and a measurable cycle (*B*). This defect can be quantified using the “*T*” unit (see Section 8) or steepness calculations.

7.1.2 *Measuring Methods:*

7.1.2.1 A sample of approximately 3 ft [0.9 m] in length by coil width is placed on a flat table. Measure the height (*A*) at the peak point of each wave from the recognized flat surface with a tapered gage or a stepblock gage. Also measure the cycle length (*B*) from peak to peak of each wave with a ruler or tape measure.

7.1.2.2 Measure using the ShapemasterTM or other instrument of appropriate design.

7.2 *Ridge Buckle, Quarter Buckle, Center Buckle (see Fig. 7):*

7.2.1 *Definition*—These buckles are continuous deviations from a recognized flat surface occurring usually in narrow width areas parallel to the rolling direction other than at the sheet edges.

7.2.2 *Measuring Methods:*

7.2.2.1 A sheet sample of approximately 3 ft [0.9 m] by coil width is placed on a flat table. Push material diagonally along the sample to within 4 in. [10 cm] of the selected corner and measure the vertical uplift using a tapered gage or a stepblock gage.

7.2.2.2 Shear through the center line of the shape anomaly and measure as an edge wave using a tapered gage or a stepblock gage.

7.2.2.3 Measure using the ShapemasterTM or other instrument of appropriate design.

7.3 *Full Center (see Fig. 8):*

7.3.1 *Definition*—Any overall deviation of a sheet from a recognized flat surface occurring over a major portion of the sheet width parallel to the rolling direction other than at the sheet edges.

7.3.2 *Measuring Methods:*

7.3.2.1 A sheet sample of approximately 3 ft [0.9 m] by coil width is placed on a flat table. Push material diagonally along the sample to within 4 in. [10 cm] of the selected corner and measure the vertical uplift using a tapered gage or a stepblock gage.

7.3.2.2 Shear through the center line of the shape anomaly and measure as an edge wave using a tapered gage or a stepblock gage.

7.3.2.3 Measure using the ShapemasterTM or other instrument of appropriate design.

7.4 *Edge Lift (see Fig. 9):*

7.4.1 *Definition*—Any deviation of one sheet edge other than a wavy edge. This edge lift is parallel to the rolling direction and rises when placed on a recognized flat surface.

7.4.2 *Measuring Method*—A sheet sample of approximately 3 ft [0.9 m] by coil width is placed on a flat table. Push material diagonally along the sheet to within 4 in. [10 cm] of the selected edge and measure the vertical distance (*A*) with a tapered gage, a stepblock gage, or a standard ruler.

7.5 *Coil Set and Reverse Coil Set (see Fig. 10):*

7.5.1 *Definition*—A bow condition or deviation in the sheet as measured from a recognized flat surface. The deviation runs parallel with the rolling direction and takes the shape of a coil. Reverse coil set reverses the shape of a coil. The degree of coil set usually is determined in a vertical, free-hanging position when held against a straight-edge. Use of the shape test jig (Fig. 5) is highly recommended for this measurement.

7.5.2 *Measuring Methods:*

7.5.2.1 A sheet sample of approximately 3 ft [0.9 m] by coil width should be held by a clamp or with the thumb and index finger. Hold the sample in the center of the rolling direction dimension. Hold the sample's edges against a recognized straight edge, and measure the deviation (*A*) from the edge to the center of the sample. Use a rule accurate to $\frac{1}{16}$ in. [or 1 mm].

7.5.2.2 Measure the edge rise (*A*) of the sheet laying on a recognized flat surface.

7.6 *Twist (see Fig. 11):*

7.6.1 *Definition*—A combination of shape anomalies that results in a twisting of the sheet where diagonal corners will bow in opposite directions when the sheet is held in a vertical, free-hanging position.

7.6.2 *Measuring Methods:*

7.6.2.1 A sheet sample of approximately 3 ft [0.9 m] by coil width should be placed on a flat table. Measure the edge lift (*A*) on one side then turn the sheet over and measure the edge lift on the other side of the sample. Measure using a tapered gage or a stepblock gage.

7.6.2.2 A sheet sample of approximately 3 ft [0.9 m] by coil width should be held by a clamp or with the thumb and index finger in the center of the rolling direction dimension. Measure the amount of the twist by the deviation of one of the corners

from a flat surface using a ruler. Flip the sample 180° and measure the deviation from vertical of the other corner, using a ruler.

7.7 Crossbow (see Fig. 12):

7.7.1 *Definition*—An edge deviation in the sheet running perpendicular to the rolling direction. Both rolling direction edges are raised measurable amounts (A) from a recognized flat surface. The degree of cross bow usually is determined in a vertical, free-hanging position held against a straight edge. Use of the shape test jig (Fig. 5) is highly recommended for this measurement.

7.7.2 Measuring Methods:

7.7.2.1 A sheet sample of approximately 3 ft [0.9 m] by coil width should be held by a clamp or with the thumb and the index finger in the center of sheet dimension that is perpendicular to the rolling direction. In case of dispute, a clamp no more than 2 in. [50.8 mm] wide shall be used to hold the test sample. Hold the sample's edges against a recognized straight edge, and measure the deviation (A) from the straight edge to center of the sample. Use a rule accurate to $\frac{1}{16}$ in. [or 1 mm].

7.7.2.2 Measure the edge rise of a sheet lying on a flat surface.

7.8 Camber (see Fig. 13):

7.8.1 *Definition*—The greatest deviation of a coil edge from a straight line. The measurement is taken on the concave side and is the perpendicular distance from a straight line to the point of maximum deviation (A).

7.8.2 Methods of Measurement:

7.8.2.1 A sample of at least 20 ft [6 m] is laid next to an accurate straight edge. The perpendicular distance (A) is measured using a ruler accurate to $\frac{1}{16}$ in. [or 1 mm].

7.8.2.2 *Alternate Method of Measurement—Macro Analysis*—Cut two 20-ft [6-m] consecutive sections from master coil. Butt together the sections with similar edges. At a 10-ft [3-m] distance from the end, measure the distance between the two edges. Divide this measurement in half to determine the actual camber.

7.8.2.3 *Alternate Method of Measurement—Micro Analysis*—Obtain consecutive customer sheared sheets equivalent to 20 ft [6 m]. Using a squaring table with a sliding gage set at zero, slide the gages right to left along one slit edge. The reading on the extreme left slit edge of Sheet No. 1 will be the

beginning reading on the extreme right edge of Sheet No. 2. This procedure should be used from consecutive sheet to consecutive sheet until 20 ft [6 m] have been measured. Divide the final measurement in half to determine the actual camber.

7.9 Lateral Weave (see Fig. 14):

7.9.1 *Definition*—Weave is defined as oscillation of the coil or sheet edge from a straight line. The measurement is taken on the concave side and is the perpendicular distance from a straight line to the point of maximum deviation (A).

7.9.2 Measuring Methods:

7.9.2.1 *Macro Analysis*—A sheet sample of at least 20 ft [6 m] in length is laid next to an accurate straight edge. The perpendicular distance (A) is measured using a ruler accurate to $\frac{1}{16}$ in. [or 1 mm].

7.9.2.2 *Micro Analysis*—Obtain consecutive customer sheared sheets equivalent to 20 ft [6 m]. Using a squaring table with a sliding gage set at zero, slide to gages right to left along one slit edge. The reading on the extreme left slit edge of Sheet No. 1 will be the beginning reading on the extreme right edge of Sheet No. 2. This procedure should be used from consecutive sheet to consecutive sheet until 20 ft [6 m] have been measured. The individual measurements then are plotted, the maximum value being the maximum weave deviation.

8. I-U Calculation

8.1 This calculation assumes that shape irregularities most closely conform to sinusoidal wave forms and uses the shape wave length and height for the calculation. An alternate approach is to use % steepness as a measure of the severity of shape imperfections (see Fig. 15).

9. Precision and Bias

9.1 *Precision*—Precision is not specified in these procedures for this test method. The procedures are provided so that purchasers and suppliers have common methodology and definitions of shape characteristics.

9.2 *Bias*—Since there is no accepted reference material suitable for determining the bias of the procedures in this test method, bias has not been determined.

10. Keywords

10.1 coated steel sheet; shape characteristics; tin mill products; tinplate

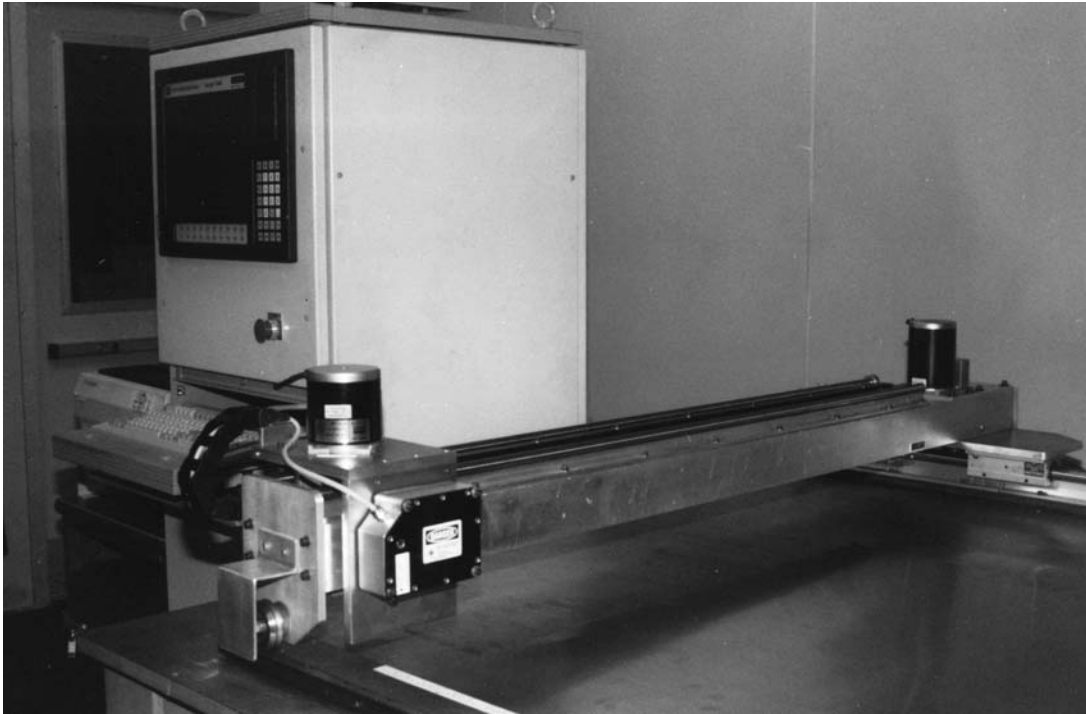
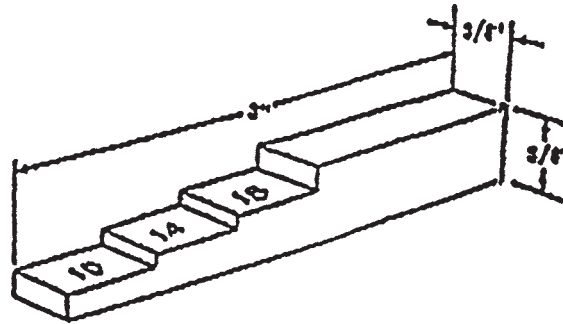

FIG. 1 Shapemaster TL1000 Shape Gage



FIG. 2 Shapemaster TL1000 Shape Gage



NOTE 1—This is a stepblock gage for all thicknesses and sizes of cut sheets.
 NOTE 2—Dimensions given are approximate overall dimensions.

FIG. 3 Shape Stepblock Gage



NOTE 1—This is a tapered gage for all thicknesses and sizes of cut sheets.

FIG. 4 Shape Tapered Gage

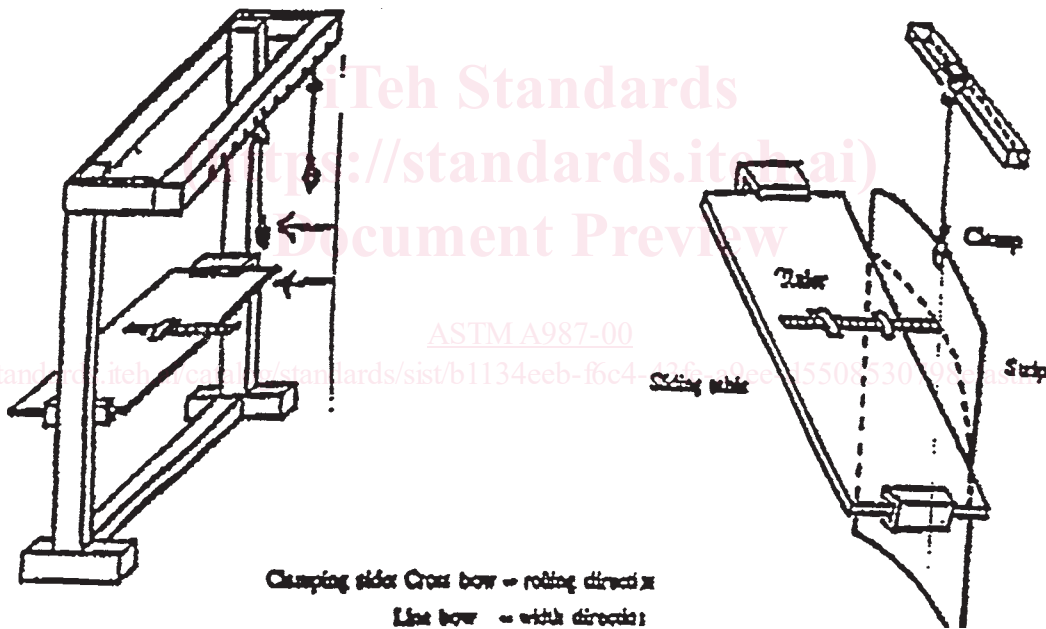

NOTE 1—To measure line bow (up or down) requires the use of a shape test jig.

FIG. 5 Shape Test Jig

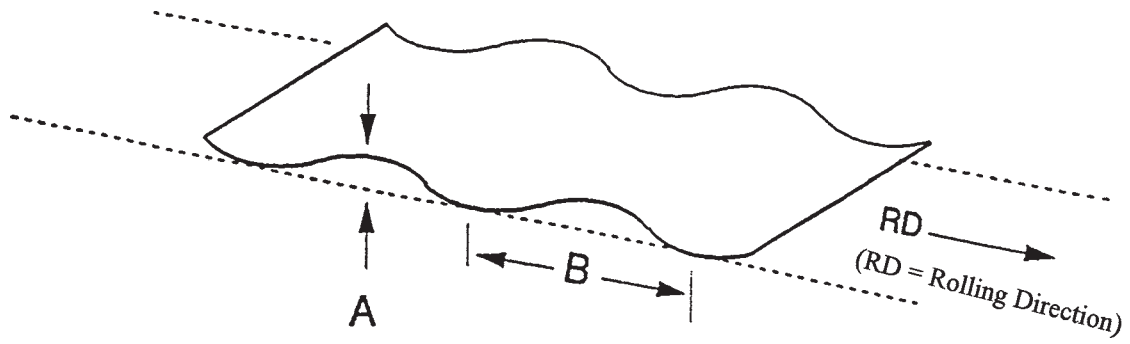

FIG. 6 Wavy Edge

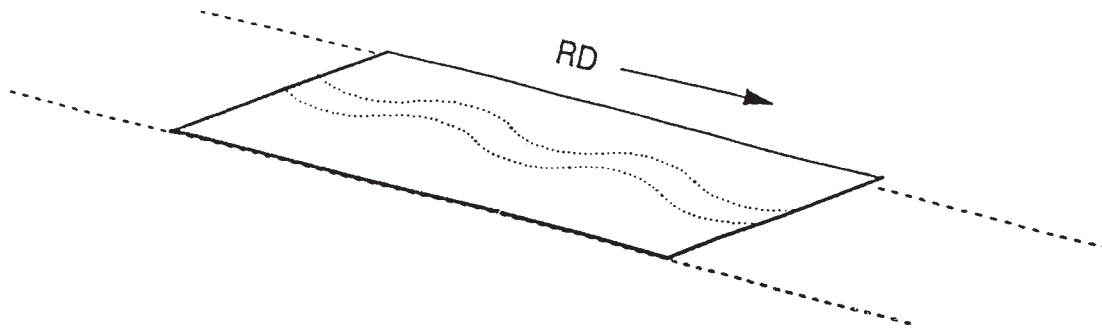

FIG. 7 Ridge Buckle, Quarter Buckle, Center Buckle

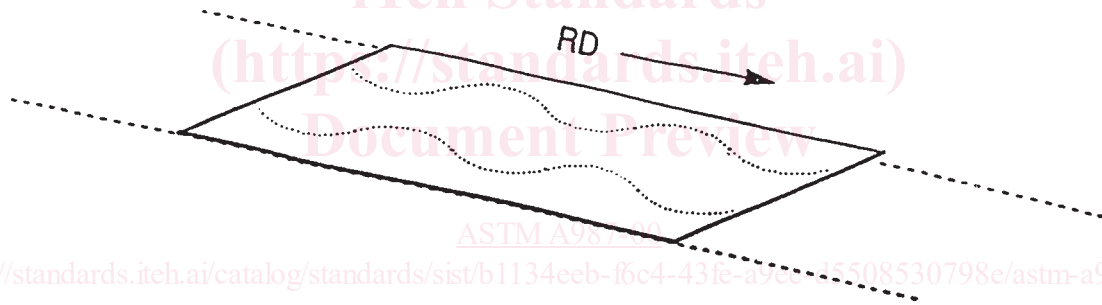

FIG. 8 Full Center

ASTM A 987 - 00
<https://standards.iteh.ai/catalog/standards/sist/b1134eeb-f6c4-43fe-a9ce-15508530798e/astm-a987-00>