**Vitreous and porcelain enamels —
Determination of resistance to boiling citric
acid**

Émaux vitrifiés — Détermination de la résistance à l'acide citrique bouillant

iTeh STANDARD PREVIEW
(standards.iteh.ai)

[ISO 2742:1998](https://standards.iteh.ai/catalog/standards/sist/dac267b-03e0-45e2-a52e-23cc94ae1ee/iso-2742-1998)

<https://standards.iteh.ai/catalog/standards/sist/dac267b-03e0-45e2-a52e-23cc94ae1ee/iso-2742-1998>



Foreword

ISO (the International Organization for Standardization) is a worldwide federation of national standards bodies (ISO member bodies). The work of preparing International Standards is normally carried out through ISO technical committees. Each member body interested in a subject for which a technical committee has been established has the right to be represented on that committee. International organizations, governmental and non-governmental, in liaison with ISO, also take part in the work. ISO collaborates closely with the International Electrotechnical Commission (IEC) on all matters of electrotechnical standardization.

Draft International Standards adopted by the technical committees are circulated to the member bodies for voting. Publication as an International Standard requires approval by at least 75 % of the member bodies casting a vote.

International Standard ISO 2742 was prepared by Technical Committee ISO/TC 107, *Metallic and other inorganic coatings*, Subcommittee SC 6, *Vitreous and porcelain enamels*.

This third edition cancels and replaces the second edition (ISO 2742:1983), which has been technically revised.

Annex A of this International Standard is for information only.

© ISO 1998

All rights reserved. Unless otherwise specified, no part of this publication may be reproduced or utilized in any form or by any means, electronic or mechanical, including photocopying and microfilm, without permission in writing from the publisher.

International Organization for Standardization
Case postale 56 • CH-1211 Genève 20 • Switzerland
Internet central@iso.ch
X.400 c=ch; a=400net; p=iso; o=isocs; s=central

Printed in Switzerland

Vitreous and porcelain enamels — Determination of resistance to boiling citric acid

1 Scope

This International Standard specifies a method of test for determining the resistance of flat surfaces of vitreous and porcelain enamels to pure boiling citric acid.

It is especially intended for the testing of enamels for articles which are used with boiling, slightly dissociated acids, for example cooking utensils.

NOTE — This method of test is also suitable for determining the chemical resistance of enamels to other acid solutions.

This method of test is not suitable for enamels used in the chemical industry or those exposed to heavy attack by inorganic acids for a long period.

For testing enamels at room temperature, see ISO 2722.

For testing acid resistance of enamels for containers and apparatus for the chemical industry, see ISO 2743.

<https://standards.iteh.ai/catalog/standards/sist/dac267b-03e0-45e2-a52e-23cc94ae1ee/iso-2742-1998>

2 Normative references

The following standards contain provisions which, through reference in this text, constitute provisions of this International Standard. At the time of publication, the editions indicated were valid. All standards are subject to revision, and parties to agreements based on this International Standard are encouraged to investigate the possibility of applying the most recent editions of the standards indicated below. Members of IEC and ISO maintain registers of currently valid International Standards.

ISO 2723 : 1995,	<i>Vitreous and porcelain enamels for sheet steel - Production of specimens for testing.</i>
ISO 2724 : 1973,	<i>Vitreous and porcelain enamels for cast iron - Production of specimens for testing.</i>
ISO 2733 : 1983,	<i>Vitreous and porcelain enamels - Apparatus for testing with acid and neutral liquids and their vapours.</i>
ISO 3585 : 1991,	<i>Borosilicate glass 3.3 - Properties.</i>
ISO 4788 : 1980,	<i>Laboratory glassware - Graduated measuring cylinders.</i>

3 Principle

An enamelled test specimen is exposed to a boiling 6 % (*m/m*) solution of citric acid for 2,5 h which, if information is desired on the further corrosion curve, may be extended to 6 h, 24 h or longer. The test specimen is placed in the liquid zone of the test apparatus.

The loss in mass is determined, from which the loss in mass per unit area is calculated.

NOTE — The lower the loss in mass per unit area, the higher is the resistance of the vitreous and porcelain enamel to boiling citric acid.

4 Reagents

During the determination, use only reagents of recognized analytical grade and only distilled water, or water of equivalent purity.

4.1 Citric acid, 6 % (*m/m*) solution.

Dissolve 33 g of pure crystalline citric acid ($C_6H_8O_7 \cdot H_2O$) in 500 ml of distilled or demineralized water.

A fresh solution, prepared the same day, is required for each test.

4.2 **Cleaning medium**, for example ethanol, (C_2H_5OH) or water containing a few drops of liquid detergent, for cleaning and degreasing the test specimen.

5 Apparatus

5.1 Test apparatus and packing B or C, both complying with ISO 2733.

The top of the testing apparatus shall comprise a plate made of borosilicate glass 3.3 complying with ISO 3585.

5.2 Drying oven, capable of maintaining temperatures of at least 130 °C.

5.3 Desiccator, for example with an internal diameter of 200 mm.

5.4 Graduated measuring cylinder, capacity 500 ml, complying with ISO 4788.

5.5 Beakers.

5.6 Balance, accurate to 0,2 mg.

5.7 Sponge, soft.

6 Test specimens

6.1 Prepare two test specimens in accordance with the International Standards for the appropriate base metal.

The test specimens for testing vitreous and porcelain enamels for sheet steel and for cast iron shall be prepared in accordance with ISO 2723 and ISO 2724, respectively.

6.2 Rinse each test specimen with water. If necessary, use a suitable cleaning and degreasing medium (4.2). Then dry the test specimens for 2 h in the drying oven (5.2) maintained at (110 ± 5) °C. Allow the test specimens to stand for at least 2 h in the desiccator (5.3) and finally weigh them to the nearest 0,2 mg (starting mass).

7 Procedure

7.1 Carry out one determination for each test specimen.

7.2 Fix the test specimen in the test apparatus (5.1) so that it forms the bottom of the cylinder and the cover coat side of the test specimen is facing the interior of the cylinder.

Fix the glass plate (see 5.1) so that it forms the top of the cylinder.

iTeh STANDARD PREVIEW
(standards.iteh.ai)

Screw down the three wing-nuts evenly to ensure that the test apparatus is watertight.

7.3 Run 450 ml of the citric acid (4.1) into the test apparatus through the socket for the reflux condenser, replace the latter and switch on the heater.

To ensure that the citric acid (4.1) begins to simmer, a simmering aid as shown in figure 1, made of borosilicate glass 3.3 complying with ISO 3585, may be introduced into the cylinder of the test apparatus (5.1) such that it is immersed into the solution of citric acid (4.1).

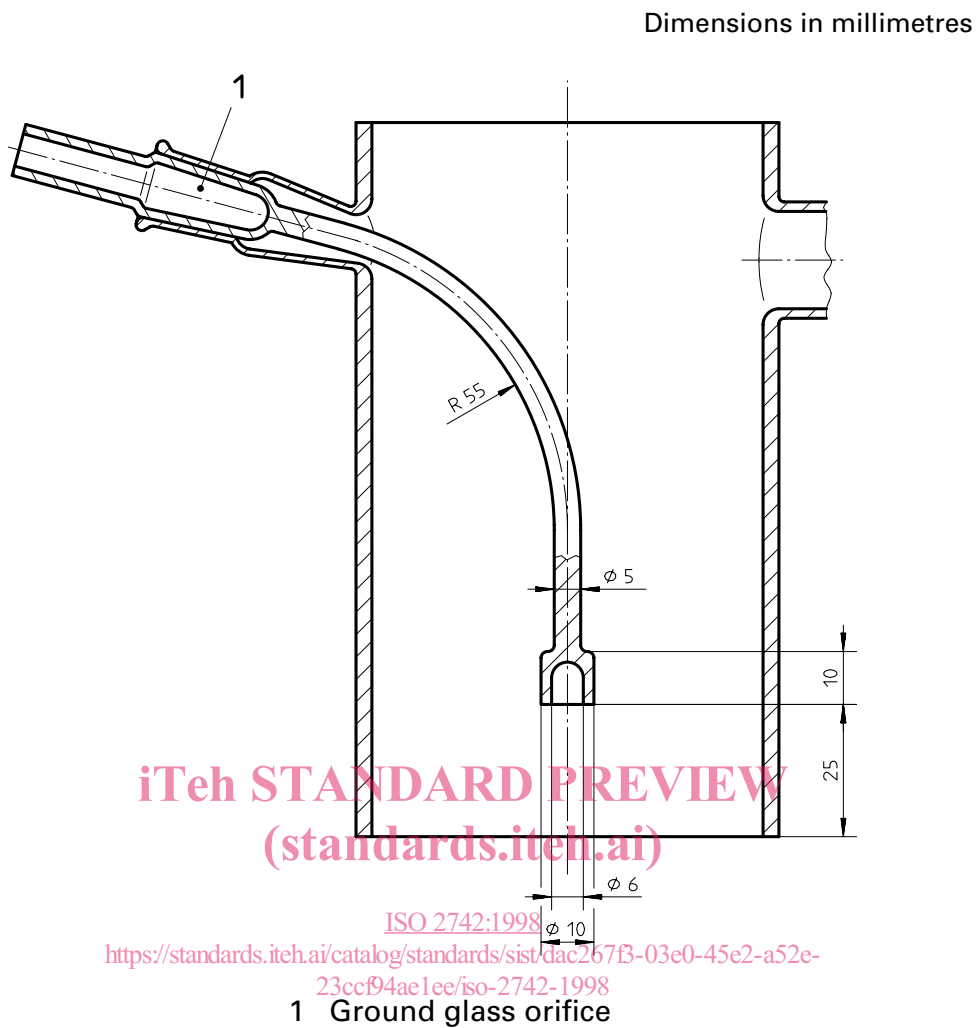

Figure 1 — Cylinder of the test apparatus with a simmering aid

As soon as the solution is boiling vigorously, adjust its rate of boiling by means of the heat-control device so that the condensate discharges from the condenser at the rate of 30 drops per minute to 50 drops per minute.

7.4 The duration of boiling shall be 2,5 h (150 min), but it is recommended that the tests be prolonged, for example to 6 h, 24 h or longer, since experience has shown that the attack diminishes considerably with time.

7.5 After boiling for 2,5 h (150 min) or longer, as appropriate, empty the cylinder, cool and rinse it with water.

Take the test specimen from the test apparatus and wipe it at least three times with the sponge (5.7), previously soaked in water.

Carefully remove any packing residues from the edges of the specimen and dry it for 2 h in the drying oven (5.2) maintained at $(110 \pm 5) ^\circ\text{C}$. Allow the test specimens to cool for 2 h in the desiccator (5.3) and weigh it to the nearest 0,2 mg (final mass).

7.6 Disregard test specimens which show defects such as pinholes down to the metal, chipped edges or edge corrosion and test a corresponding number of new specimens.

8 Expression of results

8.1 The loss in mass per unit area, $\Delta\rho_A$, expressed in grams per square metre, is given by the equation

$$\Delta\rho_A = \frac{\Delta m \times 10^4}{50} = 200 \Delta m$$

where

Δm is the loss in mass of the test specimen (starting mass minus final mass), in grams;

50 is the exposed area of the test specimen, in square centimetres;

In order to distinguish between the test results of different test periods, the number of test hours is to be stated as a subscript to the symbol; for example,

— for 2,5 h test time, $\Delta\rho_{A2,5}$

— for 6 h test time, $\Delta\rho_{A6}$

— for 24 h test time, $\Delta\rho_{A24}$

iTeh STANDARD PREVIEW
(standards.iteh.ai)

ISO 2742:1998

<https://standards.iteh.ai/catalog/standards/sist/dac267b-03e0-45e2-a52e-23ccb94ae1ee/iso-2742-1998>

8.2 Calculate the arithmetic mean of the two individual values. The difference between the individual values of the loss in mass per unit area ($\Delta\rho_A$) shall not exceed 30 % of the arithmetic mean. Otherwise, a further test shall be carried out. The two values shall be taken into account in calculating a new arithmetic mean.

9 Test report

The test report shall include the following information:

a) reference to this International Standard, i. e. "determined in accordance with ISO 2742:1998";

b) identification of the enamel tested;

c) the duration of boiling, in hours;

d) the loss in mass per unit area, $\Delta\rho_{A2,5}$, and, if further tests have been carried out, $\Delta\rho_{A6}$, $\Delta\rho_{A24}$ and $\Delta\rho_{A..}$, expressed in grams per square metre, rounded to the nearest 0,1 g·m⁻², giving the arithmetic mean and the number of individual values.

Annex A
(informative)

Bibliography

- [1] ISO 2722:1997, *Vitreous and porcelain enamels - Determination of resistance to citric acid at room temperature.*
- [2] ISO 2743:1986, *Vitreous and porcelain enamels - Determination of resistance to condensing hydrochloric acid vapour.*

iTeh STANDARD PREVIEW
(standards.iteh.ai)

[ISO 2742:1998](https://standards.iteh.ai/catalog/standards/sist/dac267B-03e0-45e2-a52e-23ccf94ae1ee/iso-2742-1998)

<https://standards.iteh.ai/catalog/standards/sist/dac267B-03e0-45e2-a52e-23ccf94ae1ee/iso-2742-1998>

iTeh STANDARD PREVIEW
(standards.iteh.ai)

ISO 2742:1998

<https://standards.iteh.ai/catalog/standards/sist/dac267B-03e0-45e2-a52e-23ccf94ae1ee/iso-2742-1998>