



Designation: C 1399 – 01

Test Method for Obtaining Average Residual-Strength of Fiber-Reinforced Concrete¹

This standard is issued under the fixed designation C 1399; the number immediately following the designation indicates the year of original adoption or, in the case of revision, the year of last revision. A number in parentheses indicates the year of last reapproval. A superscript epsilon (ϵ) indicates an editorial change since the last revision or reapproval.

1. Scope

1.1 This test method covers the determination of residual strength of a fiber-reinforced concrete test beam. The average residual strength is computed for specified beam deflections beginning after the beam has been cracked in a standard manner. The test provides data needed to obtain that portion of the load-deflection curve beyond which significant cracking damage has occurred and it provides a measure of post-cracking strength, as such strength is affected by the use of fiber-reinforcement.

1.2 *This standard does not purport to address all of the safety concerns, if any, associated with its use. It is the responsibility of the user of this standard to establish appropriate safety and health practices and determine the applicability of regulatory limitations prior to use.*

1.3 The values stated in SI units are to be regarded as the standard. The values in parentheses are for information only.

2. Referenced Documents

2.1 ASTM Standards:

C 31 Practice for Making and Curing Concrete Test Specimens in the Field²

C 42 Test Method for Obtaining and Testing Drilled Cores and Sawed Beams of Concrete²

C 78 Test Method for Flexural Strength of Concrete (Using Simple Beam with Third-Point Loading)²

C 172 Practice for Sampling Freshly Mixed Concrete²

C 192 Practice for Making and Curing Concrete Test Specimens in the Laboratory²

C 823 Practice for Examining and Sampling of Hardened Concrete in Constructions²

C 1018 Test Method for Flexural Toughness and First Crack Strength of Fiber-Reinforced Concrete (Using Beam With Third Point Loading)²

3. Terminology

3.1 Definitions of Terms Specific to This Standard:

¹ This specification is under the jurisdiction of ASTM Committee C09 on Concrete and Concrete Aggregates and is the direct responsibility of Subcommittee C09.42 on Fiber-Reinforced Concrete.

Current edition approved Nov. 10, 2001. Published January 2002. Originally published as C 1399-98. Last previous edition C 1399-00.

² *Annual Book of ASTM Standards*, Vol 04.02.

3.1.1 *deflection*—mid-span deflection of the test beam obtained in a manner that excludes deflection caused by the following: (1) the flexural test apparatus, (2) crushing and seating of the beam at support contact points, and (3) torsion of the beam; sometimes termed net deflection.

3.1.2 *initial loading curve*—the load-deflection curve obtained by testing an assembly that includes both the test beam and a specified steel plate (Fig. 1); plotted to a deflection of at least 0.25 mm (0.010 in.) (Fig. 2).

3.1.3 *reloading curve*—the load-deflection curve obtained by reloading and retesting the precracked beam, that is, after the initial loading but without the steel plate. (Fig. 2)

3.1.4 *reloading deflection*—deflection measured during the reloading of the cracked beam and with zero deflection referenced to the start of the reloading.

3.1.5 *residual strength*—the flexural stress on the cracked beam section obtained by calculation using loads obtained from the reloading curve at specified deflection values (see Note 1).

NOTE 1—Residual strength is not a true stress but an engineering stress computed using the flexure formula for linear elastic materials and gross (uncracked) section properties.

3.1.6 *average residual strength*—the average stress-carrying ability of the cracked beam that is obtained by calculation using the residual strength at four specified deflections.

4. Summary of Test Method

4.1 Cast or sawed beams of fiber-reinforced concrete are cracked using the third-point loading apparatus specified in Test Method C 78 modified by a steel plate used to assist in support of the concrete beam during an initial loading cycle (Fig. 1). The steel plate is used to help control the rate of deflection when the beam cracks. After the beam has been cracked in the specified manner, the steel plate is removed and the cracked beam is reloaded to obtain data to plot a reloading load-deflection curve. Load values at specified deflection values on the reloading curve are averaged and used to calculate the average residual strength of the beam.

5. Significance and Use

5.1 This test method provides a quantitative measure useful in the evaluation of the performance of fiber-reinforced concrete. It allows for comparative analysis among beams

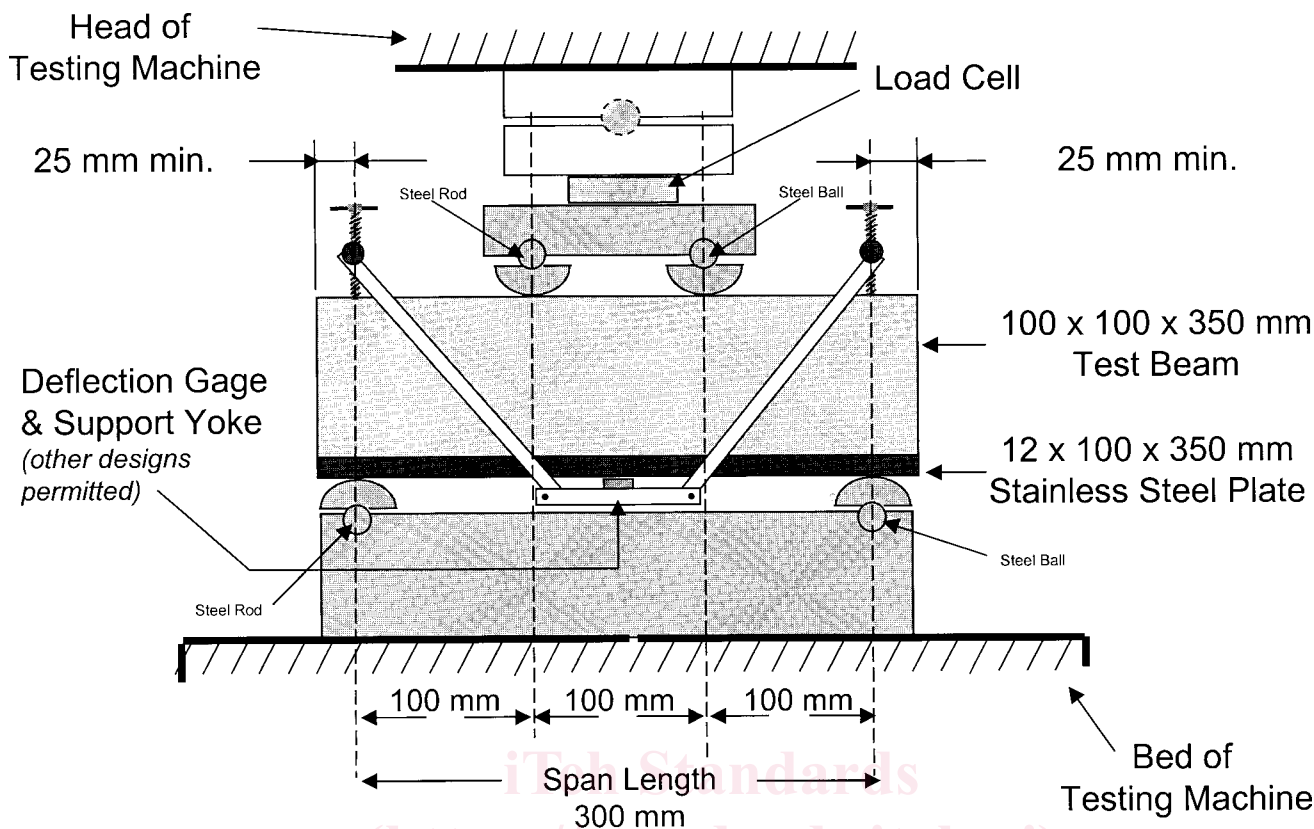

Note: All dimensions are $\pm 2\%$

FIG. 1 Diagrammatic View of a Suitable Apparatus for Residual Strength Test of Fiber-Reinforced Concrete

containing different fiber types, including materials, dimension and shape, and different fiber contents. Results can be used to optimize the proportions of fiber-reinforced concrete mixtures, to determine compliance with construction specifications, to evaluate fiber-reinforced concrete which has been in service, and as a tool for research and development of fiber-reinforced concrete (see Note 2).

NOTE 2—Banthia and Dubey³ compared results using this test method with residual strengths at the same net deflections from Test Method C 1018 on 45 beams with a single fiber configuration at proportions of 0.1, 0.3, and 0.5 % by volume and reported an average 6.4 % lower than Test Method C 1018 test results.

5.2 Test results are intended to reflect either consistency or differences among variables used in proportioning the fiber-reinforced concrete to be tested, including fiber type (material), fiber size and shape, fiber amount, beam preparation (sawed or molded), and beam conditioning.

5.3 In molded beams fiber orientation near molded surfaces will be affected by the process of molding. For tests of fiber-reinforced concrete containing relatively rigid or stiff fibers of length greater than 40 mm (1.5 in.), use of sawed beams cut from samples which had initially a width and depth at least 3 times the length of the fiber is recommended to minimize effects of fiber orientation.

6. Apparatus

6.1 *Either Screw Gear or Hydraulic Testing Apparatus*, with the ability to control the rate of motion of the loading head and meeting the requirements of Test Method C 78. A load cell with a 44.5 kN capacity (10,000 lbf) will generally be required. Closed-loop feed-back controlled deflection apparatus is not required.

6.2 *Flexural-Loading Beam-Support Apparatus*, conforming to the requirements of Test Method C 78.

6.3 *Load and Deflection-Measuring Devices*, such as load cells and electronic transducers, capable of producing electronic analog signals and having support apparatus located and arranged in a manner that provide determination of applied load and mid-span deflection (see 3.1.5) of the beam. Measure deflection using a device capable of measuring net deflection at the beam mid-span with a minimum resolution of 0.025 mm (0.001 in.) by one of the following alternative methods (see Note 3).

NOTE 3—The deflection measurement requires care in the arrangement of displacement transducers in order to minimize extraneous contributions such as might be caused by seating or twisting of the specimen. A suggested method to accomplish this measurement uses a spring-loaded electronic displacement transducer mounted on a suspension yoke as is shown in Fig. 1.

6.3.1 *Three Electronic Transducers*, mounted on a support frame. The support frame positions the transducers along the centerline of the top surface of the test beam at locations so as to contact the beam at midspan and each support location.

³ Banthia, N. and Dubey, A., "Measurement of Flexural Toughness of Fiber Reinforced Concrete Using a Novel Technique, Part I: Assessment and Calibration," In Press, *Materials Journal*, American Concrete Institute.