



SLOVENSKI STANDARD
SIST ISO 6947:1995

01-november-1995

Zvari - Položaji pri varjenju - Opredelitve kotov nagibov in vrtenja

Welds -- Working positions -- Definitions of angles of slope and rotation

Soudures -- Positions de travail -- Définitions des angles d'inclinaison et de rotation

Ta slovenski standard je istoveten z: ISO 6947:1990

[SIST ISO 6947:1995](https://standards.iteh.ai/catalog/standards/sist/e8603b84-2c7a-4209-aa45-cb8f69811a4f/sist-iso-6947-1995)

<https://standards.iteh.ai/catalog/standards/sist/e8603b84-2c7a-4209-aa45-cb8f69811a4f/sist-iso-6947-1995>

ICS:

25.160.40 Varjeni spoji in vari Welded joints

SIST ISO 6947:1995

en

iTeh STANDARD PREVIEW
(standards.iteh.ai)

SIST ISO 6947:1995

<https://standards.iteh.ai/catalog/standards/sist/e8603b84-2c7a-4209-aa45-cb8f69811a4f/sist-iso-6947-1995>

INTERNATIONAL STANDARD

ISO 6947

Second edition
1990-02-01

Corrected and reprinted
1993-05-01

Welds — Working positions — Definitions of angles of slope and rotation

(Revision of ISO 6947 : 1980)

iTeh STANDARD PREVIEW

*Soudures — Positions de travail — Définitions des angles d'inclinaison et de
rotation*
(standards.iteh.ai)

[SIST ISO 6947:1995](https://standards.iteh.ai/catalog/standards/sist/e8603b84-2c7a-4209-aa45-cb8f69811a4f/sist-iso-6947-1995)

[https://standards.iteh.ai/catalog/standards/sist/e8603b84-2c7a-4209-aa45-
cb8f69811a4f/sist-iso-6947-1995](https://standards.iteh.ai/catalog/standards/sist/e8603b84-2c7a-4209-aa45-cb8f69811a4f/sist-iso-6947-1995)



Reference number
ISO 6947 : 1990 (E)

ISO 6947 : 1990 (E)

Foreword

ISO (the International Organization for Standardization) is a worldwide federation of national standards bodies (ISO member bodies). The work of preparing International Standards is normally carried out through ISO technical committees. Each member body interested in a subject for which a technical committee has been established has the right to be represented on that committee. International organizations, governmental and non-governmental, in liaison with ISO, also take part in the work. ISO collaborates closely with the International Electrotechnical Commission (IEC) on all matters of electrotechnical standardization.

Draft International Standards adopted by the technical committees are circulated to the member bodies for approval before their acceptance as International Standards by the ISO Council. They are approved in accordance with ISO procedures requiring at least 75 % approval by the member bodies voting.

International Standard ISO 6947 was prepared by Technical Committee ISO/TC 44, *Welding and allied processes*.

SIST ISO 6947:1995

This second edition cancels and replaces the first edition (ISO 6947:1980), of which it constitutes a technical revision; reasons for the revision are given in the "Introduction" (p. iii).

© ISO 1990

All rights reserved. No part of this publication may be reproduced or utilized in any form or by any means, electronic or mechanical, including photocopying and microfilm, without permission in writing from the publisher.

International Organization for Standardization
Case postale 56 • CH-1211 Genève 20 • Switzerland

Printed in Switzerland

Introduction

The main reasons for the revision of ISO 6947 : 1980 are given below.

The working positions should be valid for welds in plates and pipes.

The direction of welding is an essential parameter for determining the working position, e.g. up or down; however, in ISO 6947 : 1980, the working direction was not dealt with.

The working position is not dependent on the geometrical arrangement of the joint, e.g. butt or fillet joint, or that of the semi-finished product.

iTeh STANDARD PREVIEW
The limitations for slope (within 0° to 90°) and for rotation (up to a maximum of 180°), as specified in ISO 6947 : 1980 (clockwise or counter-clockwise), prevent the complete specification of the weld and the direction of welding in space; it could not, therefore, be applicable for automatic and robotic welding. It is intended in this second edition of ISO 6947 that the whole sphere be included so that welds in all types and all directions are covered.
<https://standards.iteh.ai/catalog/standards/sist/e8603b84-2c7a-4209-aa45-cb8f69811a4f/sist-iso-6947-1995>

To avoid any misunderstanding, the main positions have been given symbols which can easily be used for designation purposes; these symbols were chosen independently of possible meaningful abbreviations, i.e. they are not derived from any particular language.

The centreline is normally identical with the position of the stick electrode. The main positions have been defined without any tolerances for slope and rotation. For some stick electrodes, it may be useful to add the required tolerances as necessary for their application. In such cases, the main position, e.g. flat position, can be supplemented by specifying limits of slope and rotation.

iTeh STANDARD PREVIEW
(standards.iteh.ai)

This page intentionally left blank

SIST ISO 6947:1995

<https://standards.iteh.ai/catalog/standards/sist/e8603b84-2c7a-4209-aa45-cb8f69811a4f/sist-iso-6947-1995>

Welds — Working positions — Definitions of angles of slope and rotation

1 Scope

This International Standard defines working positions and makes it possible to locate welds in space with reference to the horizontal reference plane (usually parallel to the workshop floor) by means of angles of slope and rotation which are independent from surrounding construction.

2 Definitions

For the purposes of this International Standard, the following definitions apply.

2.1 working position: Position determined by the position of the weld in space and by the working direction.

2.2 slope, S : In the case of straight welds, the angle between the root line and the positive x -axis of the horizontal reference plane (see figure 1); the slope is measured in the mathematically positive (i.e. counter-clockwise) direction.

The co-ordinate system shall be arranged so that the root line lies in the vertical reference plane (x/z -plane; see figure 1) and that the working direction radiates outwards from the co-ordinate origin.

In the case of curved welds, the same stipulation applies: the slope is obtained from the tangent to the root line — at the particular cross-section of the weld in question — and the x -axis.

Each particular cross-section has its own specific co-ordinate system.

NOTE For pipes with inclined axes, the slope is intrinsically expressed by the welding direction (see 3.2).

2.3 rotation, R : The angle between the centreline of the weld (i.e. the line joining the centres of the weld root and the capping layer) and the positive y -axis or a line parallel to the y -axis, measured in the mathematically positive (i.e. counter-clockwise) direction in the plane of the transverse cross-section of the weld in question.

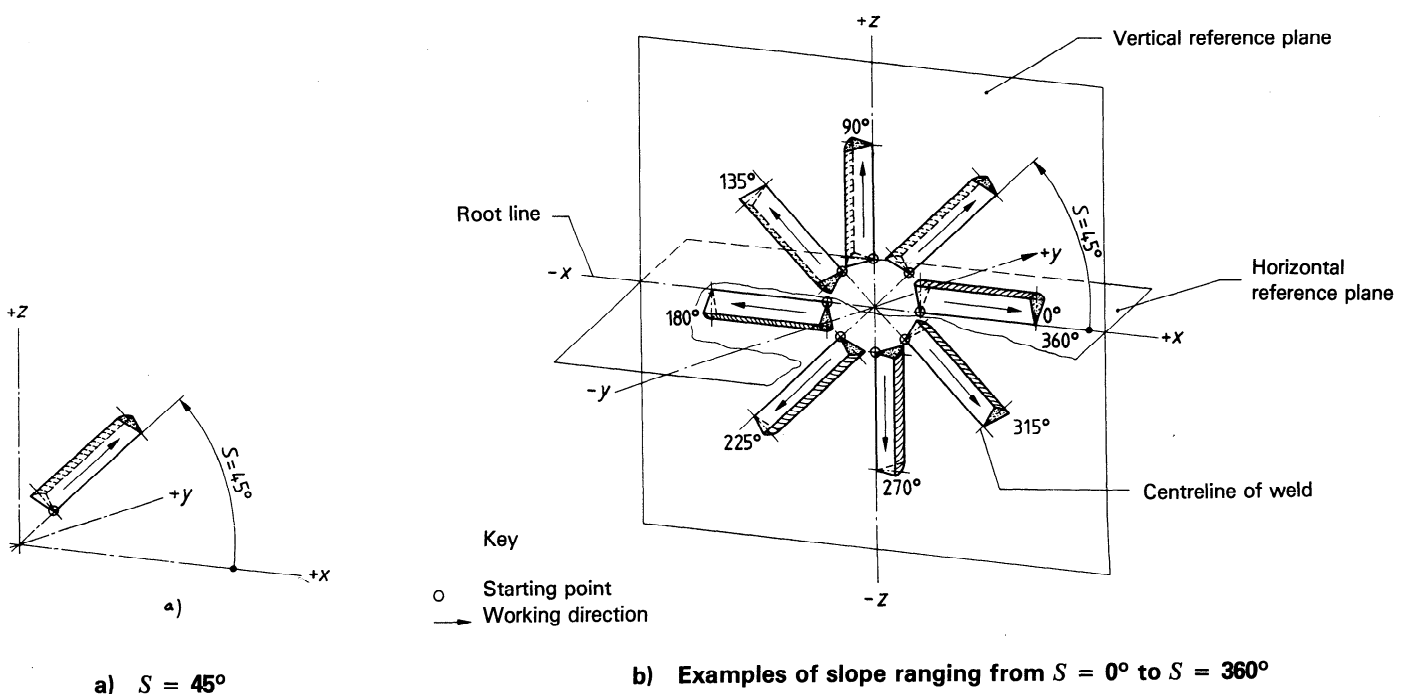

Figure 1 — Slope, S

ISO 6947 : 1990 (E)

The viewing direction for the weld cross-section is directed towards the co-ordinate origin, i.e. opposite to the working direction (see figure 2).

In the case of slopes where $S = 90^\circ$ or $S = 270^\circ$ (see figure 1), it is not necessary to determine the rotation because all angles may occur. Examples of how rotation is determined on symmetrical and asymmetrical butt and fillet welds are given in figures 3 to 5.

NOTES

- 1 The centreline usually coincides with the position of the filler material, e.g. covered electrode.
- 2 For pipes with inclined axes, the rotation is intrinsically expressed by the angle of inclination (see 3.3).

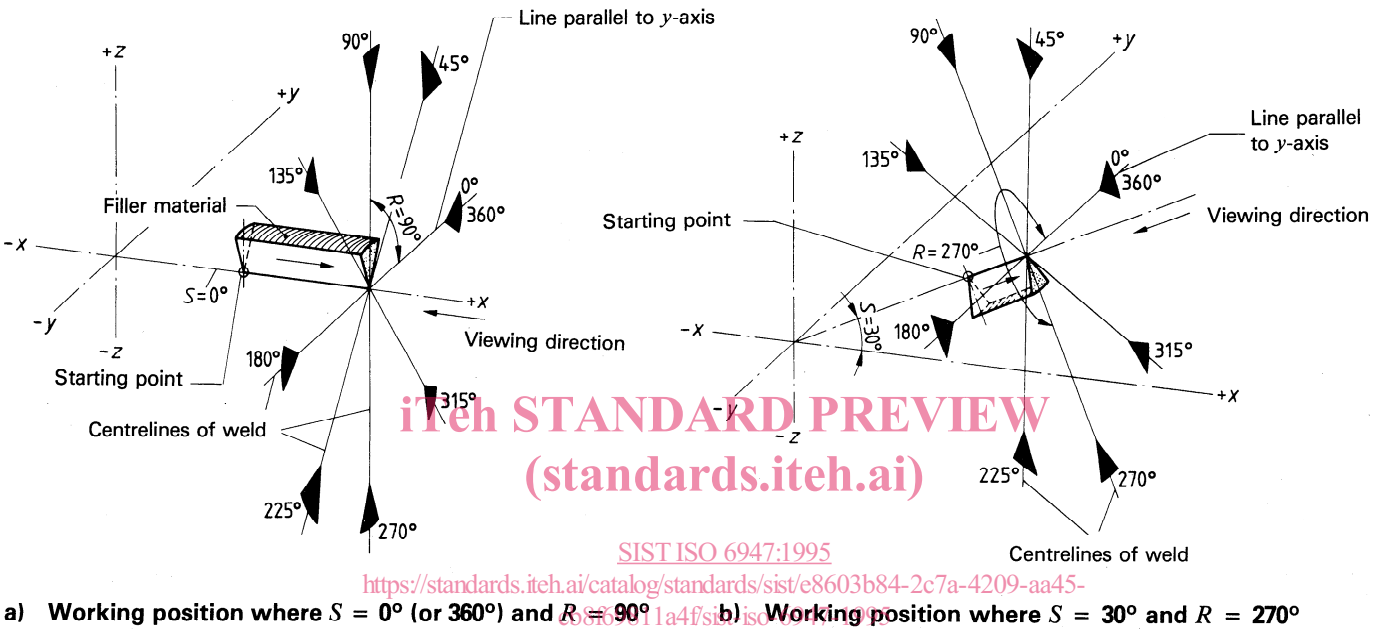

Figure 2 – Rotation R

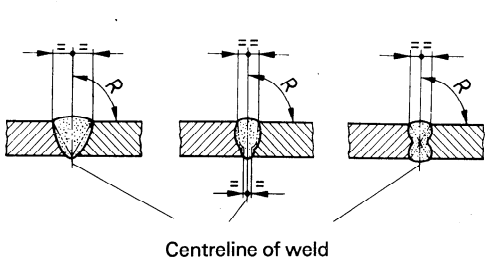

Figure 3 – Examples of rotation ($R = 90^\circ$) of symmetrical butt welds with horizontal workpiece surface

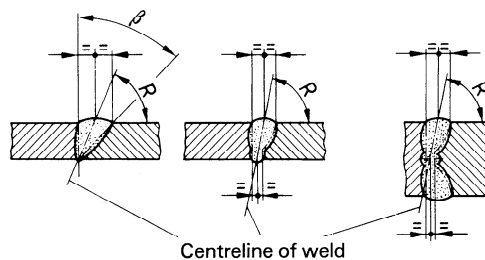

Figure 4 – Examples of rotation, R , of asymmetrical butt welds with horizontal workpiece surface

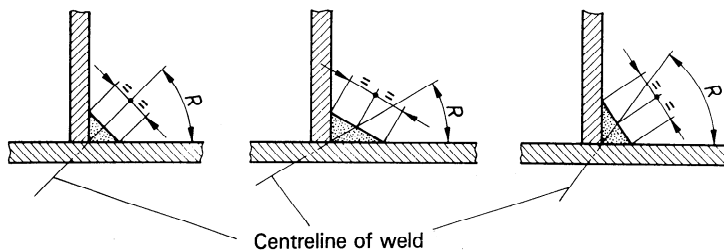

Figure 5 – Examples of rotation, R , of symmetrical and asymmetrical fillet welds

3 Working positions

3.1 Main positions

The main positions, defined by slope and rotation, are given in table 1 and illustrated in figure 6. For the sake of clarity, symbols for the main working positions are given from the co-ordinate origin; the working direction is outwards.

Examples of main positions for butt and fillet welds are illustrated in figure 7.

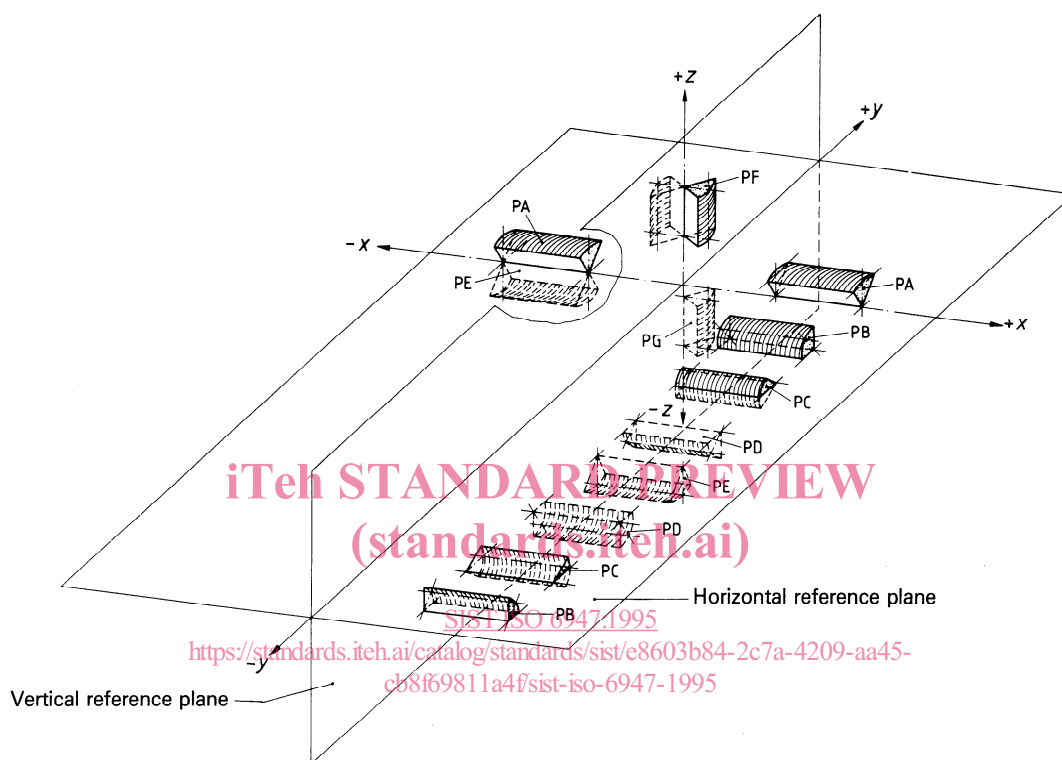

a) Schematic diagram

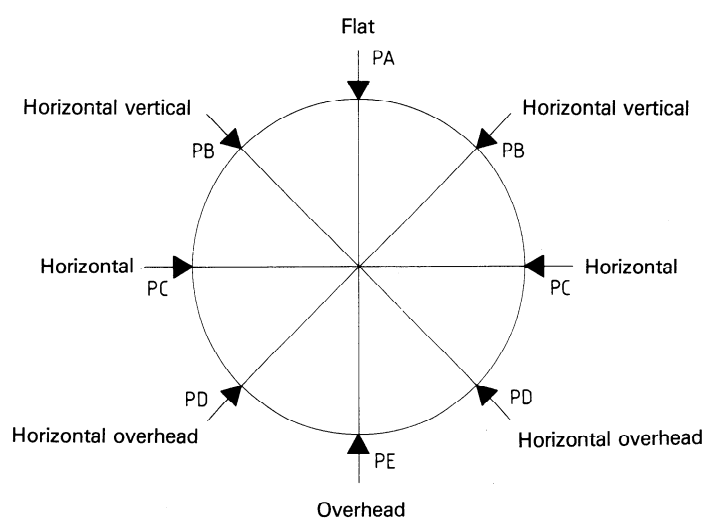

b) Simplified view

Figure 6 — Main positions