



Designation: D 6333 – 98

## Standard Practice for Collection of Dislodgeable Pesticide Residues from Floors<sup>1</sup>

This standard is issued under the fixed designation D 6333; the number immediately following the designation indicates the year of original adoption or, in the case of revision, the year of last revision. A number in parentheses indicates the year of last reappraisal. A superscript epsilon ( $\epsilon$ ) indicates an editorial change since the last revision or reappraisal.

### 1. Scope

1.1 This practice covers a procedure for collection of dislodgeable pesticide residues from indoor floor surfaces.

1.2 This practice and the sampling methodology described are applicable to bare floors or covered floor surfaces, for example, carpeting and vinyl flooring.

1.3 This practice and the sampling methodology described are applicable to all pesticides listed in Practice D 4861 whether applied directly to the floor surface or transported there by migration within the room or tracked in from outdoors.

1.4 Floor surfaces for which this practice has been successfully applied include nylon plush carpeting, polypropylene level-loop carpeting, and vinyl flooring.

1.5 Sample analysis will be dependent upon the nature of the pesticides targeted and is beyond the scope of this practice; however, the analytical procedures discussed in Practice D 4861 are applicable to this practice.

1.6 The values stated in SI units are to be regarded as the standard.

1.7 *This standard does not purport to address all of the safety concerns, if any, associated with its use. It is the responsibility of the user of this standard to establish appropriate safety and health practices and determine the applicability of regulatory limitations prior to its use.*

### 2. Referenced Documents

#### 2.1 ASTM Standards:

D 1193 Specification for Reagent Water<sup>2</sup>

D 1356 Terminology Relating to Sampling and Analysis of Atmospheres<sup>3</sup>

D 4861 Practice for Sampling and Selection of Analytical Techniques for Pesticides and Polychlorinated Biphenyls in Air<sup>3</sup>

E 1 Specification for ASTM Thermometers<sup>4</sup>

<sup>1</sup> This practice is under the jurisdiction of ASTM Committee D-22 on Sampling and Analysis of Atmospheres and is the direct responsibility of Subcommittee D22.05 on Indoor Air.

Current edition approved Oct. 10, 1998. Published January 1999.

<sup>2</sup> *Annual Book of ASTM Standards*, Vol 11.01.

<sup>3</sup> *Annual Book of ASTM Standards*, Vol 11.03.

<sup>4</sup> *Annual Book of ASTM Standards*, Vol 14.03.

E 337 Test Method for Measuring Humidity with a Psychrometer (the Measurement of Wet-Bulb and Dry-Bulb Temperatures)<sup>3</sup>

### 3. Terminology

3.1 *Definitions*—For definitions of terms used in this practice, refer to Terminology D 1356.

3.1.1 *dislodgeable residue*—that part of the residue of a chemical deposited on a solid surface that may be transferred by direct contact to human skin or clothing.

3.1.2 *sampling traverse*—the distance from the starting point to the end point over which the sampling media contacts the floor surface for collection of a single sample.

3.1.3 *transfer coefficient*—the ratio of the amount of pesticide residue collected by the sampling media to the area of the surface contacted by the media during a single sampling traverse.

3.1.4 *transfer efficiency*—the ratio of the transfer coefficient to the pesticide surface loading determined by analysis of deposition coupons placed strategically on the test surface before the pesticide application.

### 4. Summary of Practice

4.1 The sampling method described in this practice is taken from published work **(1,2,3,4)**<sup>5</sup>.

4.2 Dislodgeable pesticide residues from floor surfaces are collected by transfer to an annular ring of polyurethane foam (PUF), which is rolled across the floor at a constant speed and applied pressure.

4.3 The PUF sampling ring is slipped over a cylindrical metal axle that functions as the front wheel of the PUF roller apparatus. The apparatus is typically constructed of aluminum and consists of a frame with two permanent rear wheels and the detachable axle cylinder on the front.

4.4 Weights are attached to the roller frame to apply the desired downward force on the PUF roller ring (sampling pressure). A total weight of 3.88 kg provides a sampling pressure of 8300 Pa, corresponding approximately to that of a 9 kg child crawling or walking.

<sup>5</sup> The boldface numbers in parentheses refer to the list of references at the end of this standard.

4.5 A handle is connected at the rear of the roller frame to push or pull the device across the floor surface.

4.6 A template or similar measuring device is used to identify the area to be sampled. The axle cylinder is fitted with a clean PUF ring, and the roller is then pushed at a constant rate of approximately 10 cm/s over a distance of 1.0 m and then immediately pulled in the reverse direction back over the same sampling area at the same rate of speed, ending at the original starting position.

4.7 The PUF ring is removed from the detached axle cylinder and placed in a sealed container for transport to the laboratory for analysis.

4.8 The PUF ring is extracted and analyzed using specific analytical procedures for the pesticides of interest. Typical methods involve Soxhlet extraction with analysis of extracts by gas chromatography/mass spectrometry (GC/MS), gas chromatography/electron capture detection (GC/ECD), or other techniques noted in Practice D 4861.

**5. Significance and Use**

5.1 This practice may be used to estimate the potential for human exposure to pesticide residues that may be dislodged from residential floor surfaces by dermal contact. The sampling device employed is designed to approximately replicate the pressure applied by a 9 kg child crawling or walking on the floor.

5.2 Laboratory tests and field studies have shown that the transfer coefficient of the sampling device for collection of dried pesticide residues from nylon plush carpets is two to three times higher than that of a dry hand (palm only) pressed ten times at 7300 Pa over the same area of carpet (2,4,5).

5.3 This practice has been found suitable for use on plush and level loop carpets and vinyl flooring (2, 3).

5.4 This practice does not describe procedures for evaluation of the safety of floor surfaces or the potential for human

exposure to dislodgeable pesticide residues. It is the user's responsibility to evaluate the data collected by this practice and make such determinations in the light of other available information.

**6. Interferences**

6.1 There are no known interferences to the collection of dislodgeable pesticide residues from floors using this practice. The presence of excessive moisture levels in carpeting, as may be the case shortly after a wet cleaning operation, may affect the dislodgeability of residues, possibly yielding higher than normal results.

6.2 Analytical interferences may be caused by contaminants in the sampling medium, solvents, and reagents and on glassware and other sampling or sample processing hardware that result in discrete artifacts and elevated baselines, or both, in the detector profiles. For potential analytical interferences, refer to Practice D 4861.

**7. Apparatus**

7.1 *PUF Roller Sampler*, (as shown in Fig. 1) may be constructed by a machinist using primarily aluminum materials. The typical apparatus consists of a frame (12.4 by 25.4 cm) that is attached to a rear axle that holds a swivel joint in the center for attaching the handle and has two aluminum wheels (2.5-cm wide by 10.2-cm diameter). The distance between the outside of the two wheels is 21.6 cm and between the inside of the wheels is 16.5 cm. An aluminum cylinder (7.6-cm long by 4.3-cm diameter) is attached to the front of the sampler frame by 6-mm diameter hex head axle bolts on the cylinder that fit into slots on the frame. This cylinder serves as the front axle and also holds the PUF sampling medium (see 7.2). The front axle cylinder is secured in the slots by spring steel retaining clips that permit easy attachment and removal of the cylinder. The handle for the sampler is two pieces that screw together

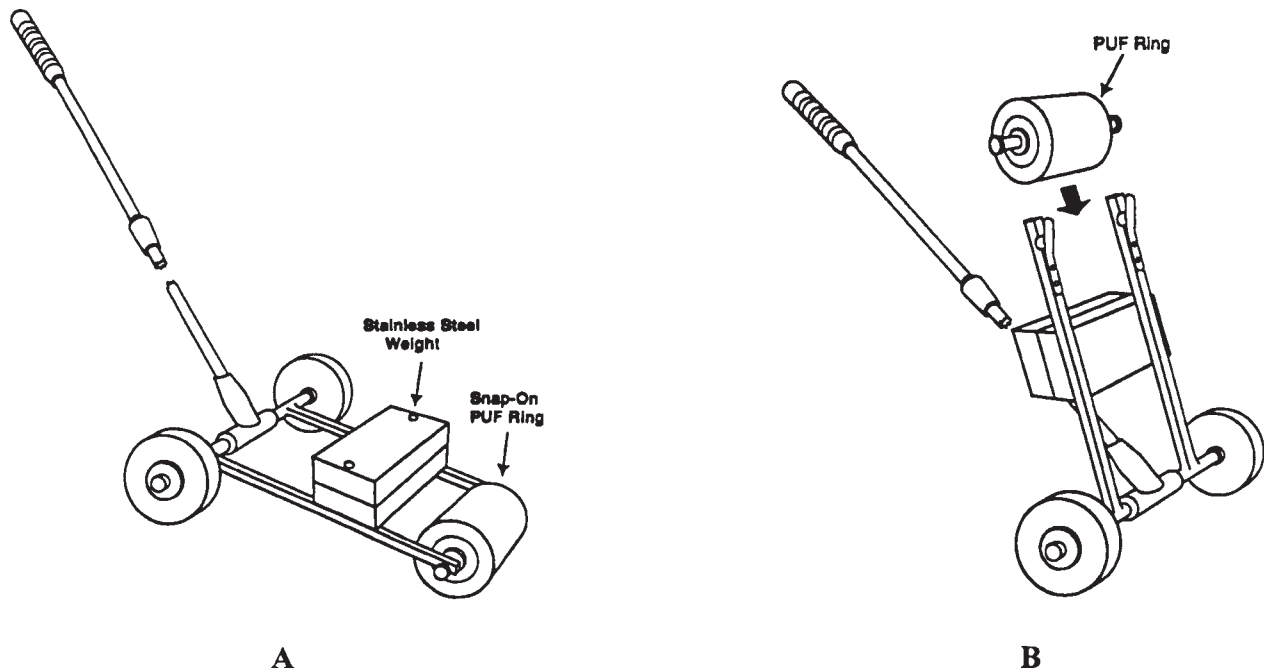

FIG. 1 PUF Roller: A. In Position for Sampling. B. Axle Cylinder/Frame Assembly.

(102-cm long by 1.3-cm diameter, overall) and then screw into the swivel joint on the rear axle. Two stainless steel blocks, each measuring 12.7 by 7.3 by 2.5 cm and having a combined weight of 3.88 kg, are attached to the center of the frame through holes that fit over 3-mm diameter threaded posts on either side of the frame. The weights are secured to the frame with hand-tightened knurled nuts.

**NOTE 1**—Although the use of stainless steel to construct the weights is not required (other materials of similar density will suffice), the ease of cleaning and resistance to corrosion make this metal very useful.

**7.2 PUF Sampling Medium**—The sampling medium consists of an annular plug cut from a sheet of medium density (0.029 g/cm<sup>3</sup>) open-cell, polyether-type polyurethane foam, 7.6-cm thick.

**NOTE 2**—This foam is the type used commercially in upholstery and is widely used for air sampling. It is the same type as that described in Practice D 4861, but has a higher density.

**7.2.1** Cut the foam sheet stock with a high-speed cutting die lubricated with distilled water to produce an annular ring 8.9-cm O.D. by 4.2-cm I.D. Alternatively, the PUF sheet stock may be immersed in distilled water and compressed to achieve saturation prior to cutting.

**7.2.2** After cutting, immerse the rings in pesticide grade acetone and compress to remove most of the distilled water. Repeat the process.

**7.2.3** Extract the rings with acetone in a Soxhlet extractor for 24 h at 4 to 6 cycles/h, followed by a second extraction with 5 % diethyl ether in *n*-hexane for an additional 14 to 24 h at 4 to 6 cycles/h. A final 24-h extraction with acetone is recommended to ensure that the PUF ring retains its shape.

**7.2.4** Upon completion of the Soxhlet extractions, transfer the PUF rings with solvent-rinsed tweezers into an open, pre-cleaned container (Refer to Practice D 4861 for cleaning).

**7.2.5** Place containers with PUF rings inside a vacuum drying oven and dry for 16 h under purified zero grade nitrogen.

**7.2.6** Place the dried rings in clean, sealed containers for storage, preferably in an area protected from prolonged exposure to light.

**7.3 Guide Bar**—A flat bar or ruler approximately 1.4-m long can be used to guide the sampler during a traverse over the floor surface. For example, an aluminum bar 2.5-cm wide and 6-mm thick may be used in this application. The bar is clearly marked at the starting point and at 10-cm intervals along its length up to and including the ending point at the 1.0-m mark. The starting point is marked on the bar about 34 cm from one end so that the wheels of the sampler will contact the bar when the front of the sampler is in place to begin a sampling traverse.

**7.3.1** Alternatively, a template may be constructed to serve as a guide for sampling. An example of such a template that has been found useful may be constructed from two 168-cm long right-angled side bars made from extruded aluminum or other suitable material with each side of the L-shaped bar having a width of about 2.5 cm. The two angled sidebars are connected at each end with a 2.5-cm wide flat bar that is 21.5-cm long, thereby resulting in two tracks that will accommodate the rear wheels of the PUF roller with only a slight tolerance. The thickness of the side and end bars is approximately 0.3 cm. The

vertical height of the side bars should be sufficient to keep the wheels on the track, for example 2.5 cm. The carpet surface is exposed through a central opening 163 by 16.5 cm in dimension. The template is clearly marked at the starting point and at 10-cm intervals along its length up to and including the ending point at the 1.0-m mark. The starting point is marked on the template about 34 cm from one end so that the wheels of the sampler will remain upon the tracks with some room to spare when the front of the sampler is in position to begin a sample traverse.

**7.4 Starting Platform**—A thin (1.6-mm) aluminum sheet (33 by 25.4 cm) to be used as a platform to prevent contact of the PUF ring with the surface to be sampled before starting a sampling traverse.

**7.5 Other Equipment:**

**7.5.1 Tongs**, large (23-cm long), scissor type, stainless steel tongs, or similar implements, for installing and removing the PUF rings from the sampler apparatus.

**7.5.2 Gloves**—Protective gloves, latex and powder free, are required to guard against potentially hazardous exposures and to minimize risk of cross contamination between sampler apparatus and sampling media.

**7.5.3 Squeeze Bottle**—A plastic (polytetrafluoroethylene) squeeze bottle, 250–500-mL volume, is filled with solvent and is used to rinse the sampler apparatus that contacts the sampling media and the tongs used to install and remove the media.

**7.5.4 Stopwatch.**

**7.5.5 Clean Glass Jars**, for the collection and storage of samples.

**7.5.6 Thermometer** (see Specification E 1).

**7.5.7 Relative Humidity Meter** (see Test Method E 337).

## 8. Reagents

**8.1 Acetone**, pesticide quality.

**8.2 *n*-Hexane**, pesticide quality.

**8.3 Diethyl Ether**, analytical reagent grade, preserved with 2 % ethanol.

**8.4 2-Propanol**, pesticide quality.

**8.5 Purity of Reagents**—Reagent grade chemicals shall be used in all tests. Unless otherwise indicated, it is intended that all reagents shall conform to the specifications of the Committee on Analytical Reagents of the American Chemical Society, where such specifications are available.<sup>6</sup>

**8.6 Purity of Water**—References to distilled water shall be understood to mean distilled water, which is Type II reagent water conforming to Specification D 1193.

## 9. Sampling Procedure

**9.1 Sampling Layout:**

**9.1.1** At least three samples should be collected in the room to be monitored. Unless the monitoring protocol requires

<sup>6</sup> *Reagent Chemicals, American Chemical Society Specifications*, American Chemical Society, Washington, DC. For suggestions on the testing of reagents not listed by the American Chemical Society, see *Analar Standards for Laboratory Chemicals*, BDH Ltd., Poole, Dorset, U.K., and the *United States Pharmacopeia and National Formulary*, U.S. Pharmacopeil Convention, Inc. (USPC), Rockville, MD.