

# INTERNATIONAL STANDARD

# ISO 6953-1

First edition  
1990-01-15

---

---

## Pneumatic fluid power — Air line pressure regulators —

### Part 1:

Main characteristics to be included in commercial  
literature and specific requirements

(standards.iteh.ai)

*Transmissions pneumatiques — Réducteurs de pression pour air comprimé —*

*Partie 1: Principales caractéristiques à inclure dans la documentation commerciale et  
exigences particulières*

<https://standards.iteh.ai/catalog/standards/sist/434dce06-fdaa-44ed-a54e-ddcba0909956/iso-6953-1-1990>



Reference number  
ISO 6953-1 : 1990 (E)

## Foreword

ISO (the International Organization for Standardization) is a worldwide federation of national standards bodies (ISO member bodies). The work of preparing International Standards is normally carried out through ISO technical committees. Each member body interested in a subject for which a technical committee has been established has the right to be represented on that committee. International organizations, governmental and non-governmental, in liaison with ISO, also take part in the work. ISO collaborates closely with the International Electrotechnical Commission (IEC) on all matters of electrotechnical standardization.

Draft International Standards adopted by the technical committees are circulated to the member bodies for approval before their acceptance as International Standards by the ISO Council. They are approved in accordance with ISO procedures requiring at least 75 % approval by the member bodies voting.

International Standard ISO 6953-1 was prepared by Technical Committee ISO/TC 131, *Fluid power systems*.

ISO 6953-1:1990

ISO 6953 will consist of the following parts, under the general title *Pneumatic fluid power — Air line pressure regulators*:

- *Part 1: Main characteristics to be included in commercial literature and specific requirements*
- *Part 2: Specifications for test installations and type test procedure*

© ISO 1990

All rights reserved. No part of this publication may be reproduced or utilized in any form or by any means, electronic or mechanical, including photocopying and microfilm, without permission in writing from the publisher.

International Organization for Standardization  
Case postale 56 • CH-1211 Genève 20 • Switzerland

Printed in Switzerland

## Introduction

In pneumatic fluid power systems, power is transmitted and controlled through air under pressure within a circuit. Air line pressure regulators maintain a constant pressure selected to ensure optimum performance of the installation.

## iTeh STANDARD PREVIEW (standards.iteh.ai)

ISO 6953-1:1990

<https://standards.iteh.ai/catalog/standards/sist/434dce06-fdaa-44ed-a54e-ddcba0909956/iso-6953-1-1990>

**iTeh STANDARD PREVIEW**  
**(standards.iteh.ai)**

This page intentionally left blank

ISO 6953-1:1990

<https://standards.iteh.ai/catalog/standards/sist/434dce06-fdaa-44ed-a54e-ddcba0909956/iso-6953-1-1990>

# Pneumatic fluid power — Air line pressure regulators —

## Part 1 : Main characteristics to be included in commercial literature and specific requirements

### 1 Scope

This part of ISO 6953 specifies which characteristics of air line pressure regulators, required by manufacturers and users of pneumatic fluid power systems, are to be included in the manufacturers' literature.

It also specifies some requirements which the regulators must meet.

### 2 Normative references

The following standards contain provisions which, through reference in this text, constitute provisions of this part of ISO 6953. At the time of publication, the editions indicated were valid. All standards are subject to revision, and parties to agreements based on this part of ISO 6953 are encouraged to investigate the possibility of applying the most recent editions of the standards listed below. Members of IEC and ISO maintain registers of currently valid International Standards.

ISO 7-1 : 1982, *Pipe threads where pressure-tight joint are made on the threads — Part 1 : Designation, dimensions and tolerances.*

ISO 228-1 : 1982, *Pipe threads where pressure-tight joints are not made on the threads — Part 1 : Designation, dimensions and tolerances.*

ISO 2944 : 1974, *Fluid power systems and components — Nominal pressures.*

ISO 5598 : 1985, *Fluid power systems and components — Vocabulary.*

ISO 8778 : —<sup>1)</sup>, *Pneumatic fluid power — Standard reference atmosphere.*

### 3 Definitions

For the purposes of this part of ISO 6953, the definitions given in ISO 5598, together with the following, apply.

**3.1 air line pressure regulator** : Device designed to maintain the compressed air pressure approximately constant within an enclosed circuit despite the variation in the operating flow rate and in the inlet pressure.

**3.2 relieving pressure regulator** : Pressure regulator equipped with an unloading device to prevent the outlet pressure from exceeding the original setting.

### 4 Technical requirements

Descriptive literature covering air line pressure regulators shall include the following characteristics.

#### 4.1 General characteristics

##### 4.1.1 General dimensions

The dimensions shown on figure 1 shall be given, in millimetres. For ports, see 4.1.2.

##### 4.1.2 Port sizes

Port sizes should be selected from ISO 228-1 for ports with gas pipe parallel threads, or ISO 7-1 for ports with gas pipe conical threads.

##### 4.1.3 Operating pressures

Air line pressure regulators shall be classified according to their maximum inlet pressure, selected from ISO 2944.

#### EXAMPLE

0,25 MPa ( 2,5 bar)  
0,4 MPa ( 4 bar)  
0,63 MPa ( 6,3 bar)  
1 MPa (10 bar)  
1,6 MPa (16 bar)  
2,5 MPa (25 bar)

1) To be published.

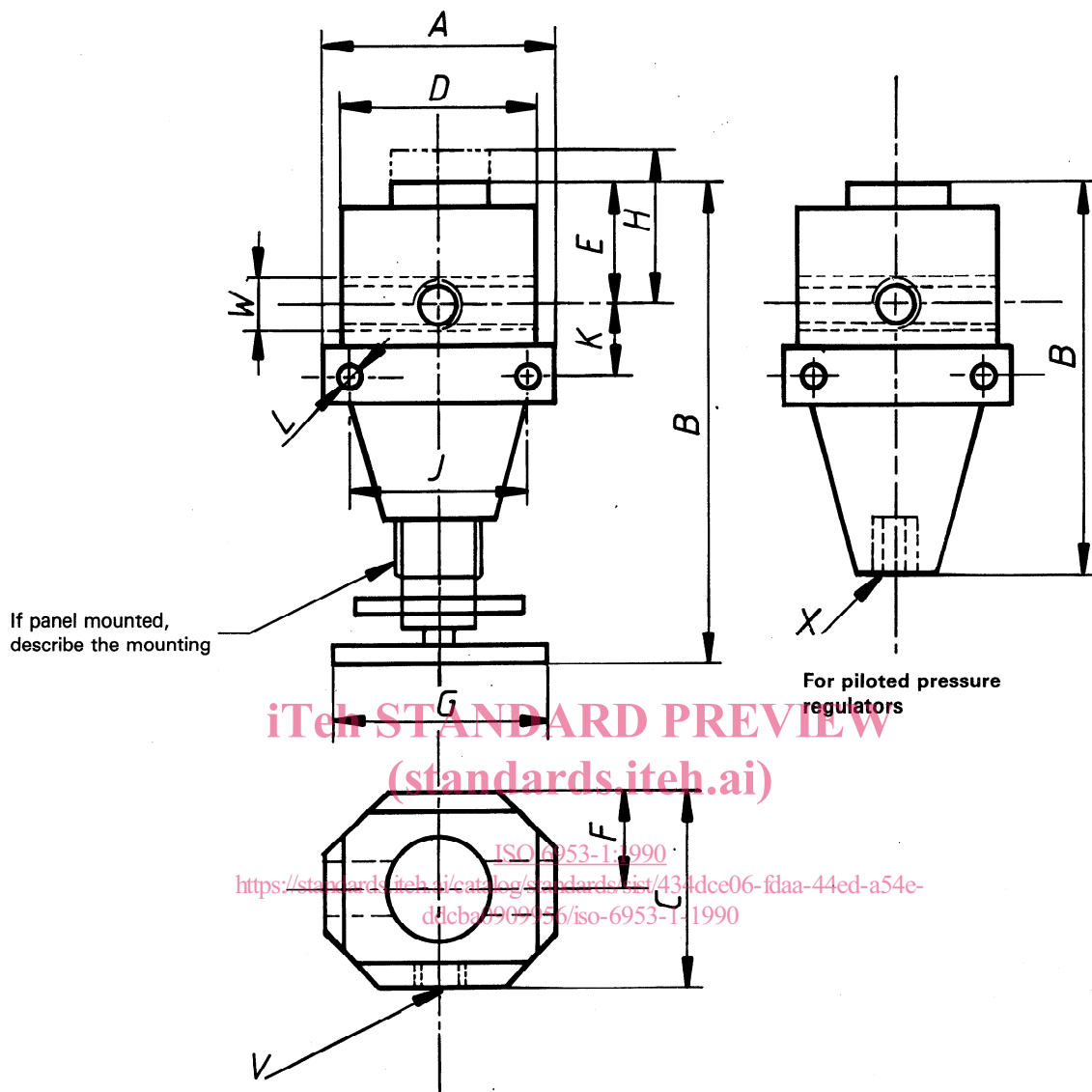

**Key**

- A* = installation length
- B* = maximum installation height
- C* = installation depth, excluding pressure gauge
- D* = distance between the faces of the compressed air connection (inlet/outlet)
- E* = maximum height above the port centreline
- F* = maximum installation depth from the port centreline
- G* = maximum dimension of regulating device
- H* = minimum clearance from the port centreline to permit dismantling
- J*<sup>1)</sup> = distance between mounting holes
- K*<sup>1)</sup> = distance between the port centreline and mounting holes
- L*<sup>1)</sup> = minimum diameter and length of mounting holes or recommended mounting bolts
- V* = pressure gauge port description
- W* = port description
- X* = pilot port description

**Figure 1 – Dimensions of air line pressure regulators**

1) Dimensions *J*, *K* and *L* shall be indicated only if the device has provisions for mounting.

**4.1.4 Range of operating temperatures**

**4.1.4.1** The temperature range in which the material and the operation of the pressure regulator are not impaired shall be stated.

**4.1.4.2** If required, a derating coefficient to be applied to the operating pressure as a function of the operating temperature shall be included.

**4.1.5 Proof pressure**

The complete unit shall be so constructed that it will withstand, without damage or permanent deformation of any component, a proof pressure of 1,5 times the rated maximum operating pressure at the rated maximum operating temperature. This does not imply that the unit is safe for use at a pressure greater than the operating pressure (see 4.1.3).

**4.2 Particular requirements**

The data supplied by the manufacturer shall assist the user in selecting the air line pressure regulator which is best suited for the particular application.

**4.2.1 Outlet or secondary pressure**

The outlet pressure shall always be less than the inlet pressure in order to obtain an approximately constant regulated pressure. The outlet pressure should be chosen as a function of the inlet pressure in the following adjustment range.

Outlet pressure

- 0 to 0,025 MPa ( 0,25 bar)
- 0 to 0,063 MPa ( 0,63 bar)
- 0 to 0,1 MPa ( 1 bar)
- 0 to 0,25 MPa ( 2,5 bar)
- 0 to 0,4 MPa ( 4 bar)
- 0 to 0,63 MPa ( 6,3 bar)
- 0 to 1 MPa (10 bar)
- 0 to 1,6 MPa (16 bar)
- 0 to 2,5 MPa (25 bar)

If required, other pressures should be chosen in accordance with ISO 2944.

**4.2.2 Flow characteristics**

**4.2.2.1** The air flow rate shall be indicated by curves showing the air flow rate *versus* outlet pressure for a given inlet pressure, taking account of the various adjustment settings of outlet pressures as offered by the device considered.

For example : 0,063 — 0,25 — 0,4 MPa (0,63 — 2,5 — 4 bar) for an inlet pressure of 0,63 MPa (6,3 bar).

Graphs shall be presented as shown on figure 2.

**4.2.2.2** For a given inlet pressure, the air flow rate for at least three adjustment settings of the outlet pressure shall be indicated.

**4.2.3 Regulation characteristics**

**4.2.3.1** For a given constant flow rate, curves indicating the variation of the outlet pressure in relation to the variation of the inlet pressure shall be plotted.

The curves shall be plotted for the same outlet pressures as used in 4.2.2.2, and as shown on figure 3.

**4.2.4 Flow characteristics of the relief device**

**4.2.4.1** For pressure regulators incorporating relief devices, for a given outlet pressure, the value of the overpressure causing the relief flow shall be indicated and the relation of the outlet pressure to the relief flow rate shall be plotted on a curve.

**4.2.4.2** The curves shall be plotted for the same outlet pressures as used in 4.2.2.2, and as shown on figure 4. The inlet pressure shall also be stated.

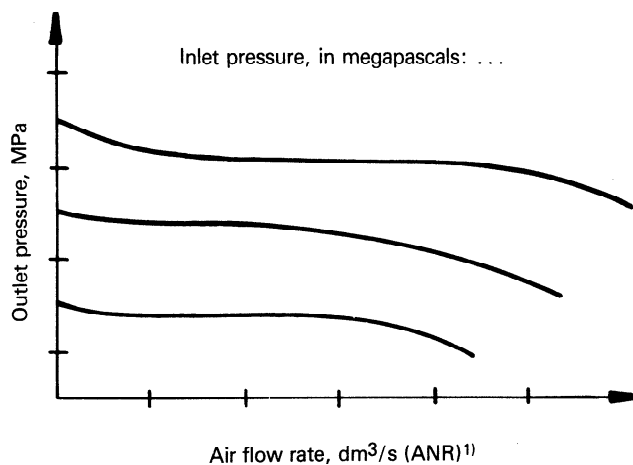

1) See ISO 8778.

**Figure 2 — Air flow rate *versus* outlet pressure**

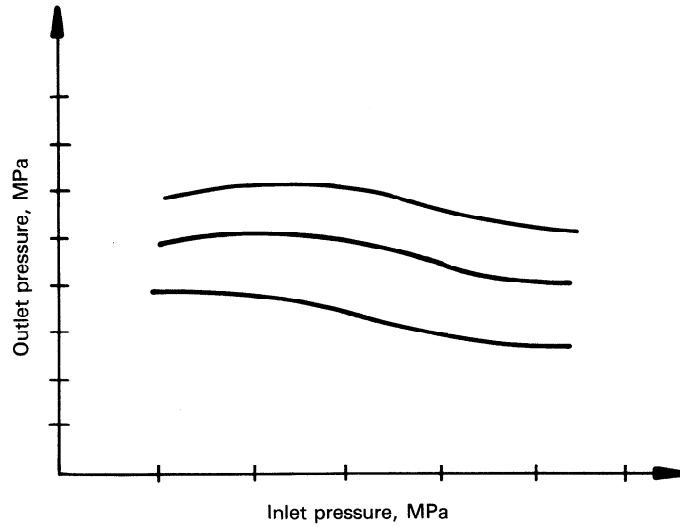

**Figure 3 — Regulation characteristics**  
**iTeh STANDARD PREVIEW**  
**(standards.iteh.ai)**

ISO 6953-1:1990  
<https://standards.iteh.ai/catalog/standards/sist/434dce06-fdaa-44ed-a54e-ddcba0909956/iso-6953-1-1990>

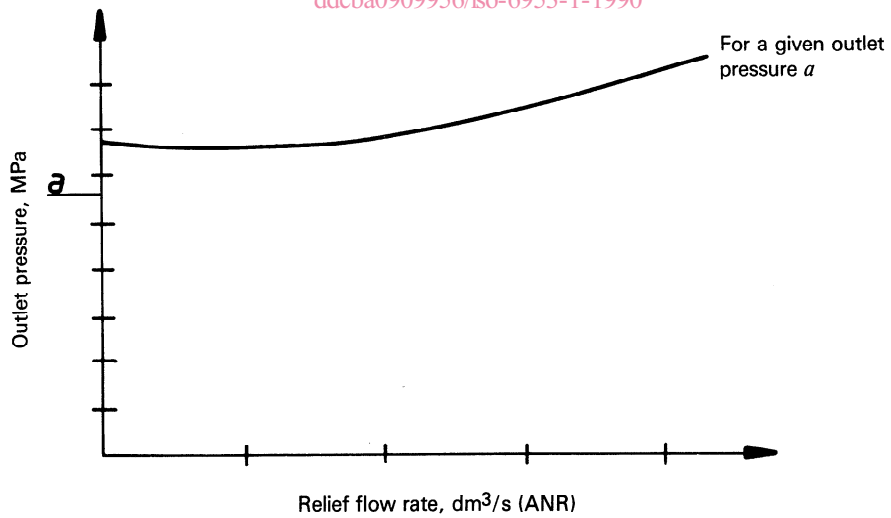

**Figure 4 — Relief flow characteristics**



## 5 Operation and maintenance

All information required for operation and maintenance, including in particular the installation and adjustment requirements and, according to the type of device (with or without relief device), the safety instructions for use with gases other than air shall be provided.

## 6 Marking

**6.1** The air line pressure regulators shall be marked with the following information :

- a) when space permits, the supplier's name and regulator identification data;
- b) maximum inlet pressure;
- c) maximum outlet or secondary pressure;
- d) indication of whether the regulator is relieving or non-relieving;
- e) range of operating temperature;
- f) direction of air flow.

**6.2** Other data may also be marked on air line pressure regulators, for example date code:

## 7 Test methods

See 4.1.5, 4.2.2, 4.2.3 and 4.2.4 for definitions of the test requirements of air line pressure regulators.

NOTE — The values of these characteristics should be obtained according to ISO 6953-2, the test standard for air line pressure regulators.

**8 Identification statement** (reference to this part of ISO 6953)

Use the following statement in test reports, catalogues and sales literature when electing to comply with this part of ISO 6953 :

"Characteristics and requirements for air line pressure regulators are in accordance with ISO 6953-1, *Pneumatic fluid power — Air line pressure regulators — Part 1: Main characteristics to be included in commercial literature and specific requirements.*"

**ITeh STANDARD PREVIEW**  
(standards.iteh.ai)

ISO 6953-1:1990

<https://standards.iteh.ai/catalog/standards/sist/434dce06-fdaa-44ed-a54e-ddcba0909956/iso-6953-1-1990>