



Designation: D 6330 – 98

Standard Practice for Determination of Volatile Organic Compounds (Excluding Formaldehyde) Emissions from Wood-Based Panels Using Small Environmental Chambers Under Defined Test Conditions¹

This standard is issued under the fixed designation D 6330; the number immediately following the designation indicates the year of original adoption or, in the case of revision, the year of last revision. A number in parentheses indicates the year of last reapproval. A superscript epsilon (ε) indicates an editorial change since the last revision or reapproval.

1. Scope

1.1 The practice measures the volatile organic compounds (VOC), excluding formaldehyde, emitted from manufactured wood-based panels. A pre-screening analysis is used to identify the VOCs emitted from the panel. Emission factors (that is, emission rates per unit surface area) for the VOCs of interest are then determined by measuring the concentrations in a small environmental test chamber containing a specimen. The test chamber is ventilated at a constant air change rate under the standard environmental conditions. For formaldehyde determination, see Test Method D 6007.

1.2 This practice describes a test method that is specific to the measurement of VOC emissions from newly manufactured individual wood-based panels, such as particleboard, plywood, and oriented strand board (OSB), for the purpose of comparing the emission characteristics of different products under the standard test condition. For general guidance on conducting small environmental chamber tests, see Guide D 5116.

1.3 VOC concentrations in the environmental test chamber are determined by adsorption on an appropriate single adsorbent tube or multi-adsorbent tube, followed by thermal desorption and combined gas chromatograph/mass spectrometry (GC/MS) or gas chromatograph/flame ionization detection (GC/FID). The air sampling procedure and the analytical method recommended in this practice are generally valid for the identification and quantification of VOCs with saturation vapor pressure between 500 and 0.01 kPa at 25 °C, depending on the selection of adsorbent(s).

NOTE 1—VOCs being captured by an adsorbent tube depend on the adsorbent(s) and sampling procedure selected (see Practice D 6196). The user should have a thorough understanding of the limitations of each adsorbent used.

1.4 The emission factors determined using the above procedure describe the emission characteristics of the specimen under the standard test condition. These data can be used

directly to compare the emission characteristics of different products and to estimate the emission rates up to one month after the production. They shall not be used to predict the emission rates over longer periods of time (that is, more than one month) or under different environmental conditions.

1.5 Emission data from chamber tests can be used for predicting the impact of wood-based panels on the VOC concentrations in buildings by using an appropriate indoor air quality model, which is beyond the scope of this practice.

1.6 The values stated in SI units shall be regarded as the standard (see Practice E 380).

1.7 *This practice does not purport to address all of the safety concerns, if any, associated with its use. It is the responsibility of the user of the standard to consult and establish appropriate safety and health practices and determine the applicability of regulatory limitations prior to use.* For specified hazard statements see Section 6.

2. Referenced Documents

2.1 ASTM Standards:

- D 1356 Terminology Relating to Sampling and Analysis of Atmospheres²
- D 1914 Practice for Conversion Units and Factors Relating to Sampling and Analysis of Atmospheres²
- D 5116 Guide for Small-Scale Environmental Chamber Determinations of Organic Emissions from Indoor Materials/Products²
- D 6007 Test Method for Determining Formaldehyde Concentration in Air from Wood Products Using a Small Scale Chamber³
- D 6196 Practice for Selection of Sorbents and Pumped Sampling/Thermal Desorption Analysis Procedures for Volatile Organic Compounds in Air²
- E 355 Practice for Gas Chromatography Terms and Relationships⁴
- E 380 Practice for Use of the International System of Units

¹ This practice is under the jurisdiction of ASTM Committee D-22 on Sampling and Analysis of Atmospheres and is the direct responsibility of Subcommittee D22.05 on Indoor Air.

Current edition approved Oct. 10, 1998. Published January 1999.

² *Annual Book of ASTM Standards*, Vol 11.03.

³ *Annual Book of ASTM Standards*, Vol 04.10.

⁴ *Annual Book of ASTM Standards*, Vol 14.02.

(SI) (the Modernized Metric System)⁴
 E 741 Test Method for Determining Air Change in a Single Zone by Means of a Tracer Gas Dilution⁵

2.2 Other Standard:

EPA TO-17 Determination of Volatile Organic Compounds in Ambient Air Using Active Sampling Onto Sorbent Tubes, Compendium of Methods for the Determination of Toxic Organic Compounds in Ambient Air

3. Terminology

3.1 *Definitions*—For definitions and terms that are commonly used, refer to Terminology D 1356 and Practice E 355. For definitions and terms related to test methods using small-scale environmental chamber, refer to Guide D 5116. For an explanation of units, symbols, and conversion factors, refer to Practice D 1914.

3.2 Definitions of Terms Specific to This Standard:

3.2.1 *environmental enclosure*—a container or space in which the environmental test chamber(s) is placed. The enclosure has controlled temperature and relative humidity.

3.2.2 *loading ratio* (m^2/m^3)—the total exposed surface area of each test specimen divided by the net air volume of the environmental test chamber.

3.2.3 *nominal time constant* (t_n)—the time required to obtain one air change in the environmental test chamber, which is equal to the inverse of the air change rate.

3.2.4 *pre-screening analysis*—a procedure for identifying the VOCs emitted from a test specimen. The results are used to determine the appropriate GC/MS or GC/FID analytical method for subsequent dynamic chamber tests.

3.2.5 *standard environmental test chamber condition*—a test condition of temperature at $23 \pm 0.5^\circ\text{C}$, relative humidity (RH) at $50 \pm 5\%$, air change rate per hour in the chamber at 1 ± 0.03 ACH, and chamber loading ratio at $0.40 \pm 0.01 m^2/m^3$.

3.2.5.1 *Discussion*—The VOC emission rates for wood-based panel products are generally controlled by VOC diffusions within the material. The airflow condition (air velocity and turbulence) over the test specimen has minimal effect on the emission rates; therefore, it is not specified in the standard test condition.

3.2.6 *tracer gas*—a gaseous compound that is neither emitted by the wood-based panel nor present in the supply air to the chamber. It can be used to determine the mixing characteristics of the environmental test chamber, and it provides a cross-check of the air change rate measurements.

3.2.7 *TVOC*—total concentration of all the individual volatile organic compounds (VOC) captured from air by a given sorbent, or a given combination of several sorbents, thermally desorbed into and eluted from a given gas chromatographic system and measured by a given detector. For VOC definition, see Terminology D 1356.

3.2.7.1 *Discussion*—The measured value of TVOC will depend on the collection and desorption efficiency of the sorbent trap, the efficiency of transfer to the GC column, the type and size of the GC column, the GC temperature program

and other chromatographic parameters, and the type of GC detector. One way to report TVOC values is recommended in 8.2.7.6.

3.2.8 *wood-based panel test specimen*—a specimen of a panel cut from an original wood-based panel sample, such as particleboard, oriented strand board (OSB), or plywood.

4. Significance and Use

4.1 The effects of VOC sources on the indoor air quality in buildings have not been well established. One basic requirement that has emerged from indoor air quality studies is the need for well-characterized test data on the emission factors of VOCs from building materials. Standard test method and procedure are a requirement for the comparison of emission factor data from different products.

4.2 This practice describes a procedure for using a small environmental test chamber to determine the emission factors of VOCs from wood-based panels over a specified period of time. A pre-screening analysis procedure is also provided to identify the VOCs emitted from the products, to determine the appropriate GC/MS or GC/FID analytical procedure, and to estimate required sampling volume for the subsequent environmental chamber testing.

4.3 Test results obtained using this practice provide a basis for comparing the VOC emission characteristics of different wood-based panel products. The emission data can be used to inform manufacturers of the VOC emissions from their products. The data can also be used to identify building materials with reduced VOC emissions over the time interval of the test.

4.4 While emission factors determined by using this practice can be used to compare different products, the concentrations measured in the chamber shall not be considered as the resultant concentrations in an actual indoor environment.

5. Apparatus

5.1 This practice requires the use of an environmental chamber test system, an air sample collection system, and a chemical analysis system. A general guide for conducting small environmental chamber tests is provided in Guide D 5116. The following paragraphs describe the requirements that are specific to this practice:

5.2 *Environmental Chamber Testing System*—The system shall include an environmental test chamber, an environmental enclosure, equipment for supplying clean and conditioned air to the chamber, and outlet fittings for sampling the air exhausted from the chamber. Fig. 1 illustrates an example of such systems. All materials and components in contact with panel specimen or air stream from the chamber inlet to sample collection point shall be chemically inert and accessible for cleaning. Suitable materials include stainless steel and glass. All gaskets and flexible components shall be made from chemically inert materials.

5.2.1 *Environmental Test Chamber*—The chamber should have a volume of $0.05 m^3$ with the interior dimensions of 0.5 by 0.4 by 0.25-m high. A chamber with a different size and shape may also be used if the same standard environmental test chamber conditions (see 3.2.6) can be maintained. The chamber shall include a supply air system having an inlet port with distributed openings to assist mixing between the supply air

⁵ Annual Book of ASTM Standards, Vol 04.11.

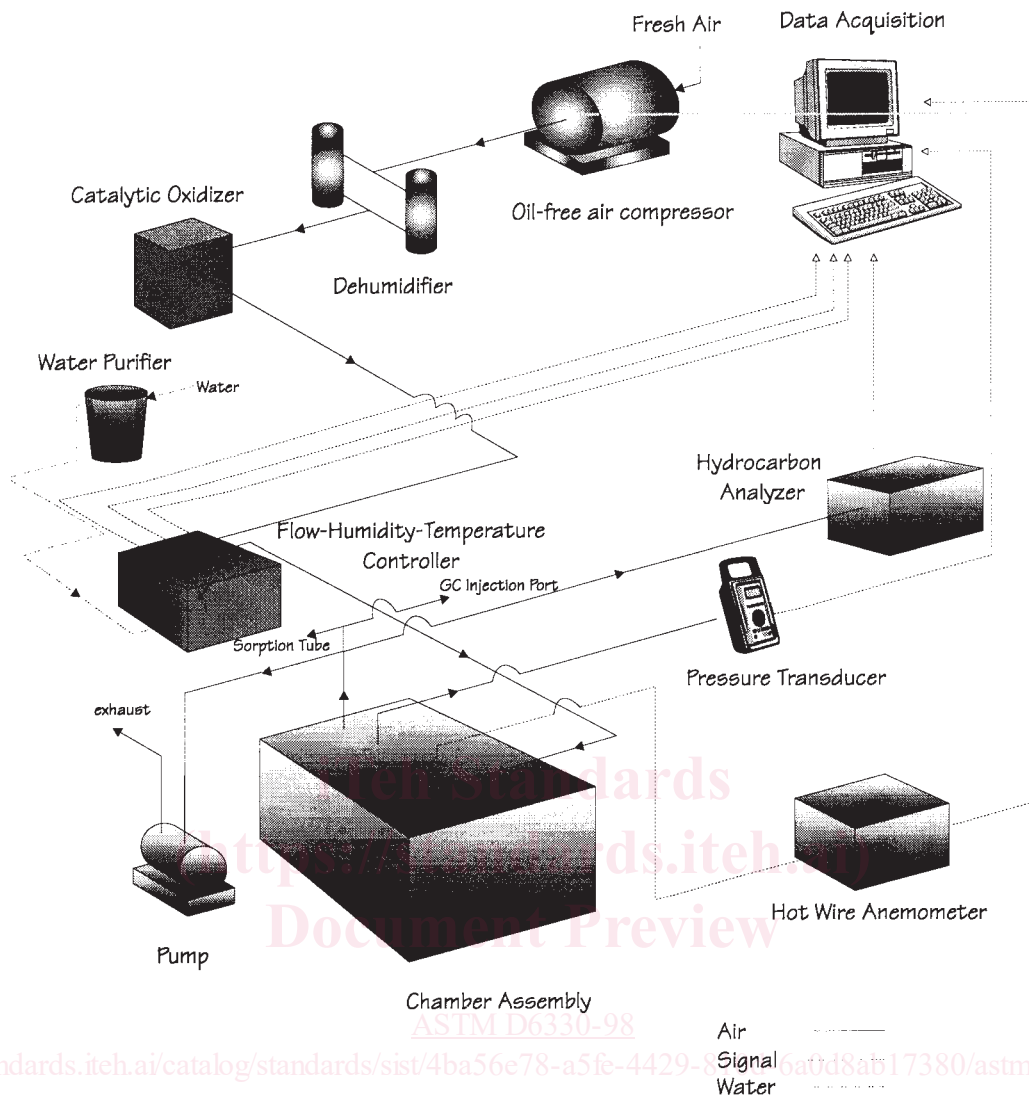

NOTE 1—The chamber assembly should be contained in an environmental enclosure to maintain the required temperature.

FIG. 1 Schematic of an Example Small Chamber Test System

and chamber air and an outlet port with distributed exhaust openings to ensure that concentration measured at the chamber exhaust is the average concentration in the chamber. The chamber criteria are as follows:

5.2.1.1 *Air-Tightness of the Chamber*—The nominal air leakage rate of the chamber shall be less than 1 % of the air change rate used for the emission test at 10 Pa. Air-tightness is measured as follows: (1) seal the outlet of the chamber; (2) supply air to the chamber through the inlet and adjust the airflow rate so that the pressure difference between the inside and outside of the chamber is maintained at 10 ± 1 Pa, which is measured by a pressure transducer with a minimum specified accuracy of ± 1 Pa; and (3) measure the airflow rate. The rate is the nominal leakage rate of the chamber.

5.2.1.2 *Air Mixing in the Chamber*—Adequate air mixing in the chamber shall be achieved to ensure that concentrations measured at the chamber exhaust are representative of those in the chamber. This may be determined by using the following tracer gas decay method: (1) place a small mixing fan (for

example, a personal computer cooling fan) in the chamber; (2) operate the chamber under the standard test condition and turn on the mixing fan; (3) inject a small amount (a pulse) of an inert tracer gas (for example, SF_6) into the chamber directly or by means of the supply air; (4) allow 5 min for the gas to mix with the chamber air; (5) turn off the mixing fan and record the time as $t = 0$; and (6) measure the concentrations of the tracer gas at the exhaust of the chamber at the following time points: $t = 0, 0.25 t_n, 0.5 t_n, 1.0 t_n, 1.5 t_n,$ and $2.0 t_n$, where t_n is the nominal time constant and is equal to 1.0 h for the standard test condition. The measured concentrations are compared to the values given by the following theoretical equation under the perfect mixing condition (in which the concentrations measured at the exhaust are the same as those in the chamber):

$$C_{(t)} = C_0 e^{-Nt} \quad (1)$$

where:

C_0 = initial concentration at $t=0$, $\mu\text{g}/\text{m}^3$,

$C_{(t)}$ = concentration at time t , $\mu\text{g}/\text{m}^3$,
 N = air change rate, h^{-1} , and
 t = time from the start of the air purging, h .

The maximum difference between the measured and calculated theoretical values shall be within $\pm 5\%$ of the theoretical value. The above mixing test shall be conducted with a simulated test specimen placed in the chamber.

NOTE 2—The above test method is a simplified version of the decay method described in Guide D 5116. Alternatively, the method of determining adequate air mixing described in Guide D 5116 may also be used to check the mixing condition in the chamber.

5.2.1.3 *Sample Specimen Holder*—A sample specimen holder shall be used to hold the test specimen so that only the test surface of the specimen is exposed to the chamber air. The

holder shall be designed to minimize the emissions from edges and non-testing surface of the specimen. A design example is shown in Fig. 2.

5.2.1.4 *Sink Effect*—The chamber and specimen holder shall have minimum sink effect. The recovery factor determined by the following procedure shall be higher than 95% for decane: (1) seal the supply inlet and exhaust of the chamber; (2) inject $5\ \mu\text{g}$ of vaporized decane into the chamber; (3) take an air sample from the chamber exhaust at 5 min after the injection, and record this concentration as the initial concentration C_0 and the time as $t = 0$; (4) at $t = 0$, begin purging the air through the chamber at $t = 0$ under standard test conditions; (5) take air samples from the chamber exhaust at the following times after the start of purging: $t_1 = 0.25\ t_n$, $t_2 = 0.5\ t_n$, $t_3 = 1.0\ t_n$, $t_4 = 1.5$

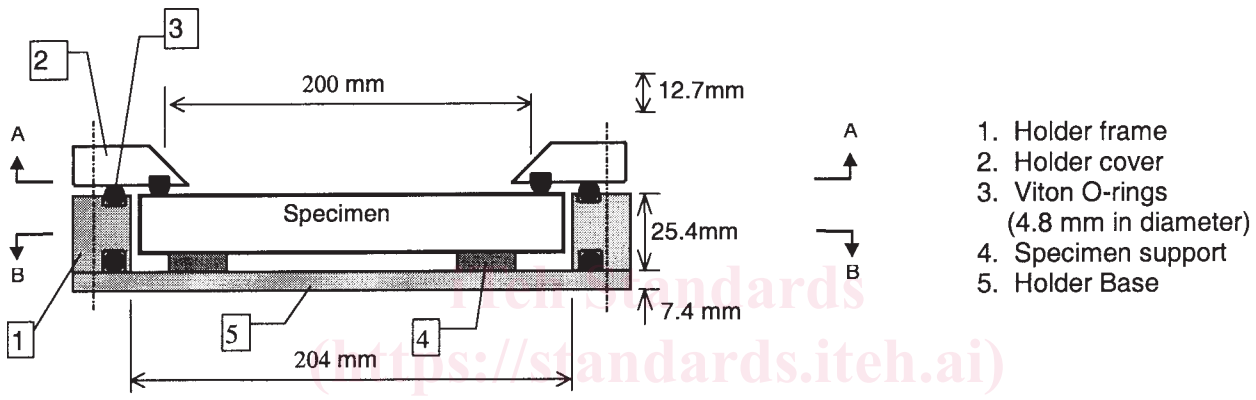

Document Preview

ASTM D6330-98

<https://standards.iteh.ai/catalog/standards/sist/4ba56e78-a5fe-4429-810d-6a0d8ab17380/astm-d6330-98>

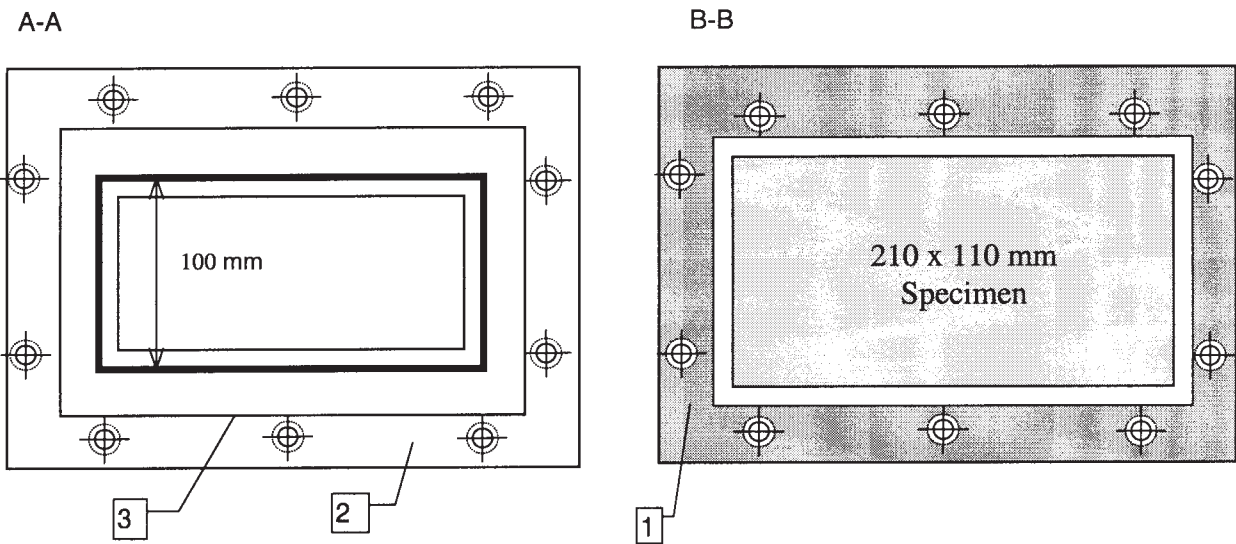

NOTE 1—All materials for the sample holder should be made of electropolished stainless steel.

FIG. 2 Schematic of an Example Sample Holder

t_n , $t5 = 2.0 t_n$, $t6 = 3.0 t_n$, $t7 = 4.5 t_n$, $t8 = 6 t_n$, $t9 = 8 t_n$, and $t10 = 10 t_n$, where t_n is the nominal time constant and is equal to 1.0 h for the standard test condition; and (6) calculate the recovery factor (RF) as follows:

$$RF = \frac{N}{2C_0} \sum_{i=0}^{n-1} [C(t_i) + C(t_{i+1})](t_{i+1} - t_i) 100 \% \quad (2)$$

where:

- RF = recovery factor, %,
- N = air change rate, h^{-1} ,
- C_0 = initial concentration at $t=0$, $\mu\text{g}/\text{m}^3$,
- $C(t_i)$ = concentration at time t_i , $\mu\text{g}/\text{m}^3$ ($i=0, 1, 2, \dots, 10$), and
- t_i = time from the start of the air purging, h.

The above sink effect test should be conducted after the mixing condition in the chamber has been verified (see 5.2.1.2).

NOTE 3—The concentration decay is usually close to the first-order exponential decay curve (that is, $C(t)/C_0 = e^{-Nt}$). The above sampling time intervals are chosen such that the amount of concentration decrease during each sampling interval will be similar.

5.2.1.5 The environmental test chamber shall be contained in an environmental enclosure (see 5.2.2).

5.2.1.6 The background concentration of the environmental test chamber is measured at the chamber exhaust. The background concentration shall meet the following criteria: (1) $20 \mu\text{g}/\text{m}^3$ or $1/6$ of the lowest concentration to be measured, whichever is lower, for TVOC, and (2) $1 \mu\text{g}/\text{m}^3$ or $1/6$ of the lowest concentrations to be measured, whichever is lower, for individual VOCs.

NOTE 4—Conventionally, the minimum quantifiable concentration is determined by:

$$C_{min} = c + 10 s \quad (3)$$

where:

- C_{min} is the minimum quantifiable concentration,
- c is the mean background concentration, and
- s is the standard deviation of the background concentration during the test period.

For simplicity, it may be assumed that $s = 0.5 c$. As a result, $C_{min} = 6 c$.

NOTE 5—The $20 \mu\text{g}/\text{m}^3$ limit set for TVOC in chamber air is the minimum level of cleanliness that a test chamber system shall have.

5.2.2 *Environmental Enclosure*—The enclosure is the surrounding environment of the test chamber that can maintain the temperature at $23.0 \pm 0.5^\circ\text{C}$ and relative humidity at $50 \pm 5\%$ RH during the period of loading the test specimen, and maintain the temperature at $23.0 \pm 0.5^\circ\text{C}$ during the entire testing period. Once the chamber door is closed, the relative humidity in the chamber is maintained by the air supply to the chamber. A temperature ($23.0 \pm 0.5^\circ\text{C}$) and humidity ($50 \pm 5\%$ RH) controlled room is found to be adequate for this purpose. Otherwise, a stand-alone structure has to be built as the environmental enclosure.

5.2.3 *Clean Air Supply System*—The system shall be capable of supplying a controlled flow of clean air into the test chamber. Concentrations measured at the chamber inlet shall meet the following criteria at an airflow rate ≥ 1.0 chamber volume per hour:

- TVOC (as defined in 5.4.5.4) concentration $\leq 10 \mu\text{g}/\text{m}^3$,
- concentration of any individual VOC $\leq 0.5 \mu\text{g}/\text{m}^3$,

particulate concentration ≤ 100 particles/ m^3 of $0.5\text{-}\mu\text{m}$ diameter or larger, and

ozone concentration $\leq 3 \mu\text{g}/\text{m}^3$.

A typical clean air supply system should include the following components (see Fig. 1):

5.2.3.1 An air pump(s) or an oil-free compressor capable of supplying air at a rate of 1.0 chamber volume per hour. A particulate filter shall be installed on the air intake.

5.2.3.2 A dehumidifier (for example, a desiccant drier) capable of keeping the relative humidity below 45 % RH.

5.2.3.3 A catalytic oxidizer or equivalent air purifier (for example, activated carbon filter) capable of removing organic compounds so that the concentrations of TVOC and any individual VOCs are below $10 \mu\text{g}/\text{m}^3$ and $0.5 \mu\text{g}/\text{m}^3$, respectively.

5.2.3.4 An air conditioning device and an airflow controller capable of controlling the airflow rate, temperature, and relative humidity of the supply air at 1.0 ± 0.03 ACH, $23.0 \pm 0.5^\circ\text{C}$ and $50 \pm 5\%$ RH, respectively. Deionized water (or equivalent) shall be used in the humidification.

5.2.3.5 An exhaust air pump and an airflow controller for controlling the pressure in the chamber. The airflow controller shall be adjusted so that the air pressure in the chamber will be positive relative to air pressure outside the chamber despite the fluctuations in the ambient air pressure. A typical pressure to be maintained in the chamber is 10 ± 5 Pa relative to the ambient pressure outside of the chamber.

5.2.3.6 Sensors and a recording system for monitoring airflow rate, temperature, relative humidity, and pressure inside the environmental test chamber.

5.3 *Air Sampling System*—The system shall include an adsorbent tube, a mechanical pump, and an airflow controller, which can measure and control the airflow rate through the sampling system to within $\pm 5\%$ of a specified value. All system components between the chamber and the adsorbent tube shall be constructed of chemically inert materials.

5.3.1 The adsorbent tube should be connected as close to the chamber exhaust as possible by using a short (<0.15 m from the environmental enclosure) stainless steel or PTFE tube/connector. The pump shall be operated in vacuum mode downstream of the adsorbent tube to avoid contamination of air samples by the pump.

5.3.2 For effective collections of VOCs in the exhaust air of the test chamber, an appropriate single or multi-layered adsorbent tube should be used depending on the VOCs to be measured.

5.3.3 Sampling of the exhaust air shall not affect the control of airflow rate to the test chamber. The airflow controller for the exhaust air pump shall be adjusted before air sampling so that the air pressure in the chamber will remain positive during the sample collection period. A sampling flow rate of less than one third of the total supply airflow rate to the test chamber is recommended to avoid excessive depressurization in the chamber during the sampling period. The manufacturer's recommendations for proper use of adsorbent tubes shall be followed for selecting the sampling airflow rate and for the sampling period to avoid breakthrough of VOCs. Air sample volumes (that is, sampling flow rate times the sampling period) should

be determined by (1) the safe sampling volume (SSV, see Practice D 6196) of the least retained VOC, (2) concentrations to be measured, (3) and detection limits of the analytical method. Proper air sample volumes may be determined by use of data from the pre-screening analysis (see 8.1).

5.4 Chemical Analysis System—The chemical analysis system shall include a thermal desorption unit connected to a GC/MS system or a GC/FID system. EPA TO-17 may be consulted for general procedures of determining VOCs in air sample. The chemical analysis system that is specific to this practice is as follows:

5.4.1 A single or multi-tube thermal desorption (TD) unit shall have desorption efficiency of greater than 90 % for VOCs of interest in general, and 100 ± 5 % for toluene, decane, and dodecane at 50 ng per compound per tube. Desorption efficiency should be determined by comparing results from thermal desorption with direct GC injection.

5.4.2 GC/MS system can be used for both identification of VOCs in the pre-screening analysis and quantification of the VOCs in emissions from the environmental chamber tests.

5.4.2.1 For identification of VOCs, the GC/MS is operated in the scan mode and shall be capable of scanning the mass range from 15 to 350 amu (atomic mass unit). The measured mass spectrum shall be compared to those in a standard mass spectrum library to identify the individual VOCs detected. Selected VOCs of interest shall be confirmed by spiking with the corresponding standards (see 8.1).

5.4.2.2 For quantification of individual VOCs of interest, the GC/MS system shall be operated in the scan mode or in the selected ion monitoring (SIM) modes. If SIM mode is selected, at least three ions shall be monitored for each VOC of interest. Other conditions used in 5.4.2.1 shall be maintained.

5.4.3 GC/FID system can be used for quantification of VOCs of interest as an alternative to GC/MS. The identification of the VOCs of interest in a GC/FID chromatogram shall be confirmed by GC/MS analysis and by spiking with the corresponding standards (see 8.1).

5.4.4 Optimal operating conditions (GC column and temperature program) shall be determined for GC/MS and GC/FID system based on data from the pre-screening analysis (see 8.1).

5.4.5 Chemical and analytical system shall be properly calibrated for quantitative analysis. Initial calibration of GC/MS or GC/FID system shall be completed before testing each type of product material. Initial calibration shall be conducted by analyzing standards of selected VOCs (or toluene for TVOC, see 5.4.5.4) at different concentrations. At least five different concentrations covering anticipated VOC concentration range in the test are needed for such calibration. The user of this practice shall demonstrate that the analytical system has a linear response over the anticipated VOC concentration range.

5.4.5.1 If GC/FID system is used for the quantification, single point calibration checking shall be conducted on each day the system is used. If the result of such single point checking deviates less than ± 10 % from the initial calibration line, the initial calibration line shall be used to calculate the

mass concentrations. Otherwise, the problem shall be identified and the system fully re-calibrated as in the initial calibration (see 5.4.5).

5.4.5.2 If GC/MS system is used for the quantification, daily calibration shall be conducted at two concentration levels (that is, a two-point calibration) as a minimum. The low point should be where the linearity of the calibration curve starts or ten times the method detection limit, whichever is higher. The high point should be where the linearity of the calibration curve ends or the anticipated highest concentration in the samples, whichever is lower. Results of this daily calibration shall be used to calculate the concentrations if they deviate less than 10 % from the previous day and less than 25 % from the initial calibration. Otherwise, the problem shall be identified and the system fully re-calibrated as in the initial calibration (see 5.4.5).

NOTE 6—Different calibration practices are specified for GC/FID (see 5.4.5.1) and GC/MS (see 5.4.5.2) system because a GC/MS system is usually subject to more day to day variations than a GC/FID system.

5.4.5.3 If the testing objective is to measure the emission factors of target individual compound, the TD-GC/MS or TD-GC/FID system shall be calibrated for each individual compound with standards of the same compound.

5.4.5.4 If the testing objective is to measure TVOC concentration, the TD-GC/FID system or TD-GC/MS system shall be calibrated by using toluene as the reference standard. The result shall be reported as the concentration of toluene equivalent TVOC-by-GC/FID or TVOC-by-GC/MS, depending on which system is used. GC/MS system in this case shall be operated in full scan mode (15 to 350 amu) and peak areas of the total ion currency shall be used.

5.4.5.5 If the testing objective is to measure both the concentrations of TVOC and individual target compounds, the TD-GC/FID system or TD-GC/MS system shall be calibrated for both toluene and individual target compounds.

5.5 The method detection limit of the system shall be less than one third of the lowest concentration to be measured.

6. Hazards

6.1 The transportation, handling, cutting, testing and clean-up of wood-based panel materials involve a number of chemical and physical hazards.

6.2 Proper workplace health and safety procedures and good laboratory practice shall be developed and implemented.

6.3 Chemicals—Appropriate procedures shall be developed and implemented for using and disposing of chemicals for cleaning and calibration.

7. Material Sampling, Storage, Preparation of a Test Specimen, and Its Placement in the Environmental Test Chamber

7.1 Material Collection, Packaging, and Transportation:

7.1.1 Sample materials shall be handled in an unbiased manner. They should be collected at the point of manufacturer by a qualified person and delivered directly to the testing laboratory using the following procedure:

7.1.1.1 Select one panel from the center of a freshly (within a week) manufactured stack.