

INTERNATIONAL STANDARD

**ISO
6981**

Second edition
1992-03-15

Hydraulic fluid power — Cylinders — Rod end plain eyes — Mounting dimensions

iTeh STANDARD PREVIEW
*Transmissions hydrauliques — Vérins — Tenons simples d'extrémité de
tige de piston — Dimensions d'interchangeabilité*
(standards.iteh.ai)

ISO 6981:1992

<https://standards.iteh.ai/catalog/standards/sist/b4f64b10-66fb-4462-8269-67860d31b5f4/iso-6981-1992>



Reference number
ISO 6981:1992(E)

Foreword

ISO (the International Organization for Standardization) is a worldwide federation of national standards bodies (ISO member bodies). The work of preparing International Standards is normally carried out through ISO technical committees. Each member body interested in a subject for which a technical committee has been established has the right to be represented on that committee. International organizations, governmental and non-governmental, in liaison with ISO, also take part in the work. ISO collaborates closely with the International Electrotechnical Commission (IEC) on all matters of electrotechnical standardization.

Draft International Standards adopted by the technical committees are circulated to the member bodies for voting. Publication as an International Standard requires approval by at least 75 % of the member bodies casting a vote.

International Standard ISO 6981 was prepared by Technical Committee ISO/TC 131, *Fluid power systems*, Sub-Committee SC 3, *Cylinders*.

This second edition cancels and replaces the first edition (ISO 6981:1982), figure 1 and table 1 of which have been technically revised.

Annex A of this International Standard is for information only.

© ISO 1992

All rights reserved. No part of this publication may be reproduced or utilized in any form or by any means, electronic or mechanical, including photocopying and microfilm, without permission in writing from the publisher.

International Organization for Standardization
Case Postale 56 • CH-1211 Genève 20 • Switzerland

Printed in Switzerland

Introduction

In hydraulic fluid power systems, power is transmitted and controlled through a fluid (liquid or gas) under pressure within an enclosed circuit.

One component of such systems is the fluid power cylinder. This is a device which converts power into linear mechanical force and motion. It consists of a movable element, i.e. a piston and piston rod, operating within a cylindrical bore.

iTeh STANDARD PREVIEW (standards.iteh.ai)

[ISO 6981:1992](#)

<https://standards.iteh.ai/catalog/standards/sist/b4f64b10-66fb-4462-8269-67860d31b5f4/iso-6981-1992>

iTeh STANDARD PREVIEW
(standards.iteh.ai)

This page intentionally left blank
ISO 6981:1992

<https://standards.iteh.ai/catalog/standards/sist/b4f64b10-66fb-4462-8269-67860d31b5f4/iso-6981-1992>

Hydraulic fluid power — Cylinders — Rod end plain eyes — Mounting dimensions

1 Scope

This International Standard specifies the mounting dimensions required for interchangeability of rod end plain eyes of hydraulic cylinders. The rod end plain eyes have been designed specifically for use with cylinders manufactured in accordance with ISO 6020-1 and ISO 6022, but this does not limit their application.

The plain bearing end eyes are used on piston rods of hydraulic cylinders for mechanically transmitting the cylinder force. The design of these eyes is based on the maximum forces resulting from the specified internal diameters of the cylinders and pressures according to ISO 3320 and ISO 3322.

2 Normative references

The following standards contain provisions which, through reference in this text, constitute provisions of this International Standard. At the time of publication, the editions indicated were valid. All standards are subject to revision, and parties to agreements based on this International Standard are encouraged to investigate the possibility of applying the most recent editions of the standards indicated below. Members of IEC and ISO maintain registers of currently valid International Standards.

ISO 286-2:1988, *ISO system of limits and fits — Part 2: Tables of standard tolerance grades and limit deviations for holes and shafts.*

ISO 3320:1987, *Fluid power systems and components — Cylinder bores and piston rod diameters — Metric series.*

ISO 3322:1985, *Fluid power systems and components — Cylinders — Nominal pressures.*

ISO 5598:1985, *Fluid power systems and components — Vocabulary.*

ISO 6020-1:1981, *Hydraulic fluid power — Single rod cylinders — Mounting dimensions — 160 bar (16 000 kPa) series — Part 1: Medium series.*

ISO 6022:1981, *Hydraulic fluid power — Single rod cylinders — Mounting dimensions — 250 bar (25 000 kPa) series.*

3 Definitions

For the purposes of this International Standard, the definitions given in ISO 5598 apply.

4 Mounting dimensions

See figure 1 and table 1.

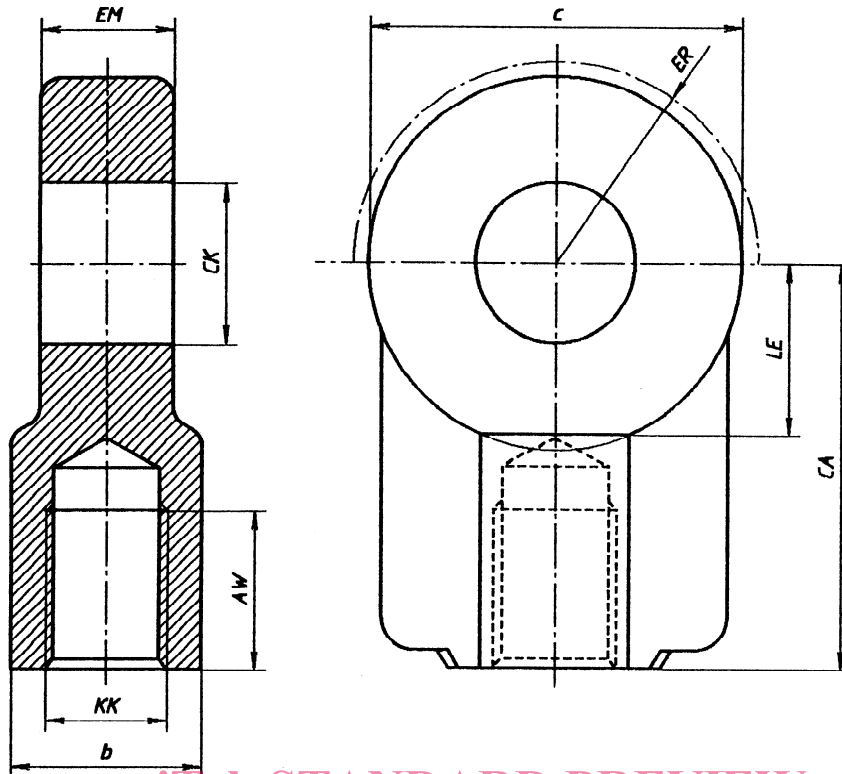

STANDARD PREVIEW
(standards.iteh.ai)

NOTE — A suitable locking device shall be used.

Figure 1 — Rod end plain eyes

ISO 6981:1992

<https://standards.iteh.ai/catalog/standards/sist/b4f64b10-66fb-4462-8269-67860d31b5f4/iso-6981-1992>

Table 1 — Dimensions of rod end plain eyes

Dimensions in millimetres

Type	Nominal force N	CK H9 ¹⁾	EM h12 ¹⁾	KK	AW min.	CA	LE	c max.	ER	b
10	5 000	10	10	M10 × 1,25	14	37	14	32	16	15
12	8 000	12	12	M12 × 1,25	17	38	14	32	16	16
16	12 500	16	16	M14 × 1,5	19	44	18	40	20	21
20	20 000	20	20	M16 × 1,5	23	52	22	50	25	25
25	32 000	25	25	M20 × 1,5	29	65	27	62	32	30
32	50 000	32	32	M27 × 2	37	80	32	76	40	38
40	80 000	40	40	M33 × 2	46	97	41	97	50	47
50	125 000	50	50	M42 × 2	57	120	50	118	63	58
63	200 000	63	63	M48 × 2	64	140	62	142	71	70
80	320 000	80	80	M64 × 3	86	180	78	180	90	90
100	500 000	100	100	M80 × 3	96	210	98	224	112	110
125	800 000	125	125	M100 × 3	113	260	120	290	160	135
160	1 250 000	160	160	M125 × 4	126	310	150	346	200	165
200	2 000 000	200	200	M160 × 4	161	390	195	460	250	215
250	3 200 000	250	250	M200 × 4	205	530	265	640	320	300
320	5 000 000	320	320	M250 × 6	260	640	325	750	375	360

1) See ISO 286-2.

5 General requirements

5.1 Material

5.1.1 Rod end plain eyes shall be made of material having a minimum yield point $R_{p0,2}$ of 250 N/mm² and an elongation at rupture, A min., of at least 12 %.

5.2 Load capacity

All cross-sections shall be selected so that, under the maximum tensile load produced by the cylinder, the yield strength of the material used for the rod end is at least 2,5 times the maximum tensile load.

6 Mounting instructions

6.1 Shaft

A tolerance of f8 is recommended for plain bearing shafts (see ISO 286-2).

6.2 Fitting

The rod end plain eye shall be screwed firmly against the piston rod shoulder before locking.

7 Example of ordering designation

A rod end plain eye with a bore $CK = 25$ mm shall be designated as:

Rod end ISO 6981 - 25

8 Identification statement (Reference to this International Standard)

Use the following statement in test reports, catalogues and sales literature when electing to comply with this International Standard:

“Cylinder rod end spherical eye mounting dimensions selected in accordance with ISO 6981:1992, *Hydraulic fluid power — Cylinders — Rod end plain eyes — Mounting dimensions.*”

iTeh STANDARD PREVIEW
(standards.iteh.ai)

ISO 6981:1992

<https://standards.iteh.ai/catalog/standards/sist/b4f64b10-66fb-4462-8269-67860d31b5f4/iso-6981-1992>

Annex A
(informative)

Bibliography

- [1] ISO 6099:1985, *Fluid power systems and components — Cylinders — Identification code for mounting dimensions and mounting types.*

iTeh STANDARD PREVIEW
(standards.iteh.ai)

ISO 6981:1992

<https://standards.iteh.ai/catalog/standards/sist/b4fb4b10-66fb-4462-8269-67860d31b5f4/iso-6981-1992>

iTeh STANDARD PREVIEW
(standards.iteh.ai)

This page intentionally left blank

ISO 6981:1992

<https://standards.iteh.ai/catalog/standards/sist/b4f64b10-66fb-4462-8269-67860d31b5f4/iso-6981-1992>