



SLOVENSKI STANDARD
SIST ISO 7040:1996

01-april-1996

üYglfcVY'nUý]lbY'a UñW'g'd`Ugh] b]a `j`cý_ca `!`H[d`%!`HfXbcghb]`fUnfYX]) ž, `]b`%\$

Prevailing torque type hexagon nuts (with non-metallic insert), style 1 -- Property classes 5, 8 and 10

Écrous hexagonaux à freinage interne, à couple préalable (avec anneau non métallique), style 1 -- Classes de qualité 5, 8 et 10

Ta slovenski standard je istoveten z: **ISO 7040:1983**

SIST ISO 7040:1996
<https://standards.iteh.ai/catalog/standards/sist/d2865fcc-ac06-48d5-b66d-0eb39b30164b/sist-iso-7040-1996>

ICS:

21.060.20 Matice Nuts

SIST ISO 7040:1996 en

iTeh STANDARD PREVIEW
(standards.iteh.ai)

SIST ISO 7040:1996

<https://standards.iteh.ai/catalog/standards/sist/d2863fec-ac06-48d5-b66d-0eb39b30164b/sist-iso-7040-1996>

International Standard 7040

INTERNATIONAL ORGANIZATION FOR STANDARDIZATION • МЕЖДУНАРОДНАЯ ОРГАНИЗАЦИЯ ПО СТАНДАРТИЗАЦИИ • ORGANISATION INTERNATIONALE DE NORMALISATION

Prevailing torque type hexagon nuts (with non-metallic insert), style 1 — Property classes 5, 8 and 10

Écrous hexagonaux à freinage interne, à couple préalable (avec anneau non métallique), style 1 — Classes de qualité 5, 8 et 10

First edition — 1983-09-15

iTeh STANDARD PREVIEW
(standards.iteh.ai)

[SIST ISO 7040:1996](https://standards.iteh.ai/catalog/standards/sist/d2863fec-ac06-48d5-b66d-0eb39b30164b/sist-iso-7040-1996)

<https://standards.iteh.ai/catalog/standards/sist/d2863fec-ac06-48d5-b66d-0eb39b30164b/sist-iso-7040-1996>

UDC 621.882.31

Ref. No. ISO 7040-1983 (E)

Descriptors : fasteners, nuts (fasteners), hexagonal nuts, specifications, dimensions, designation.

Price based on 3 pages

Foreword

ISO (the International Organization for Standardization) is a worldwide federation of national standards bodies (ISO member bodies). The work of developing International Standards is carried out through ISO technical committees. Every member body interested in a subject for which a technical committee has been authorized has the right to be represented on that committee. International organizations, governmental and non-governmental, in liaison with ISO, also take part in the work.

Draft International Standards adopted by the technical committees are circulated to the member bodies for approval before their acceptance as International Standards by the ISO Council.

International Standard ISO 7040 was developed by Technical Committee ISO/TC 2, *Fasteners*, and was circulated to the member bodies in December 1981.

It has been approved by the member bodies of the following countries:

Australia	Hungary	Norway
Belgium	India	Poland
Canada	Ireland	Romania
China	Italy	South Africa, Rep. of
Czechoslovakia	Japan	Spain
Denmark	Korea, Dem. P. Rep. of	Sri Lanka
Egypt, Arab Rep. of	Korea, Rep. of	Sweden
Finland	Mexico	Switzerland
France	Netherlands	
Germany, F.R.	New Zealand	

The member bodies of the following countries expressed disapproval of the document on technical grounds:

United Kingdom
USA
USSR

Prevailing torque type hexagon nuts (with non-metallic insert), style 1 — Property classes 5, 8 and 10

iTeh STANDARD PREVIEW
(standards.iteh.ai)

1 Scope and field of application

This International Standard specifies the characteristics of prevailing torque type hexagon nuts, style 1, with non-metallic annular insert and thread sizes from M 3 to M 36 inclusive, in product grades A ($d < M 16$) and B ($d > M 16$), and property classes 5, 8 and 10.

NOTE — The dimensions of the nuts correspond to those given in ISO 4032 plus prevailing torque feature.

If other specifications are required, it is recommended that they should be selected from existing International Standards, for example ISO 261, ISO 898, ISO 965, ISO 2320, ISO 4759/1.

2 References

ISO 225, *Fasteners — Bolts, screws, studs and nuts — Symbols and designations of dimensions.*

ISO 261, *ISO general purpose metric screw threads — General plan.*

ISO 898, *Mechanical properties of fasteners.*

ISO 965, *ISO general purpose metric screw threads — Tolerances.*

ISO 2320, *Prevailing torque type steel hexagon nuts — Mechanical and performance properties.*

ISO 3269, *Fasteners — Acceptance inspection.*¹⁾

ISO 4032, *Hexagon nuts, style 1 — Product grades A and B.*

ISO 4042, *Threaded components — Electroplated coatings components.*¹⁾

ISO 4759/1, *Tolerances for fasteners — Part 1: Bolts, screws and nuts with thread diameters $> 1,6$ and < 150 mm and product grades A, B and C.*

1) At present at the stage of draft.

3 Dimensions

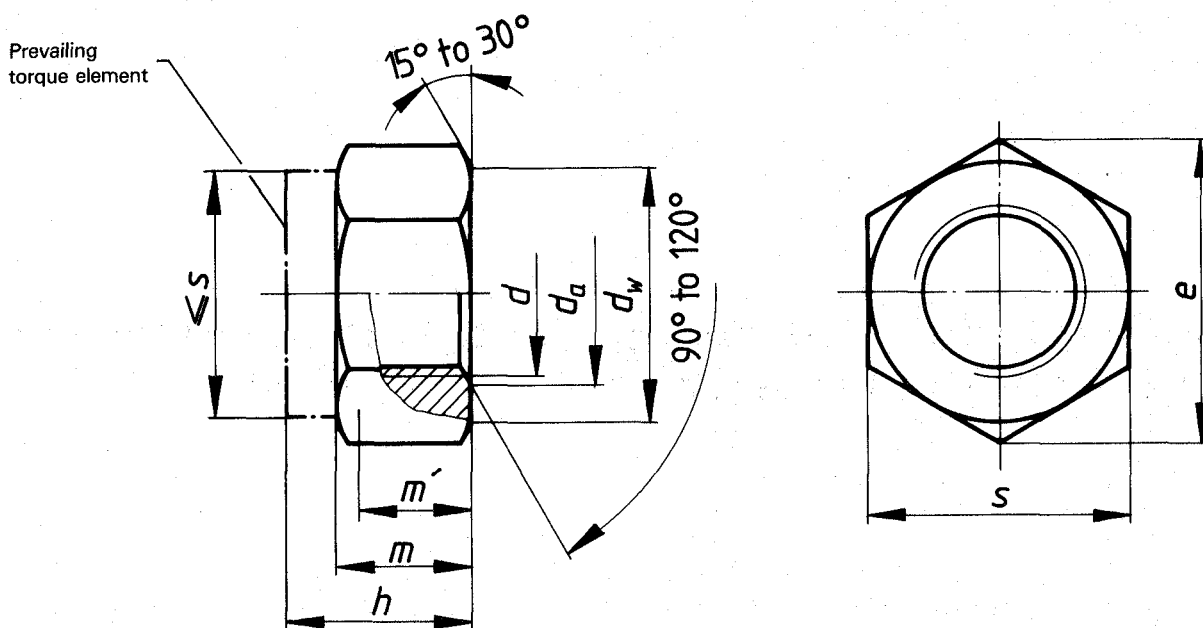

iTeh STANDARD PREVIEW
(standards.iteh.ai)

Dimensions in millimetres

Thread size d	M 3	M 4	M 5	M 6	M 8	M 10	M 12	(M 14) ¹⁾	M 16	M 20	M 24	M 30	M 36
p ²⁾	0,5	0,7	0,8	1	1,25	1,5	1,75	2	2	2,5	3	3,5	4
d_a	min.	3	4	5	6	8	10	12	14	16	20	24	30
	max.	3,45	4,6	5,75	6,75	8,75	10,8	13	15,1	17,3	21,6	25,9	32,4
d_w	min.	4,6	5,9	6,9	8,9	11,6	14,6	16,6	19,6	22,5	27,7	33,2	42,7
	max.	4,6	5,9	6,9	8,9	11,6	14,6	16,6	19,6	22,5	27,7	33,2	42,7
e	min.	6,01	7,66	8,79	11,05	14,38	17,77	20,03	23,35	26,75	32,95	39,55	50,85
	max.	6,01	7,66	8,79	11,05	14,38	17,77	20,03	23,35	26,75	32,95	39,55	50,85
h	min.	4,5	6	6,8	8	9,5	11,9	14,9	17	19,1	22,8	27,1	32,6
	max.	4,5	6	6,8	8	9,5	11,9	14,9	17	19,1	22,8	27,1	32,6
m ³⁾	min.	2,15	2,9	4,4	4,9	6,44	8,04	10,37	12,1	14,1	16,9	20,2	24,3
	max.	2,15	2,9	4,4	4,9	6,44	8,04	10,37	12,1	14,1	16,9	20,2	24,3
m' ⁴⁾	min.	1,65	2,2	2,75	3,3	4,4	5,5	6,6	7,7	8,8	11	13,2	16,5
	max.	1,65	2,2	2,75	3,3	4,4	5,5	6,6	7,7	8,8	11	13,2	16,5
s	min.	5,32	6,78	7,78	9,78	12,73	15,73	17,73	20,67	23,67	29,16	35	45
	max.	5,32	6,78	7,78	9,78	12,73	15,73	17,73	20,67	23,67	29,16	35	45

- 1) The size in brackets should be avoided if possible.
- 2) P = pitch of the thread.
- 3) Also minimum thread height.
- 4) Minimum wrenching height.

4 Specifications and reference International Standards

Nut	Types	NF (normal friction) and LF (low friction)
	International Standard	ISO 2320
Material	Nut body	Steel
	International Standards	ISO 898/2, ISO 2320
	Insert	For example, polyamid
	International Standard	ISO 2320
Thread	Tolerance	6H
	International Standards	ISO 261, ISO 965
Mechanical properties	Property class	5, 8, 10
	International Standards	ISO 898/2, ISO 2320
Torque and other requirements 1)	International Standard	ISO 2320
Tolerances	Product grade	For $d < M16$: A For $d > M16$: B
	International Standard	ISO 4759/1
Finish		As processed Requirements for electroplated coatings are covered in ISO 4042. If different electroplating requirements are desired or if requirements are needed for other finishes, they should be negotiated between customer and supplier.
Acceptability		For acceptance procedure, see ISO 3269.

1) Lubrication is permitted to meet the requirements in ISO 2320.

5 Designation

SIST ISO 7040:1996

Example for the designation of a prevailing torque type hexagon nut, with thread size $d = M12$, property class 8 and normal friction (NF) type:

Prevailing torque type hexagon nut ISO 7040 - M12 - 8 - NF