International Standard



7044

INTERNATIONAL ORGANIZATION FOR STANDARDIZATION • МЕЖДУНАРОДНАЯ ОРГАНИЗАЦИЯ ПО СТАНДАРТИЗАЦИИ • ORGANISATION INTERNATIONALE DE NORMALISATION

Prevailing torque type all-metal hexagon nuts with flange

Écrous hexagonaux à embase cylindro-tronconique, à freinage interne, à couple préalable, tout métal

First edition — 1983-09-01

iTeh STANDARD PREVIEW
(standards.iteh.ai)

[ISO 7044:1983](https://standards.iteh.ai/catalog/standards/sist/ade404c6-fd06-4b87-a4ee-1ccc3a52cc93/iso-7044-1983)

<https://standards.iteh.ai/catalog/standards/sist/ade404c6-fd06-4b87-a4ee-1ccc3a52cc93/iso-7044-1983>

UDC 621.882.31

Ref. No. ISO 7044-1983 (E)

Descriptors : fasteners, nuts (fasteners), hexagonal nuts with flange, hexagonal nuts, specifications, dimensions, designation.

Price based on 4 pages

Foreword

ISO (the International Organization for Standardization) is a worldwide federation of national standards bodies (ISO member bodies). The work of developing International Standards is carried out through ISO technical committees. Every member body interested in a subject for which a technical committee has been authorized has the right to be represented on that committee. International organizations, governmental and non-governmental, in liaison with ISO, also take part in the work.

Draft International Standards adopted by the technical committees are circulated to the member bodies for approval before their acceptance as International Standards by the ISO Council.

International Standard ISO 7044 was developed by Technical Committee ISO/TC 2, *Fasteners*, and was circulated to the member bodies in December 1981.

STANDARD PREVIEW
(standards.iteh.ai)

It has been approved by the member bodies of the following countries:

Australia	Germany, F. R.	New Zealand
Belgium	Hungary	Norway
Brazil	India	Poland
Canada	Ireland	Romania
China	Italy	South Africa, Rep. of
Czechoslovakia	Japan	Spain
Denmark	Korea, Dem. P. Rep. of	Sri Lanka
Egypt, Arab Rep. of	Korea, Rep. of	Sweden
Finland	Mexico	Switzerland
France	Netherlands	USA

The member bodies of the following countries expressed disapproval of the document on technical grounds:

United Kingdom
USSR

Prevailing torque type all-metal hexagon nuts with flange

iTeh STANDARD PREVIEW (standards.iteh.ai)

1 Scope and field of application

This International Standard specifies the characteristics of prevailing torque type all-metal hexagon nuts with flange and thread sizes from M 5 to M 20 inclusive, in product grade A.

NOTE — The dimensions of the nuts correspond to those given in ISO 4161 plus prevailing torque feature.

If other specifications are required, it is recommended that they should be selected from existing International Standards, for example ISO 261, ISO 898, ISO 965, ISO 2320, ISO 4759/1.

2 References

ISO 225, *Fasteners — Bolts, screws, studs and nuts — Symbols and designations of dimensions.*

ISO 261, *ISO general purpose metric screw threads — General plan.*

ISO 898, *Mechanical properties of fasteners.*

ISO 965, *ISO general purpose metric screw threads — Tolerances.*

ISO 2320, *Prevailing torque type steel hexagon nuts — Mechanical and performance properties.*

ISO 3269, *Fasteners — Acceptance inspection.*¹⁾

ISO 4042, *Threaded components — Electroplated coatings components.*¹⁾

ISO 4161, *Hexagon flange nuts — Product grade A.*

ISO 4759/1, *Tolerances for fasteners — Part 1: Bolts, screws and nuts with thread diameters > 1,6 and < 150 mm and product grades A, B and C.*

¹⁾ At present at the stage of draft.

3 Dimensions

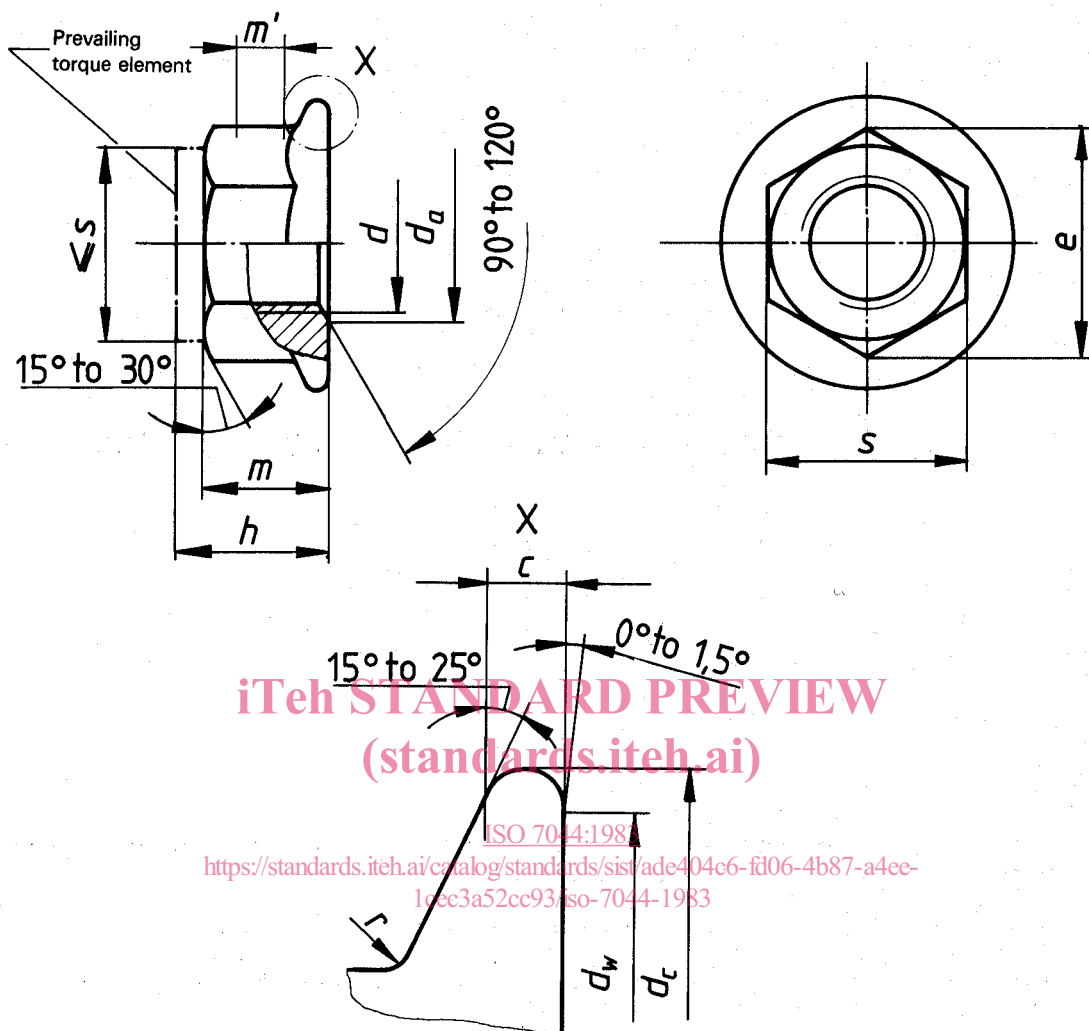

iTeh STANDARD PREVIEW
(standards.iteh.ai)

ISO 7044:1983
<https://standards.iteh.ai/catalog/standards/sist/ade404c6-fd06-4b87-a4cc-10cc3a52cc93/iso-7044-1983>

Dimensions in millimetres

Thread size d		M 5	M 6	M 8	M 10	M 12	(M 14) ¹⁾	M 16	M 20
P ²⁾		0,8	1	1,25	1,5	1,75	2	2	2,5
c	min.	1	1,1	1,2	1,5	1,8	2,1	2,4	3
d_a	min.	5	6	8	10	12	14	16	20
	max.	5,75	6,75	8,75	10,8	13	15,1	17,3	21,6
d_c	max.	11,8	14,2	17,9	21,8	26	29,9	34,5	42,8
d_w	min.	9,8	12,2	15,8	19,6	23,8	27,6	31,9	39,9
e	min.	8,79	11,05	14,38	16,64	20,03	23,36	26,75	32,95
h	max.	6,2	7,3	9,4	11,4	13,8	15,9	18,3	22,4
m ³⁾	min.	4,7	5,7	7,6	9,6	11,6	13,3	15,3	18,9
m' ⁴⁾	min.	2,2	3,1	4,5	5,5	6,7	7,8	9	11,1
s	max.	8	10	13	15	18	21	24	30
	min.	7,78	9,78	12,73	14,73	17,73	20,67	23,67	29,16
r ⁵⁾	max.	0,3	0,36	0,48	0,6	0,72	0,88	0,96	1,2

- 1) The size in brackets should be avoided if possible.
- 2) P = pitch of the thread.
- 3) Also minimum thread height.
- 4) Minimum wrenching height (m' min. = T_a max. — see annex).
- 5) Radius applies both at the corner and the flats of the hexagon.

4 Specifications and reference International Standards

Nut	Types	NF (normal friction) and LF (low friction)
	International Standard	ISO 2320
Material		Steel, in accordance with ISO 898/2 and ISO 2320
Thread	Tolerance	6H
	International Standards	ISO 261, ISO 965
Mechanical properties	Property class	8, 9, 10, 12 (< M16)
	International Standards	ISO 898/2, ISO 2320
Torque and other requirements¹⁾	International Standard	ISO 2320
Tolerances	Product grade	A
	International Standard	ISO 4759/1
Finish		As processed Requirements for electroplated coatings are covered in ISO 4042. If different electroplating requirements are desired or if requirements are needed for other finishes, they should be negotiated between customer and supplier.
Acceptability		For acceptance procedure, see ISO 3269.

1) Lubrication is permitted to meet the requirements in ISO 2320.

iTeh STANDARD PREVIEW
(standards.iteh.ai)

5 Designation

Example for the designation of a prevailing torque type hexagon nut with flange and thread size $d = M12$, property class 8 and normal friction (NF) type:

ISO 7044:1983
Prevailing torque type hexagon nut with flange ISO 7044 : M12 - 8 - NF
1ccc3a52cc93/iso-7044-1983

Annex

Gauging of hexagon nut and flange

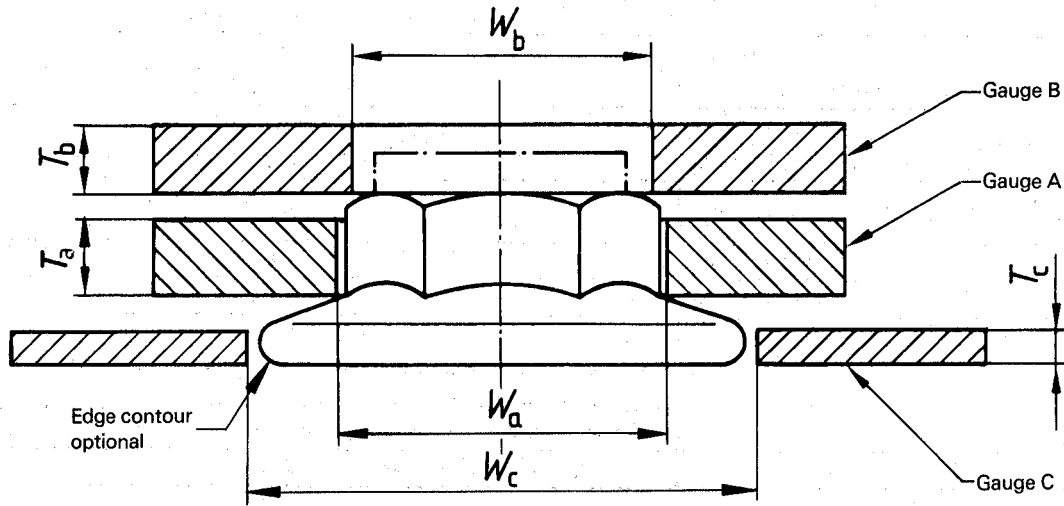

A.1 Recommended method for gauging of hex nut

The nut shall be gauged using two plain ring gauges, A and B, to demonstrate the coincidental acceptability of hex height, wrenching height, corner fill and width across corners. Gauge A shall be placed over the nut and shall seat on the flange. Gauge B shall be placed on the top of the nut normal to the nut axis. The two gauges shall not be in contact.

NOTE — Minimum inside diameter of gauge A equals maximum width across corners; maximum inside diameter of gauge B equals minimum width across corners minus 0,01 mm; maximum thickness of gauge A equals minimum wrenching height.

A.2 Recommended method for gauging of flange thickness

Gauge C is a flat feeler or ring gauge. It is used to prove that the flange thickness at the junction of the gauge with the hex portion is equal to or greater than specified values. The acceptance criterion is that gauge C will fit under gauge A without contact when the nut is seated on a flat plate or washer.

Dimensions in millimetres

Thread size	Gauge A				Gauge B			Gauge C		
	Inside diameter		Thickness		Inside diameter		Thickness	Inside diameter	Thickness	
	W_a max.	min.	max.	min.	max.	min.	T_b min.	W_c min.	max.	min.
M 5	9,25	9,24	2,2	2,19	8,78	8,77	3	14	1,08	1,07
M 6	11,56	11,55	3,1	3,09	11,04	11,03	4	16	1,19	1,18
M 8	15,02	15,01	4,5	4,49	14,37	14,36	4	20	1,31	1,30
M 10	17,33	17,32	5,5	5,49	16,63	16,62	5	24	1,81	1,80
M 12	20,79	20,78	6,7	6,69	20,02	20,01	5	29	2,20	2,19
M 14	24,26	24,25	7,8	7,79	23,35	23,34	6	32,5	2,55	2,54
M 16	27,72	27,71	9	8,99	26,74	26,73	6	37	2,96	2,95
M 20	34,65	34,64	11,1	11,09	32,94	32,93	6	45	3,70	3,69