

---

# International Standard



# 7045

---

INTERNATIONAL ORGANIZATION FOR STANDARDIZATION • МЕЖДУНАРОДНАЯ ОРГАНИЗАЦИЯ ПО СТАНДАРТИЗАЦИИ • ORGANISATION INTERNATIONALE DE NORMALISATION

---

## Cross recessed pan head screws — Product grade A

*Vis à métaux à tête cylindrique bombée large à empreinte cruciforme — Grade A*

First edition — 1983-07-15

**iTeh STANDARD PREVIEW**  
**(standards.iteh.ai)**

[ISO 7045:1983](https://standards.iteh.ai/catalog/standards/sist/7659d1b7-3ad1-4faa-a058-f02d71b85d09/iso-7045-1983)

<https://standards.iteh.ai/catalog/standards/sist/7659d1b7-3ad1-4faa-a058-f02d71b85d09/iso-7045-1983>

---

UDC 621.882.216.5

Ref. No. ISO 7045-1983 (E)

Descriptors : fasteners, bolts, screws, dimensions, designation.

Price based on 4 pages

## Foreword

ISO (the International Organization for Standardization) is a worldwide federation of national standards bodies (ISO member bodies). The work of developing International Standards is carried out through ISO technical committees. Every member body interested in a subject for which a technical committee has been authorized has the right to be represented on that committee. International organizations, governmental and non-governmental, in liaison with ISO, also take part in the work.

Draft International Standards adopted by the technical committees are circulated to the member bodies for approval before their acceptance as International Standards by the ISO Council.

International Standard ISO 7045 was developed by Technical Committee ISO/TC 2, *Fasteners*, and was circulated to the member bodies in December 1981.

It has been approved by the member bodies of the following countries:

Australia	Hungary	Poland
Austria	India	Romania
Belgium	Ireland	South Africa, Rep. of
Canada	Italy	Spain
China	Japan	Sri Lanka
Czechoslovakia	Korea, Dem. P. Rep. of	Sweden
Denmark	Korea, Rep. of	Switzerland
Egypt, Arab Rep. of	Mexico	USA
Finland	Netherlands	USSR
France	New Zealand	
Germany, F.R.	Norway	

The member bodies of the following countries expressed disapproval of the document on technical grounds:

Brazil  
United Kingdom

# Cross recessed pan head screws — Product grade A

iTeh STANDARD PREVIEW  
(standards.iteh.ai)

## 1 Scope and field of application

This International Standard specifies the characteristics of cross recessed pan head screws with thread sizes from M 1,6 to M 10 inclusive.

If other specifications are required, it is recommended that they should be selected from existing International Standards, for example ISO 261, ISO 888, ISO 898, ISO 965, ISO 3506.

## 2 References

ISO 225, *Fasteners — Bolts, screws, studs and nuts — Symbols and designations of dimensions.*

ISO 261, *ISO general purpose metric screw threads — General plan.*

ISO 888, *Bolts, screws and studs — Nominal lengths, and thread lengths for general purpose bolts.*

ISO 898, *Mechanical properties of fasteners.*

ISO 965, *ISO general purpose metric screw threads — Tolerances.*

ISO 3269, *Fasteners — Acceptance inspection.*<sup>1)</sup>

ISO 3506, *Corrosion-resistant stainless steel fasteners — Specifications.*

ISO 4042, *Threaded components — Electroplated coatings components.*<sup>1)</sup>

ISO 4757, *Cross recesses for screws.*

ISO 4759/1, *Tolerances for fasteners — Part 1: Bolts, screws and nuts with thread diameters > 1,6 and < 150 mm and product grades A, B and C.*

ISO 7721, *Countersunk head screws — Head configuration and gauging.*

1) At present at the stage of draft.

3 Dimensions

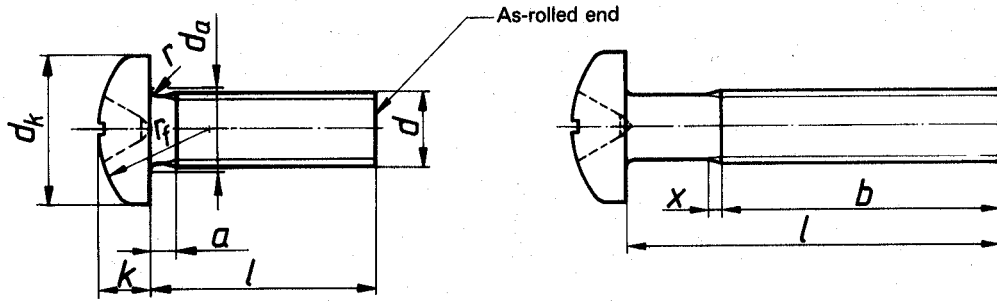

Recess

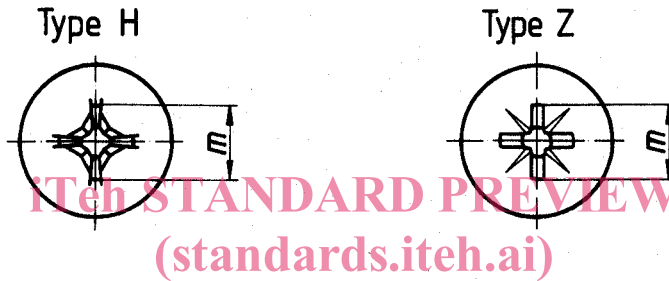

ITeH STANDARD PREVIEW  
(standards.iteh.ai)

Shank diameter is approximately equal to pitch diameter or equal to major diameter permissible

ISO 7045:1983

<https://standards.iteh.ai/catalog/standards/sist/7659d1b7-3ad1-4faa-a058-f02d71b85d09/iso-7045-1983>

Dimensions in millimetres

Thread size <i>d</i>	M 1,6	M 2	M 2,5	M 3	(M 3,5) <sup>1)</sup>	M 4	M 5	M 6	M 8	M 10		
<i>p</i> <sup>2)</sup>	0,35	0,4	0,45	0,5	0,6	0,7	0,8	1	1,25	1,5		
<i>a</i> max.	0,7	0,8	0,9	1	1,2	1,4	1,6	2	2,5	3		
<i>b</i> min.	25	25	25	25	38	38	38	38	38	38		
<i>d<sub>a</sub></i> max.	2,1	2,6	3,1	3,6	4,1	4,7	5,7	6,8	9,2	11,2		
<i>d<sub>k</sub></i>	max.	3,2	4	5	5,6	7	8	9,5	12	16		
	min.	2,9	3,7	4,7	5,3	6,64	7,64	9,14	11,57	15,57		
<i>k</i> <sup>3)</sup>	max.	1,3	1,6	2,1	2,4	2,6	3,1	3,7	4,6	6		
	min.	1,16	1,46	1,96	2,26	2,46	2,92	3,52	4,30	5,70		
<i>r</i> min.	0,1	0,1	0,1	0,1	0,1	0,2	0,2	0,25	0,4	0,4		
<i>r<sub>f</sub></i> ≈	2,5	3,2	4	5	6	6,5	8	10	13	16		
<i>x</i> max.	0,9	1	1,1	1,25	1,5	1,75	2	2,5	3,2	3,8		
Cross recess	Recess No.	0		1		2		3		4		
	Type H Penetration	<i>m</i> ref.	1,7	1,9	2,7	3	3,9	4,4	4,9	6,9	9	10,1
		min.	0,7	0,9	1,15	1,4	1,4	1,9	2,4	3,1	4	5,2
		max.	0,95	1,2	1,55	1,8	1,9	2,4	2,9	3,6	4,6	5,8
	Type Z Penetration	<i>m</i> ref.	1,7	1,9	2,6	2,9	3,9	4,4	4,6	6,8	8,8	10
		min.	0,65	0,85	1,1	1,35	1,45	1,9	2,3	3,05	4,05	5,25
		max.	0,9	1,2	1,5	1,75	1,9	2,35	2,75	3,5	4,5	5,7
	nom.	(1), (3), 4)	min.	max.								
3		2,8	3,2									
4	3,7	4,3										
5	4,7	5,3										
6	5,7	6,3										
8	7,7	8,3										
10	9,7	10,3										
12	11,6	12,4										
(14)	13,6	14,4										
16	15,6	16,4										
20	19,6	20,4										
25	24,6	25,4										
30	29,6	30,4										
35	34,5	35,5										
40	39,5	40,5										
45	44,5	45,5										
50	49,5	50,5										
(55)	54	56										
60	59	61										

- 1) Sizes in brackets should be avoided if possible.
- 2) *P* = pitch of the thread.
- 3) Min. and max. values according to ISO 4759/1, but rounded to one decimal place.
- 4) Screws with nominal lengths above the stepped line, marked thus — — —, are threaded up to the head ( $b = l - a$ ).

**4 Specifications and reference International Standards**

Material		Steel	Stainless steel	Non-ferrous metal
Thread	Tolerance	6g		
	International Standards	ISO 261, ISO 965		
Mechanical properties	Property class	4.8 <sup>1)</sup>	A2 - 70, A2 - 50	2)
	International Standards	ISO 898/1	ISO 3506	
Tolerances	Product grade	A		
	International Standard	ISO 4759/1		
Cross recesses		ISO 4757		
Finish		Plain		
		Requirements for electroplating are covered in ISO 4042. If different electroplating requirements are desired or if requirements are needed for other finishes, they should be negotiated between supplier and customer.		
Acceptability		The acceptance procedure is covered in ISO 3269.		

- 1) Max. hardness 255 HV permissible.
- 2) Will be covered in a future International Standard.

**5 Designation**

Example for the designation of a cross recessed pan head screw, with thread size  $d = M5$ , nominal length  $l = 20$  mm, property class 4.8 and cross recess type Z:

**Pan head screw ISO 7045 - M5 × 12 - 4.8 - Z**

<https://standards.iteh.ai/catalog/standards/sist/7659d1b7-3ad1-4faa-a058-f02d71b85d09/iso-7045-1983>  
 (standards.iteh.ai)